

2007 Hummer H3

2007 TRANSMISSION Transfer Case - BW 4493/4494 - H3

2007 TRANSMISSION

Transfer Case - BW 4493/4494 - H3

SPECIFICATIONS

APPROXIMATE FLUID CAPACITIES

Approximate Fluid Capacities

Application	Specification	
	Metric	English
Manual Transmission Fluid GM P/N 88861800 (Canadian P/N 88861801)	1.5 liters	1.6 quarts

FASTENER TIGHTENING SPECIFICATIONS

Fastener Tightening Specifications

Application	Specification	
	Metric	English
Adapter Studs	14 N.m	10 lb ft
Case Bolts	25 N.m	18 lb ft
Drain Plug	16 N.m	12 lb ft
Encoder Motor Bolts	10 N.m	89 lb in
Encoder Motor Bracket Bolt	10 N.m	89 lb in
Encoder Motor Support Bracket Nuts	5 N.m	44 lb in
Fill Plug	16 N.m	12 lb ft
Front Drive Shaft Universal Joint Clamp Bolts	20 N.m	15 lb ft
Front Output Shaft Flange Nut	319 N.m	235 lb ft
Transfer Case Shield Bolts	30 N.m	23 lb ft
Transfer Case to Transmission Nuts	50 N.m	37 lb ft
Transmission Crossmember to Frame Bracket - Horizontal - Bolts and Nuts	50 N.m	37 lb ft
Transmission Crossmember to Frame - Vertical - Bolts	100 N.m	74 lb ft
Transmission Mount to Support Nuts	57 N.m	42 lb ft
Vehicle Speed Sensor	17 N.m	13 lb ft
Vent	6 N.m	53 lb in

2007 Hummer H3

2007 TRANSMISSION Transfer Case - BW 4493/4494 - H3

SEALERS, ADHESIVES AND LUBRICANTS

Sealers, Adhesives and Lubricants

Application	Type of Material	GM Part Number	
		United States	Canada
Drain Plug	Pipe Sealant	12346004	10953480
Fill Plug	Pipe Sealant	12346004	10953480
Rear Case Half to Front Case Half	RTV Sealant	12345739	10953541
Transfer Case Fluid	Manual Transmission Fluid	88861800	88861801
Vehicle Speed Sensor O-Ring	Manual Transmission Fluid	88861800	88861801
Vent	Pipe Sealant	12346004	10953480

SCHEMATIC AND ROUTING DIAGRAMS

TRANSFER CASE CONTROL SCHEMATICS

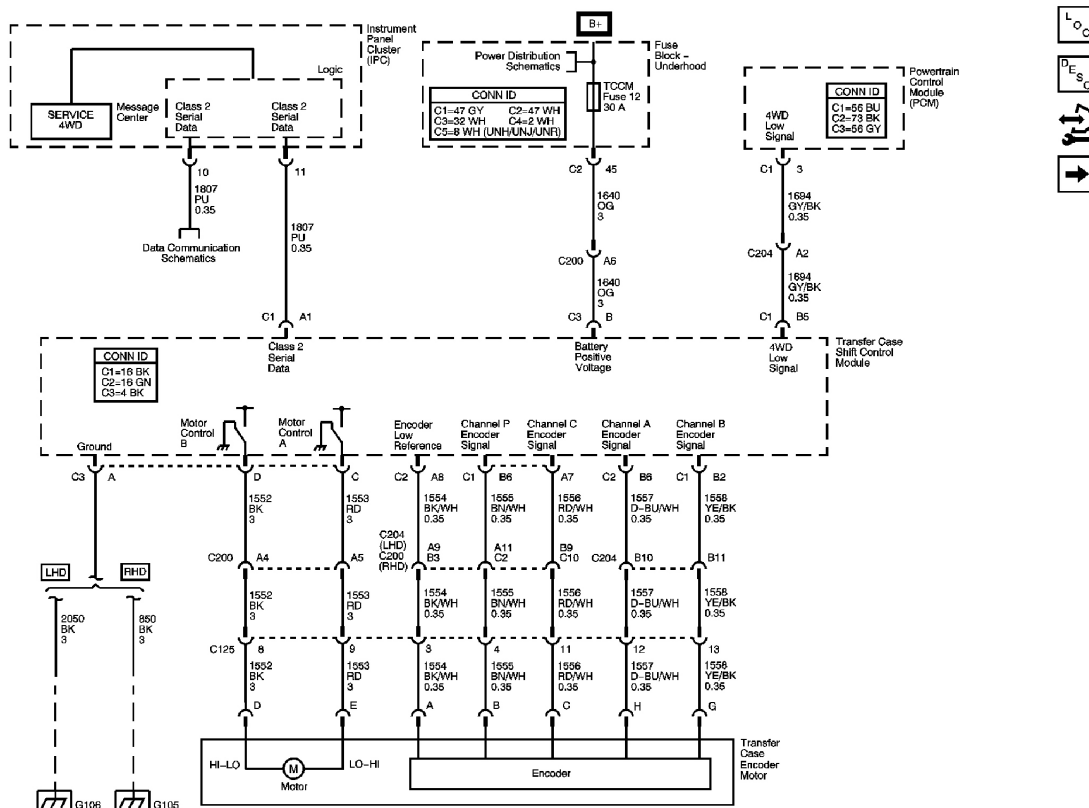

Fig. 1: Power, Ground, Serial Data, Indicator, VSS & Encoder Motor Schematic
 Courtesy of GENERAL MOTORS CORP.

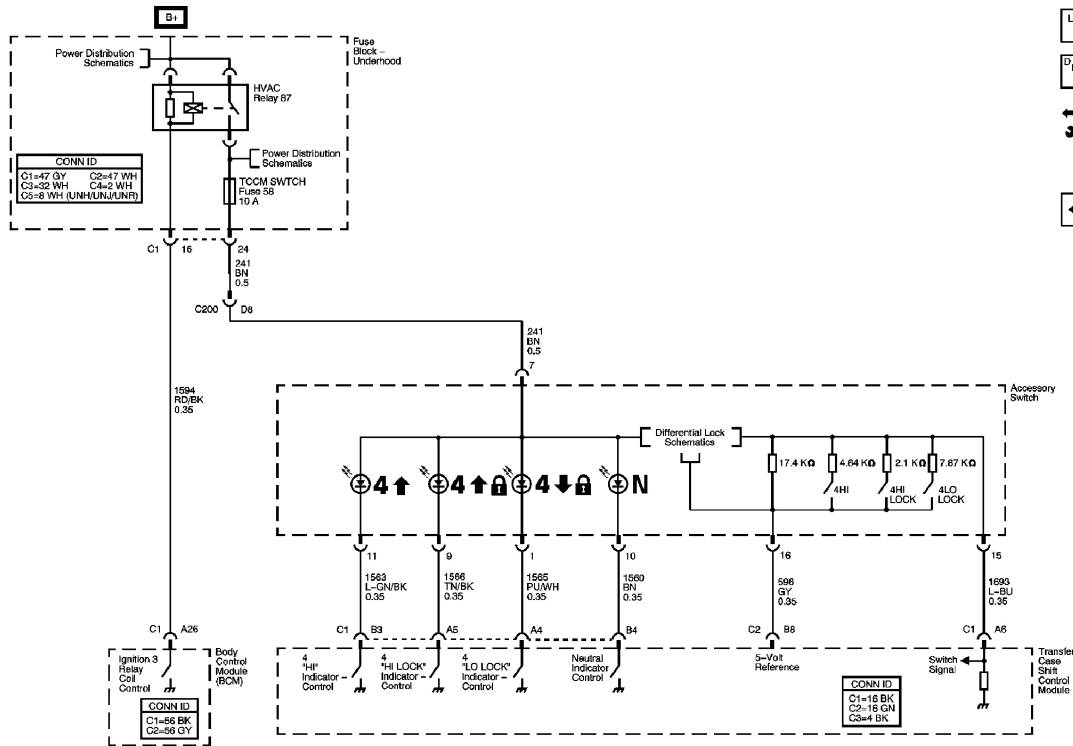

Fig. 2: Shift Control Switch Inputs Schematic
 Courtesy of GENERAL MOTORS CORP.

COMPONENT LOCATOR

TRANSFER CASE CONTROL COMPONENT VIEWS

2007 Hummer H3

2007 TRANSMISSION Transfer Case - BW 4493/4494 - H3

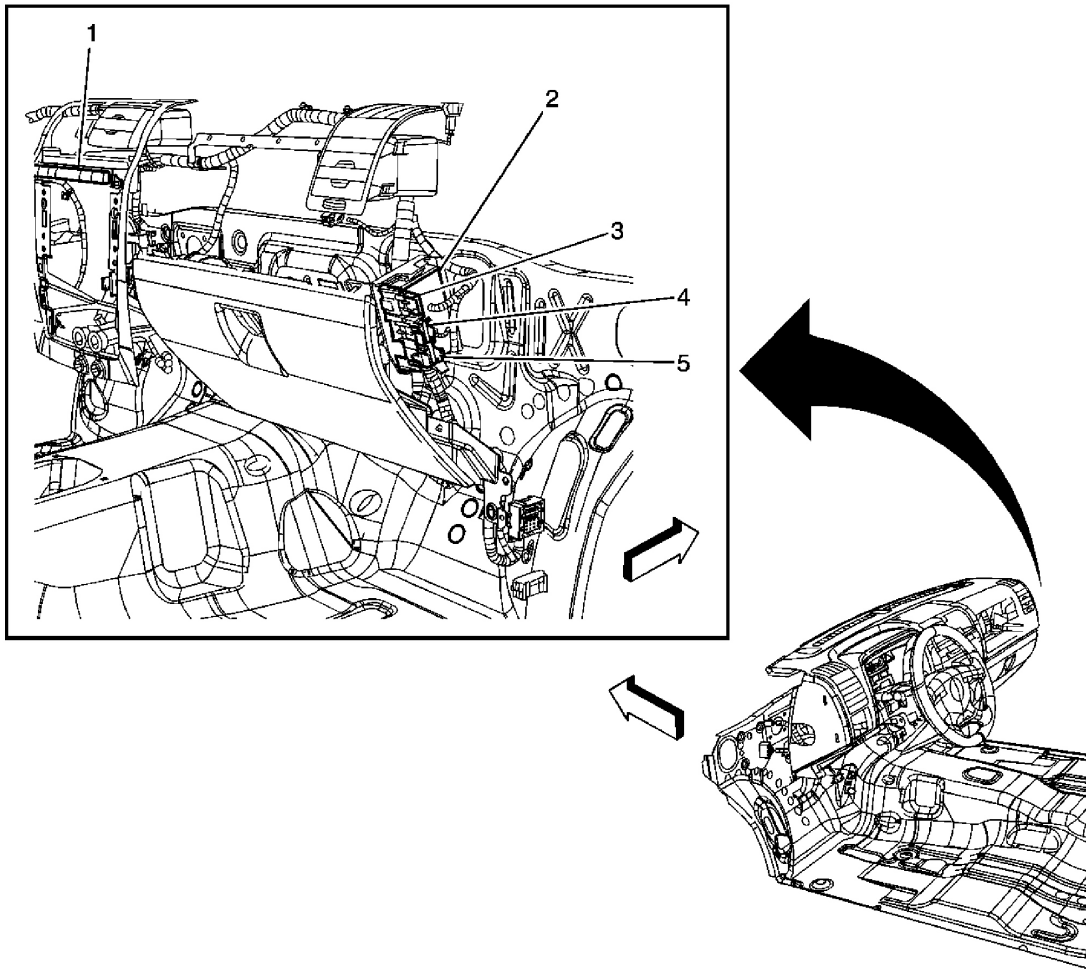

Fig. 3: Transfer Case Control Components - Right Side Of I/P
Courtesy of GENERAL MOTORS CORP.

Callouts For Fig. 3

Callout	Component Name
1	Accessory Switch
2	Transfer Case Shift Control Module
3	Transfer Case Shift Control Module C3
4	Transfer Case Shift Control Module C2
5	Transfer Case Shift Control Module C1

2007 Hummer H3

2007 TRANSMISSION Transfer Case - BW 4493/4494 - H3

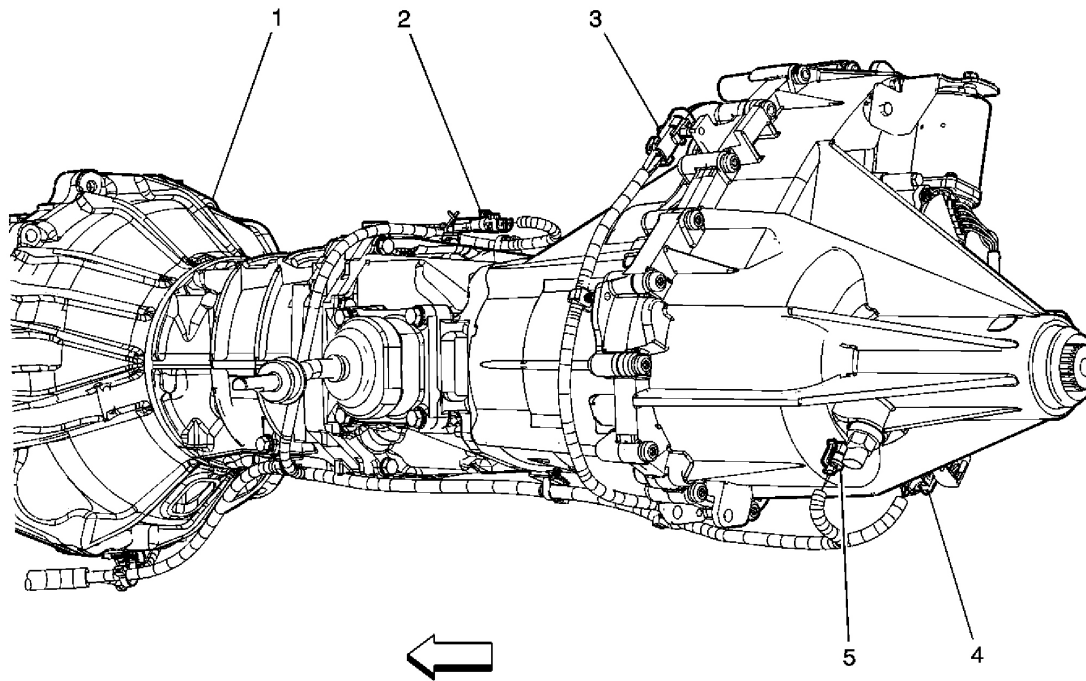

Fig. 4: Identifying Rear Engine Harness (MA5)
Courtesy of GENERAL MOTORS CORP.

Callouts For Fig. 4

Callout	Component Name
1	Transmission Case
2	Backup Lamp Switch
3	Heated Oxygen Sensor (HO2S) 2
4	Transfer Case Encoder Motor Connector
5	Vehicle Speed Sensor (VSS) Connector

2007 Hummer H3

2007 TRANSMISSION Transfer Case - BW 4493/4494 - H3

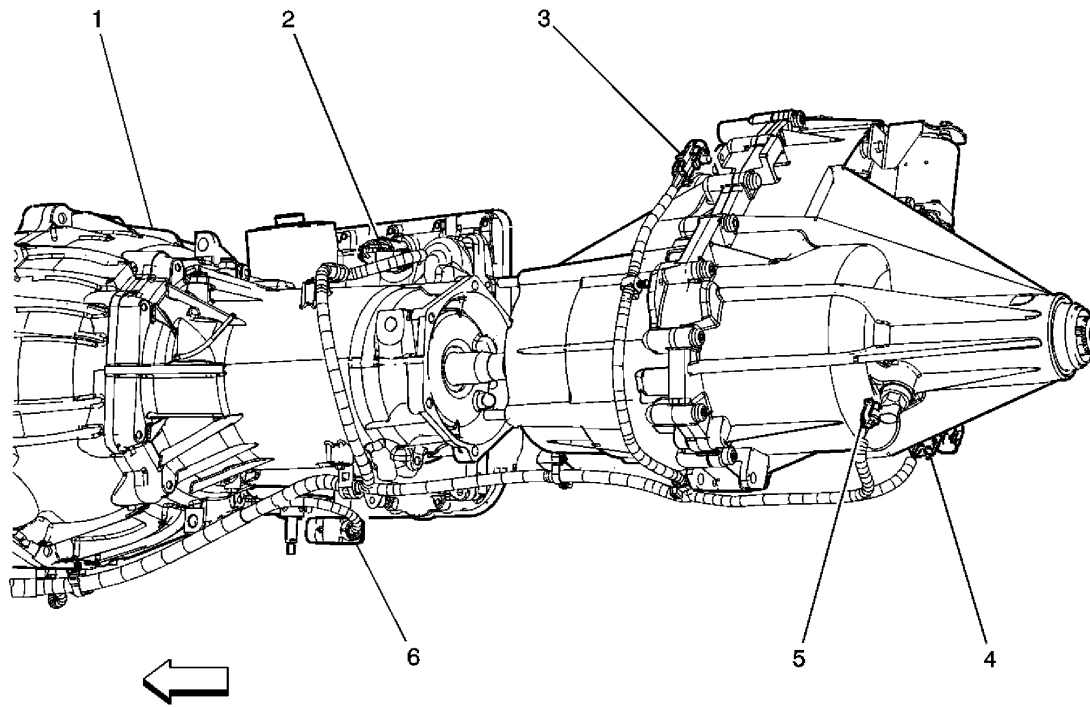

Fig. 5: Identifying Rear Engine Harness (M30)

Courtesy of GENERAL MOTORS CORP.

Callouts For Fig. 5

Callout	Component Name
1	Transmission Case
2	C175 Engine Harness to Transmission Internal Harness
3	Heated Oxygen Sensor (HO2S) 2
4	Transfer Case Encoder Motor Connector
5	Vehicle Speed Sensor (VSS) Connector
6	Park/Neutral Position (PNP) Switch

TRANSFER CASE CONTROL CONNECTOR END VIEWS

Transfer Case Encoder Motor

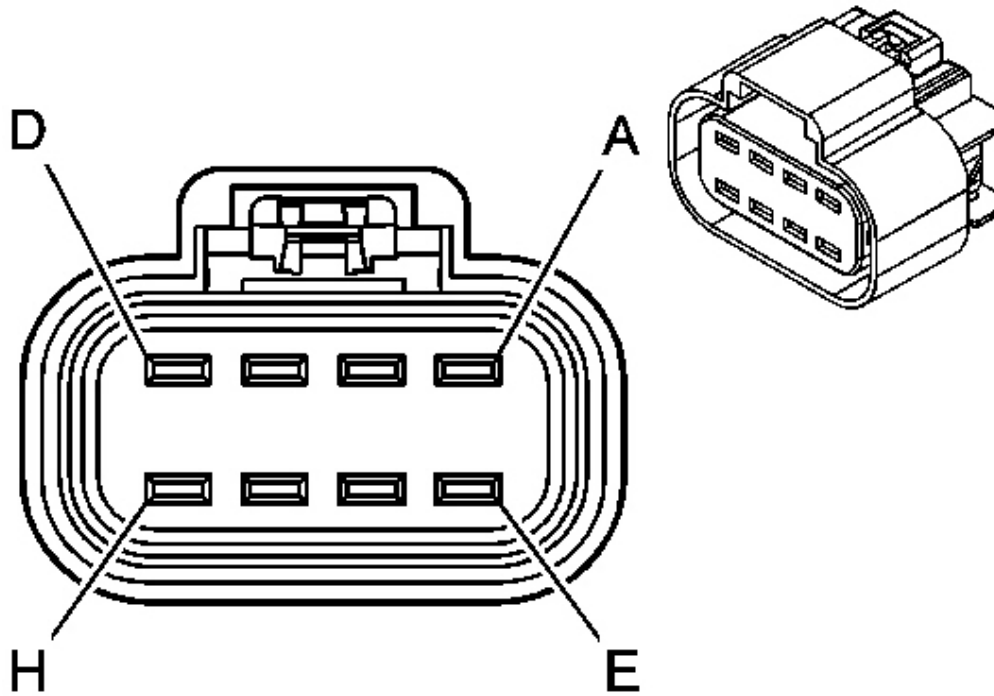

Fig. 6: Transfer Case Encoder Motor Connector End View
Courtesy of GENERAL MOTORS CORP.

Transfer Case Encoder Motor Connector Parts Information

Connector Part Information

- OEM: 15326654
- Service: 88986254
- Description: 8-Way F GT 280 Series Sealed (BK)

Terminal Part Information

- Pins: A-C, G-H
- Terminal/Tray: 15304719/19
- Core/Insulation Crimp: E/5
- Release Tool/Test Probe: 15315247/J-35616-4A (PU)

2007 Hummer H3

2007 TRANSMISSION Transfer Case - BW 4493/4494 - H3

- Pins: D-E
- Terminal/Tray: 15304720/19
- Core/Insulation Crimp: 4/5
- Release Tool/Test Probe: 15315247/J-35616-4A (PU)

Transfer Case Encoder Motor Connector Terminal Identification

Pin	Wire Color	Circuit No.	Function
A	BK/WH	1554	Encoder Low Reference
B	BN/WH	1555	Channel P Encoder Signal
C	RD/WH	1556	Channel C Encoder Signal
D	BK	1552	Motor Control B
E	RD	1553	Motor Control A
F	-	-	Not Used
G	YE/BK	1558	Channel B Encoder Signal
H	D-BU/WH	1557	Channel A Encoder Signal

Transfer Case Shift Control Module C1

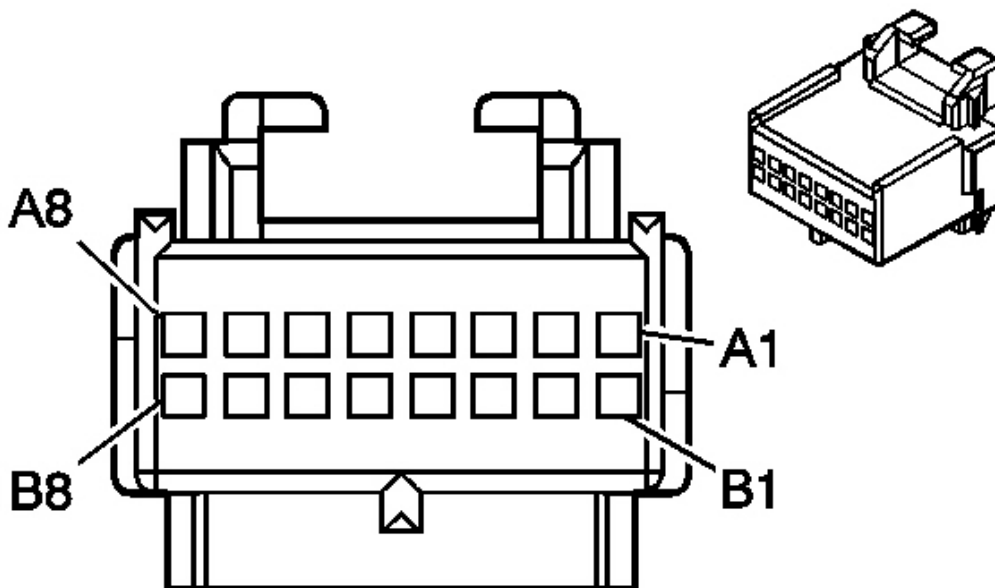

Fig. 7: Transfer Case Shift Control Module C1 Connector End View
 Courtesy of GENERAL MOTORS CORP.

Transfer Case Shift Control Module C1 Connector Parts Information

Connector Part Information

- OEM: 12084944
- Service: 12084944
- Description: 16-Way F Micro-Pack 100 Series (BK)

Terminal Part Information

- Pins: A1, A3-B6
- Terminal/Tray: 12146447/3
- Core/Insulation Crimp: E/C
- Release Tool/Test Probe: 12031876-1/J-35616-6 (BN)

- Pins: A2, B8
- Terminal/Tray: 12146448/19
- Core/Insulation Crimp: E/A
- Release Tool/Test Probe: 12031876-1/J-35616-6 (BN)

Transfer Case Shift Control Module C1 Connector Terminal Identification

Pin	Wire Color	Circuit No.	Function
A1	PU	1807	Class 2 Serial Data
A2	L-GN	2659	Rear Differential Lock High Control
A3	PK	1561	Differential Lock Indicator Control
A4	PU/WH	1565	4 LO LOCK Indicator Control
A5	TN/BK	1566	4 HI LOCK Indicator Control
A6	L-BU	1693	Switch Signal
A7	RD/WH	1556	Channel C Encoder Signal
A8	-	-	Not Used
B1	-	-	Not Used
B2	YE/BK	1558	Channel B Encoder Signal
B3	L-GN/BK	1563	4 HI Indicator Control
B4	BN	1560	Neutral Indicator Control
B5	GY/BK	1694	4WD Low Signal

2007 Hummer H3

2007 TRANSMISSION Transfer Case - BW 4493/4494 - H3

B6	BN/WH	1555	Channel P Encoder Signal
B7	-	-	Not Used
B8	BK	1725	Rear Differential Lock Low Reference

Transfer Case Shift Control Module C2

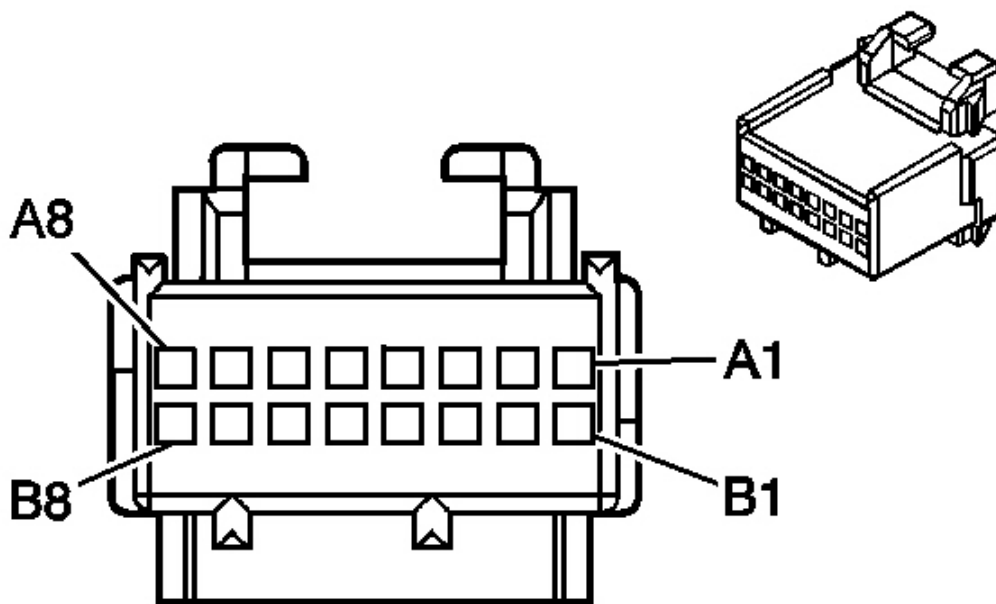

Fig. 8: Transfer Case Shift Control Module C2 Connector End View
Courtesy of GENERAL MOTORS CORP.

Transfer Case Shift Control Module C2 Connector Parts Information

Connector Part Information

- OEM: 12110259
- Service: 12110259
- Description: 16-Way F Micro-Pack 100 Series (GN)

Terminal Part Information

- Terminal/Tray: 12146447/3

2007 Hummer H3

2007 TRANSMISSION Transfer Case - BW 4493/4494 - H3

- Core/Insulation Crimp: E/C
- Release Tool/Test Probe: 12031876-1/J-35616-6 (BN)

Transfer Case Shift Control Module C2 Connector Terminal Identification

Pin	Wire Color	Circuit No.	Function
A1-A7	-	-	Not Used
A8	BK/WH	1554	Encoder Low Reference
B1-B5	-	-	Not Used
B6	D-BU/WH	1557	Channel A Encoder Signal
B7	-	-	Not Used
B8	GY	596	5-Volt Reference

Transfer Case Shift Control Module C3

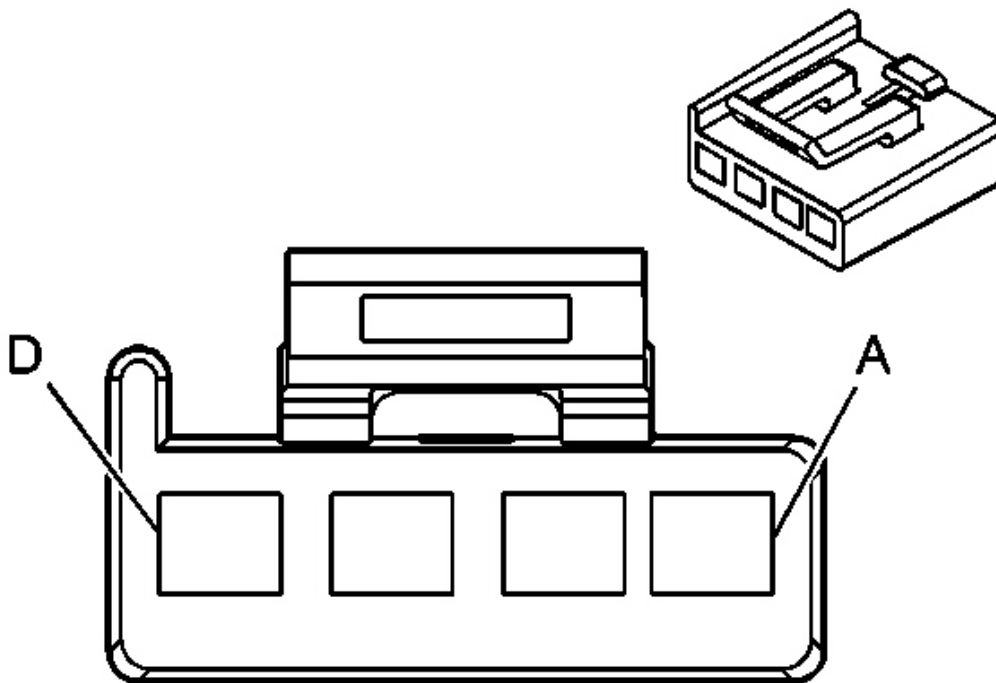

Fig. 9: Transfer Case Shift Control Module C3 Connector End View
Courtesy of GENERAL MOTORS CORP.

2007 Hummer H3

2007 TRANSMISSION Transfer Case - BW 4493/4494 - H3

Transfer Case Shift Control Module C3 Connector Parts Information

Connector Part Information

- OEM: 12052856
- Service: 12125636
- Description: 4-Way F Metri-Pack 280 Series (BK)

Terminal Part Information

- Terminal/Tray: 12015858/4
- Core/Insulation Crimp: F/G
- Release Tool/Test Probe: 12094430/J-35616-4A (PU)

Transfer Case Shift Control Module C3 Connector Terminal Identification

Pin	Wire Color	Circuit No.	Function
A	BK	2050	Ground
B	OG	1640	Battery Positive Voltage
C	RD	1553	Motor Control A
D	BK	1552	Motor Control B

TRANSFER CASE DISASSEMBLED VIEW

2007 Hummer H3

2007 TRANSMISSION Transfer Case - BW 4493/4494 - H3

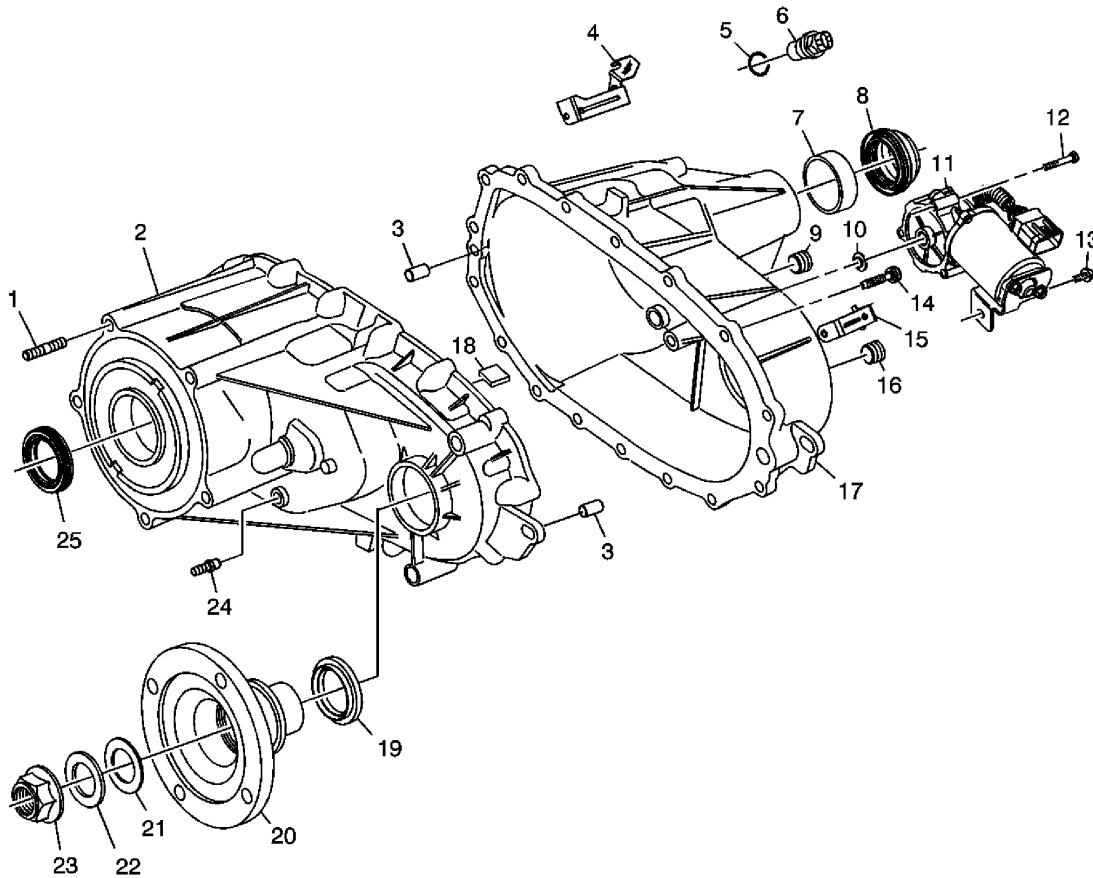

Fig. 10: Transfer Case Disassembled View - Case
 Courtesy of GENERAL MOTORS CORP.

Callouts For Fig. 10

Callout	Component Name
1	Adapter Stud
2	Front Case Half
3	Location Pin
3	Location Pin
4	Fuel Line Bracket
5	Vehicle Speed Sensor O-Ring Seal
6	Vehicle Speed Sensor
7	Output Shaft Bushing
8	Rear Output Shaft Seal
9	Fill Plug
10	Shift Shaft Seal

2007 Hummer H3

2007 TRANSMISSION Transfer Case - BW 4493/4494 - H3

11	Encoder Motor
12	Encoder Motor Bolt
13	Encoder Motor Bracket Bolt
14	Case Half Bolt
15	Wiring Harness Bracket
16	Drain Plug
17	Rear Case Half
18	Magnet
19	Front Output Shaft Seal
20	Front Output Shaft Flange
21	Front Output Shaft Flange Seal
22	Front Output Shaft Flange Washer
23	Front Output Shaft Flange Nut
24	Vent
25	Input Shaft Seal

2007 Hummer H3

2007 TRANSMISSION Transfer Case - BW 4493/4494 - H3

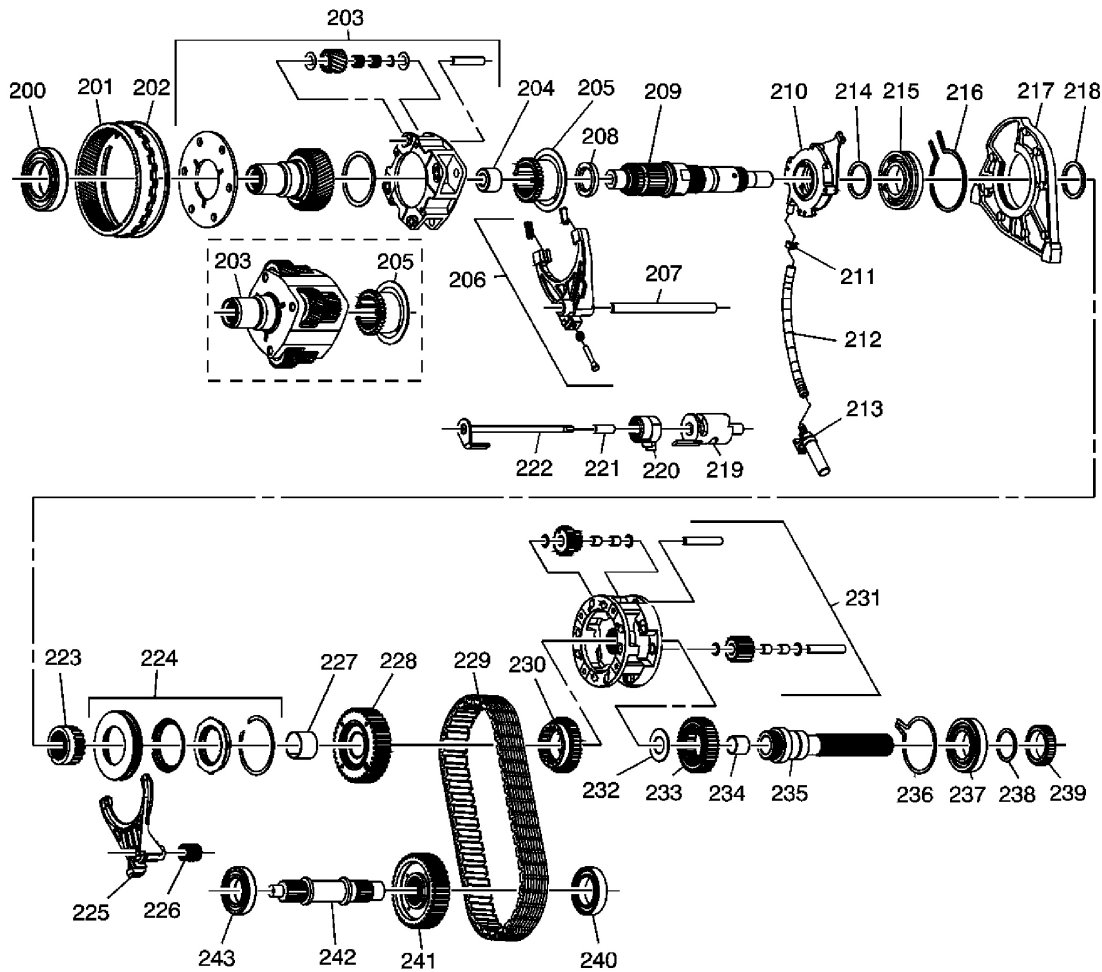

Fig. 11: Transfer Case Disassembled View - Internal Components
 Courtesy of GENERAL MOTORS CORP.

Callouts For Fig. 11

Callout	Component Name
200	Input Gear Bearing
201	Ring Gear
202	Ring Gear Retaining Ring
203	High/Low Planetary Carrier Assembly
203	High/Low Planetary Carrier Assembly
204	Mainshaft Front Support Bearing
205	High/Low Range Sleeve
205	High/Low Range Sleeve
206	High/Low Range Shift Fork Assembly

2007 Hummer H3

2007 TRANSMISSION Transfer Case - BW 4493/4494 - H3

207	Shift Fork Shaft
208	Input Gear Thrust Bearing
209	Mainshaft
210	Oil Pump
211	Oil Pump Hose Clamp
212	Oil Pump Hose
213	Oil Pump Screen
214	Upper Center Bearing Support Thrust Washer
215	Bearing
216	Snap Ring
217	Center Bearing Support
218	Lower Center Support Bearing Thrust Washer
219	Shift Cam
220	Shift Shaft Torsional Spring
221	Shift Shaft Spacer
222	Shift Shaft
223	Inner Lockup Hub
224	Lockup Mode Shift Collar Assembly
225	Lockup Mode Shift Fork
226	Shift Fork Shaft Spring
227	Drive Sprocket Bushing
228	Drive Sprocket
229	Drive Chain
230	Front Output Sun Gear
231	Planetary Differential Assembly
232	Rear Output Shaft Thrust Washer
233	Rear Output Sun Gear
234	Mainshaft Rear Support Bushing
235	Rear Output Shaft
236	Rear Output Shaft Bearing Outer Retaining Ring
237	Rear Output Shaft Bearing
238	Rear Output Shaft Bearing Retaining Ring
239	Speed Sensor Tone Wheel
240	Front Output Shaft Rear Bearing
241	Driven Gear

2007 Hummer H3

2007 TRANSMISSION Transfer Case - BW 4493/4494 - H3

	Front Output Shaft
243	Front Output Shaft Front Bearing

DIAGNOSTIC INFORMATION AND PROCEDURES

DIAGNOSTIC CODE INDEX

DIAGNOSTIC CODE INDEX

DTC	Description
<u>DTC B0790</u>	Transfer Case Neutral Indicator Circuit Malfunction
<u>DTC B2725</u>	ATC Mode Switch Circuit Malfunction
<u>DTC C0306</u>	Motor A or B Circuit Malfunction
<u>DTC C0327</u>	Encoder Circuit Malfunction
<u>DTC C0329</u>	Encoder Signal Circuit Low
<u>DTC C0359</u>	Four Wheel Drive Low Range (4WD low) Discrete Output Circuit Malfunction
<u>DTC C0550</u>	ECU Malfunction

DIAGNOSTIC STARTING POINT - TRANSFER CASE

Begin the system diagnosis with the **Diagnostic System Check - Vehicle** . The Diagnostic System Check will provide the following information:

- The identification of the control module or modules that command the system.
- The ability of the control module or modules to communicate through the serial data circuit.
- The identification of any stored diagnostic trouble codes (DTCs) and the status of the codes.

The use of the **Diagnostic System Check - Vehicle** will identify the correct procedure for diagnosing the system and where the procedure is located.

SCAN TOOL OUTPUT CONTROLS

Scan Tool Output Controls

Scan Tool Output Control	Additional Menu Selections	Description
Refer to the scan tool manual for complete scan tool operating instructions.		
4WD High Indicator Light	-	This function allows the technician to command the 4WD high indicator light, within the transfer case

2007 Hummer H3

2007 TRANSMISSION Transfer Case - BW 4493/4494 - H3

		shift control switch, on or off.
4WD High Lock Indicator Light	-	This function allows the technician to command the 4WD high lock indicator light, within the transfer case shift control switch, on or off.
4WD Low Lock Indicator Light	-	This function allows the technician to command the 4WD low lock indicator light, within the transfer case shift control switch, on or off.
Differential Lock Indicator Light	-	This function allows the technician to command the differential indicator light, within the transfer case shift control switch, on or off.
Motor A Driver - High	-	This function allows the technician to request the high side driver for the motor control A circuit, thus allowing the technician to test the circuit and the transfer case shift control module for their ability to provide battery voltage to the motor.
Motor A Driver - Low	-	This function allows the technician to request the low side driver for the motor control A circuit, thus allowing the technician to test the circuit and the transfer case shift control module for their ability to provide a ground path for the motor.
Motor B Driver - High	-	This function allows the technician to request the high side driver for the motor control B circuit, thus allowing the technician to test the circuit and the transfer case shift control module for their ability to provide battery voltage to the motor.
Motor B Driver - Low	-	This function allows the technician to request the low side driver for the motor control B circuit, thus allowing the technician to test the circuit and the transfer case shift control module for their ability to provide a ground path for the motor.
Neutral Indicator Light	-	This function allows the technician to command the neutral indicator light, within the transfer case shift control switch, on or off.

SCAN TOOL DATA LIST

Scan Tool Data List

Scan Tool Parameter	Data List	Units Displayed	Typical Data Value
---------------------	-----------	-----------------	--------------------

2007 Hummer H3

2007 TRANSMISSION Transfer Case - BW 4493/4494 - H3

Engine is at Idle, Upper Radiator Hose is Hot, Closed Throttle, Gear is in Park or Neutral and Accessories are OFF.

4WD High Indicator Light	Transfer Case Data	On/Off	Off
4WD High Lock Indicator Light	Transfer Case Data	On/Off	Off
4WD Low Active	Transfer Case Data	Yes/No	No
4WD Low Lock Indicator Light	Transfer Case Data	On/Off	Off
ATC Application	Transfer Case Data	Number	Number
Encoder Circuit A	Transfer Case Data	On/Off	On
Encoder Circuit B	Transfer Case Data	On/Off	On
Encoder Circuit C	Transfer Case Data	On/Off	On
Encoder Circuit P	Transfer Case Data	On/Off	On
Encoder Gear Position	Transfer Case Data	4WD High/4WD Low/AWD	4WD High
Encoder Supply Voltage	Transfer Case Data	Volts	2.55
Ign. Cycles Since Last Current DTC	Transfer Case Data	Count	Varies
Mode Switch Return Voltage	Transfer Case Data	Volts	0-5 V
Mode Switch Selected	Transfer Case Data	Transfer Case Mode	Inactive
Motor A High Side Driver Status	Transfer Case Data	On/Off	NO
Motor A Low Side Driver Status	Transfer Case Data	On/Off	NO
Motor B High Side Driver Status	Transfer Case Data	On/Off	NO
Motor B Low Side Driver Status	Transfer Case	On/Off	NO

2007 Hummer H3

2007 TRANSMISSION Transfer Case - BW 4493/4494 - H3

	Data		
Neutral Indicator Light	Transfer Case Data	On/Off	Off
Rear Axle Lock	Transfer Case Data	On/Off	Off
Rear Axle Lock Indicator Lamp	Transfer Case Data	On/Off	Off
Rear Axle Lock Request	Transfer Case Data	On/Off	Off
Software ID	Transfer Case Data	Part Number	Part Number

SCAN TOOL DATA DEFINITIONS

4WD High Indicator Light

This parameter displays On when the transfer case shift control module commands the 4WD high indicator light On. The scan tool displays On or Off.

4WD High Lock Indicator Light

This parameter displays On when the transfer case shift control module commands the 4WD high lock indicator light On. The scan tool displays On or Off.

4WD Low Active

This parameter displays Yes when the transfer case is currently in the 4WD low lock mode. The scan tool displays Yes or No.

4WD Low Lock Indicator Light

This parameter displays On when the transfer case shift control module commands the 4WD low lock indicator light On. The scan tool displays On or Off.

ATC Application

This parameter displays the model number assigned to the transfer case. The scan tool displays a numeric value.

Encoder Circuits A, B, C and P

2007 Hummer H3

2007 TRANSMISSION Transfer Case - BW 4493/4494 - H3

This parameter displays Off if a high voltage is detected at the circuit. The parameter displays On if the encoder motor grounds the circuit and pulls the voltage low. The encoder circuits allow the transfer case shift control module to determine what position the transfer case is in.

Encoder Gear Position

This parameter displays the mode the transfer case is currently in.

Encoder Supply Voltage

This parameter displays the voltage supplied to the encoder motor. The scan tool displays a range of 0-25 volts.

GM Part Number

This parameter displays the GM part number assigned to the module package: module, software and calibrations. The scan tool displays a numeric value.

Ign. Cycles Since Last Current DTC

This parameter displays how many ignition cycles have occurred since last current DTC was set. The scan tool displays a numeric value.

Mode Switch Return Voltage

This parameter displays the return voltage from the transfer case shift control switch. The scan tool displays a range of 0-5 volts.

Mode Switch Selected

This parameter displays the transfer case shift control switch button currently depressed by the driver.

Motor A High Side Driver

This parameter displays On when battery voltage is applied to the Motor A Circuit. The scan tool displays On or Off.

Motor A Low Side Driver

This parameter displays On when ground is applied to the Motor A Circuit. The scan tool

displays On or Off.

Motor B High Side Driver

This parameter displays On when battery voltage is applied to the Motor B Circuit. The scan tool displays On or Off.

Motor B Low Side Driver

This parameter displays On when ground is applied to the Motor B Circuit. The scan tool displays On or Off.

Neutral Indicator Light

This parameter displays On when the transfer case shift control module commands the neutral indicator light On. The scan tool displays On or Off.

Rear Axle Lock

This parameter displays On when the transfer case shift control module commands the rear axle lock solenoid to be applied. The scan tool displays On or Off.

Rear Axle Lock Indicator Light

This parameter displays On when the transfer case shift control module requests the rear axle lock indicator On. The scan tool displays On or Off.

Rear Axle Lock Request

This parameter displays On when the transfer case shift control module receives a rear axle lock request from the transfer case shift control switch or a scan tool. The scan tool displays On or Off.

Software ID

This parameter displays a numeric value indicating which version of software is currently installed in the transfer case shift control module.

DIAGNOSTIC TROUBLE CODE (DTC) LIST

Diagnostic Trouble Code (DTC) List

--	--

2007 Hummer H3

2007 TRANSMISSION Transfer Case - BW 4493/4494 - H3

Description	Module
<u>DTC B0790</u>	FT4WD
<u>DTC B2725</u>	FT4WD
<u>DTC C0306</u>	FT4WD
<u>DTC C0327</u>	FT4WD
<u>DTC C0329</u>	FT4WD
<u>DTC C0359</u>	FT4WD
DTC C0388, refer to <u>DTC C0388</u>	FT4WD
<u>DTC C0550</u>	FT4WD

DTC B0790

Circuit Description

The Neutral indicator circuit consists of a ignition 3 voltage circuit and a Neutral indicator control circuit. When the Neutral mode has been selected by the driver, current is supplied to the Neutral indicator by the ignition 3 voltage circuit, traveling through the Neutral indicator LED at which time the transfer case shift control module supplies the ground through the Neutral indicator control circuit. This DTC indicates an open, short to ground or a short to voltage.

DTC Descriptor

This diagnostic procedure supports the following DTC:

DTC B0790 Transfer Case Neutral Indicator Circuit Malfunction

Conditions for Running the DTC

- The ignition is ON.
- The system voltage is 9-18 volts.

Conditions for Setting the DTC

- The system monitors the voltage on the Neutral indicator control circuit.
- If the system detects a voltage 3.5 volts or less when the Neutral indicator is not commanded, the DTC is logged.
- If the system detects a voltage 3.5 volts or more when the Neutral indicator is commanded, the DTC is logged.

Action Taken When the DTC Sets

2007 Hummer H3

2007 TRANSMISSION Transfer Case - BW 4493/4494 - H3

The SERVICE 4WD indicator will remain illuminated for the remainder of the current ignition cycle.

Conditions for Clearing the DTC

- The transfer case shift control module will clear the DTC if the condition for setting the DTC is not currently present.
- A history DTC will clear after 33 consecutive ignition cycles without a fault present.
- History DTCs can be cleared using a scan tool.

Test Description

The numbers below refer to the step numbers on the diagnostic table.

2: This step tests for voltage at the ignition 3 voltage side of the transfer case select switch.

3: This step tests the control circuit of the Neutral indicator for a short to voltage or an open.

4: This step tests the control circuit of the Neutral indicator for a short to ground.

DTC B0790

Step	Action	Yes	No
Schematic Reference: <u>Transfer Case Control Schematics</u>			
Connector End View Reference: <u>Transfer Case Control Connector End Views</u>			
1	Did you perform the Diagnostic System Check - Vehicle?	Go to Step 2	Go to <u>Diagnostic System Check - Vehicle</u>
2	<ol style="list-style-type: none">1. Turn the ignition OFF.2. Remove the transfer case select switch.3. Disconnect the connector on the transfer case select switch.4. Turn the ignition ON.5. Probe the Ignition 3 voltage circuit with a DMM that is connected to a good ground.		
	Does the DMM indicate battery voltage?	Go to Step 3	Go to Step 6
	Test the Neutral indicator control circuit for a		

2007 Hummer H3

2007 TRANSMISSION Transfer Case - BW 4493/4494 - H3

3	short to voltage or an open. Refer to <u>Circuit Testing</u> and <u>Wiring Repairs</u> . Did you find and correct the condition?	Go to Step 9	Go to Step 4
4	Test the control circuit of the Neutral indicator for a short to ground. Refer to <u>Testing for Short to Ground</u> and <u>Wiring Repairs</u> . Did you find and correct the condition?	Go to Step 9	Go to Step 5
5	Inspect for poor connections at the harness connector of the transfer case shift control module and the transfer case shift control switch. Refer to <u>Testing for Intermittent Conditions and Poor Connections</u> and <u>Connector Repairs</u> . Did you find and correct the condition?	Go to Step 9	Go to Step 7
6	Test the Neutral feed circuit of the transfer case select switch for an open, high resistance or short to ground. Refer to <u>Circuit Testing</u> and <u>Wiring Repairs</u> . Did you find and correct the condition?	Go to Step 9	-
7	Replace the transfer case select switch and clear all DTCs. Refer to <u>Transfer Case Shift Control Switch Replacement</u> . Does the DTC reset?	Go to Step 8	System OK
8	Replace the transfer case shift control module. Refer to <u>Control Module References</u> for replacement, setup and programming. Did you complete the repair?	Go to Step 9	-
9	<ol style="list-style-type: none"> 1. Use the scan tool in order to clear the DTCs. 2. Operate the vehicle within the Conditions for Running the DTC as specified in the supporting text. Does the DTC reset?	Go to Step 1	System OK

2007 Hummer H3

2007 TRANSMISSION Transfer Case - BW 4493/4494 - H3

Circuit Description

The mode switch circuit consists of 5 modes. The transfer case shift control module supplies a regulated 5 volts, DC to the switch through the 5-volt regulator circuit. The current travels through the resistor of the currently pressed mode button. The current is then returned to the transfer case shift control module through the switch signal circuit.

The transfer case shift control module constantly monitors this signal voltage to determine the condition of the mode switch circuit.

When each of the modes are selected they will complete a circuit through their own specific resistor while the button is pressed. The transfer case shift control module continuously monitors the switch input to determine whether the Neutral, Differential Lock, 4HI, 4HI Lock or 4LO Lock mode was selected by the driver.

DTC Descriptor

This diagnostic procedure supports the following DTC:

DTC B2725 ATC Mode Switch Circuit Malfunction

Conditions for Running the DTC

- The ignition is ON.
- The system voltage is 9-18 volts.

Conditions for Setting the DTC

- The system constantly monitors the voltage on switch signal circuit.
- If the system detects a voltage level under 0.3 volt or greater than 0.75 volts for 60 seconds, the DTC is logged.

Action Taken When the DTC Sets

- All shifting will be disabled.
- The SERVICE 4WD indicator will remain illuminated for the remainder of the current ignition cycle.

Conditions for Clearing the DTC

- The transfer case shift control module will clear the current DTC if the condition for setting the DTC is not currently present.

2007 Hummer H3

2007 TRANSMISSION Transfer Case - BW 4493/4494 - H3

- A history DTC will clear after 33 consecutive ignition cycles without a fault present.
- History DTCs can be cleared using a scan tool.

Test Description

The numbers below refer to the step numbers on the diagnostic table.

- 2:** This step tests for proper operation of the transfer case mode select switch.
- 3:** This step tests the mode switch for proper resistance values in all mode switch states.
- 4:** This step tests for proper voltage on the 5-volt reference circuit.
- 5:** This step tests the 5-volt reference circuit for an open, high resistance, short to voltage or short to ground.
- 6:** This step tests the switch signal circuit for an open, high resistance, short to voltage or short to ground.

DTC B2725

Step	Action	Values	Yes	No
Schematic Reference: <u>Transfer Case Control Schematics</u>				
Connector End View Reference: <u>Transfer Case Control Connector End Views</u>				
1	Did you perform the Diagnostic System Check - Vehicle?	-	Go to Step 2	Go to <u>Diagnostic System Check - Vehicle</u>
2	1. Install a scan tool. 2. Start the engine. 3. Set the Park brake. 4. Place the transmission into Neutral. 5. With a scan tool, observe the Mode Switch Selected parameter. 6. Select each of the modes. Does the scan tool indicate that the transfer case is in the mode that is selected?	-	Go to <u>Testing for Intermittent Conditions and Poor Connections</u>	Go to Step 3

2007 Hummer H3

2007 TRANSMISSION Transfer Case - BW 4493/4494 - H3

<p align="center">3</p>	<p>1. Disconnect and remove the mode switch.</p> <p>2. Connect a DMM between the switch signal and 5 volt reference pins on the switch.</p> <p>3. Measure the resistance through the mode switch while pressing and holding each of the mode buttons and comparing values.</p> <p>Does the DMM indicate all resistance values within the specified ranges?</p>	<p>Neutral 2,424-2,574 ohms 4 HI 3,553- 3,773 ohms 4 HI Lock 1,817-1,930 ohms 4 LO Lock 5,256-5,581 ohms Differential Lock 747- 793 ohms Normal 16,878- 17,922 ohms</p>	<p>Go to Step 4</p>	<p>Go to Step 7</p>
<p align="center">4</p>	<p>Check the voltage on the 5-volt reference circuit.</p> <p>Was the voltage within the specified range?</p>	<p>4.8-5.1 V</p>	<p>Go to Step 6</p>	<p>Go to Step 5</p>
<p align="center">5</p>	<p>Test the 5-volt reference circuit for an open, short to ground, short to voltage or high resistance. Refer to <u>Circuit Testing</u> and <u>Wiring Repairs</u> .</p> <p>Did you find and correct the condition?</p>	<p align="center">-</p>	<p>Go to Step 9</p>	<p>Go to Step 8</p>
<p align="center">6</p>	<p>Test the switch signal circuit for a short to voltage, short to ground, open or high resistance. Refer to <u>Circuit Testing</u> and <u>Wiring Repairs</u> .</p> <p>Did you find and correct the condition?</p>	<p align="center">-</p>	<p>Go to Step 9</p>	<p>Go to Step 8</p>
<p align="center">7</p>	<p>Replace the mode switch. Refer to <u>Transfer Case Shift Control Switch Replacement</u>.</p> <p>Did you complete the repair?</p>	<p align="center">-</p>	<p>Go to Step 9</p>	<p align="center">-</p>

2007 Hummer H3

2007 TRANSMISSION Transfer Case - BW 4493/4494 - H3

8	Replace the transfer case shift control module. Refer to Control Module References for replacement, setup and programming. Did you complete the repair?	-	Go to Step 9	-
9	1. Use the scan tool in order to clear the DTCs. 2. Operate the vehicle within the Conditions for Running the DTC as specified in the supporting text. Does the DTC reset?	-	Go to Step 2	System OK

DTC C0306

Circuit Description

The transfer case motor is a bi-directional, permanent magnet, D.C. motor. When energized, through motor control A or motor control B, the ground is provided by the opposing motor control circuit and then grounded through the transfer case shift control module ground circuit, the motor, through a series of gears, rotates a shaft which moves the mode and range forks to shift the transfer case between the following ranges:

- 4HI
- 4HI Lock
- 4LO Lock
- Neutral

This DTC detects an open, short to voltage or short to ground in the motor control A or motor control B circuits or an open or short to ground inside the motor.

DTC Descriptor

This diagnostic procedure supports the following DTC:

DTC C0306 Motor A or B Circuit Malfunction

Conditions for Running the DTC

2007 Hummer H3

2007 TRANSMISSION Transfer Case - BW 4493/4494 - H3

- The ignition is ON.
- The system voltage is 9-18 volts.

Conditions for Setting the DTC

- The system will test the motor circuits by checking for unwanted voltage.
- Then, the system supplies voltage on each of the motor circuits and reads the voltage back on the other circuit.
- If the system detects a problem with the circuits, the DTC is logged. The transfer case shift control module senses a low voltage return in the motor control A or motor control B circuits when a high voltage is expected.
- The fault must remain current for 1.2 seconds to set the DTC.

Action Taken When the DTC Sets

- All shifting will be disabled.
- The SERVICE 4WD indicator will remain illuminated for the remainder of the current ignition cycle.

Conditions for Clearing the DTC

- The transfer case shift control module will clear the DTC if the condition for setting the DTC is not currently present.
- A history DTC will clear after 100 consecutive ignition cycles without a fault present.
- History DTCs can be cleared using a scan tool.

Test Description

The numbers below refer to the step numbers on the diagnostic table.

- 2:** This step tests motor A driver high for proper operation.
- 3:** This step tests motor B driver high for proper operation.
- 4:** This step tests motor A driver low for proper operation.
- 5:** This step tests motor B driver low for proper operation.
- 6:** This step tests motor control A and motor control B circuits for being shorted together.
- 7:** This step tests motor control A for a short to ground, short to voltage, open or high resistance.
- 8:** This step tests motor control B for a short to ground, short to voltage, open or high resistance.

2007 Hummer H3

2007 TRANSMISSION Transfer Case - BW 4493/4494 - H3

DTC C0306

Step	Action	Value(s)	Yes	No
Schematic Reference: <u>Transfer Case Control Schematics</u>				
Connector End View Reference: <u>Transfer Case Control Connector End Views</u>				
1	Did you perform the Diagnostic System Check - Vehicle?	-		Go to <u>Diagnostic System Check - Vehicle</u>
2	<ol style="list-style-type: none"> 1. Engage the parking brake. 2. Turn the ignition OFF and raise the vehicle on a hoist. Refer to <u>Lifting and Jacking the Vehicle</u> . 3. Disconnect the motor encoder connector at the transfer case. 4. Turn the ignition ON. 5. With a digital multimeter (DMM), measure voltage by probing the motor control A circuit and take the other lead to a good ground. 6. With a scan tool, command motor A driver high ON. <p>Does the DMM indicate battery voltage?</p>	-	Go to Step 2	Go to Step 7
3	<ol style="list-style-type: none"> 1. With a DMM, measure voltage by probing the motor control B circuit and take the other lead to a good ground. 2. With a scan tool, command motor B driver 	-		

2007 Hummer H3

2007 TRANSMISSION Transfer Case - BW 4493/4494 - H3

	high ON. Does the DMM indicate battery voltage?		Go to Step 4	Go to Step 8
4	<ol style="list-style-type: none"> 1. With a DMM, measure voltage by probing the motor control A circuit and take the other lead to ground. 2. With a scan tool, command motor A driver low ON. <p>Does the voltage on the DMM match the voltage indicated?</p>	0 V	Go to Step 5	Go to Step 7
5	<ol style="list-style-type: none"> 1. With a DMM, measure voltage by probing the motor control B circuit and use the other lead to probe one of the four encoder signal circuits. 2. With a scan tool, command motor B driver low ON. <p>Does the DMM indicate voltage within the specified range?</p>	4.3-4.7 V	Go to Step 6	Go to Step 8
6	<p>With a DMM, check motor control A and motor control B circuits for being shorted together.</p> <p>Did you find and correct the condition?</p>	-	Go to Step 11	Go to Step 9
7	<p>With a DMM, check the motor control A circuit for a short to ground, short to voltage, open or high resistance.</p> <p>Refer to Circuit Testing and</p>	-		

2007 Hummer H3

2007 TRANSMISSION Transfer Case - BW 4493/4494 - H3

	Wiring Repairs . Did you find and correct the condition?		Go to Step 11	Go to Step 10
8	With a DMM, check the motor control B circuit for a short to ground, short to voltage, open or high resistance. Refer to Circuit Testing and Wiring Repairs . Did you find and correct the condition?	-	Go to Step 11	Go to Step 10
9	Replace the encoder motor. Refer to Transfer Case Motor/Encoder Replacement. Did you complete the repair?	-	Go to Step 11	-
10	Replace the transfer case shift control module. Refer to Control Module References for replacement, setup and programming. Did you complete the repair?	-	Go to Step 11	-
11	<ol style="list-style-type: none"> 1. Use the scan tool in order to clear the DTCs. 2. Operate the vehicle within the Conditions for Setting the DTC as specified in the supporting text. Does the DTC reset?	-	Go to Step 2	System OK

DTC C0327

Circuit Description

The transfer case shift control module has four encoder channels, P, C, A and B, which are supplied 5 volts each. The four encoder channels each run to a switch located inside the encoder/motor assembly. When a particular encoder channel is active the switch is closed and 5 volts flows through the encoder signal return circuit. If the module wants to request motor position a low side driver pulls the voltage low on the encoder signal return and the

corresponding channel circuit indicating motor position.

The transfer case shift control module supplies 5 volts on all encoder channels, thus as these channels are pulled to ground, the module can interpret the location of the transfer case shift position.

This DTC detects an open, high resistance or a short to voltage, in the encoder signal return circuit or an open, high resistance or short to voltage in the encoder channel circuits.

DTC Descriptor

This diagnostic procedure supports the following DTC:

DTC C0327 Encoder Circuit Malfunction**Conditions for Running the DTC**

- The ignition is ON.
- The system voltage is 9-18 volts.

Conditions for Setting the DTC

The transfer case shift control module reads back a high voltage when a low voltage is expected or low voltage when a high voltage is expected on the encoder channel circuits or the encoder signal return circuit.

Action Taken When the DTC Sets

- All motor activity will stop.
- All the transfer case shift control switch mode indicators will be commanded OFF.
- The SERVICE 4WD indicator will be latched on for the remainder of the current ignition cycle.
- If a new mode is requested while the DTC is present either current or history, the indicator for the mode requested will flash for 15 seconds and then go out.

Conditions for Clearing the DTC

- The transfer case shift control module will clear the DTC if the condition for setting the DTC no longer exists.
- A history DTC will clear after 33 consecutive ignition cycles without a fault present.
- History DTCs can be cleared using a scan tool.

2007 Hummer H3

2007 TRANSMISSION Transfer Case - BW 4493/4494 - H3

Test Description

The numbers below refer to the step numbers on the diagnostic table.

- 2:** This step determines if 2 or more of the 5 volts encoder signal circuits are shorted together.
- 3:** This step checks for proper voltage on the 4 encoder signal circuits.
- 4:** This step tests for a short to voltage, open or high resistance on the encoder low reference circuit.
- 5:** This step determines which encoder signal circuits are shorted together.
- 6:** This step determines if any of the encoder signal circuits have an open or high resistance condition.
- 7:** This step determines if a binding shift detent lever shaft is causing the DTC.

DTC C0327

Step	Action	Value(s)	Yes	No
Schematic Reference: <u>Transfer Case Control Schematics</u> Connector End View Reference: <u>Transfer Case Control Connector End Views</u>				
1	Did you perform the Diagnostic System Check - Vehicle?	-	Go to Step 2	Go to <u>Diagnostic System Check - Vehicle</u>
2	1. Set the parking brake. 2. Raise the vehicle on a hoist. Refer to <u>Lifting and Jacking the Vehicle</u> in General Information. 3. Disconnect the connector at the transfer case. 4. Turn the ignition ON, with the engine OFF. 5. Install a scan tool. 6. While monitoring the encoder channels on the scan tool, short to ground each of the encoder channel circuits on	-		

2007 Hummer H3

2007 TRANSMISSION Transfer Case - BW 4493/4494 - H3

	<p>the module side of the harness with a jumper wire.</p> <p>Do more than one of the four encoder channels indicate OFF when each encoder channel circuit is individually shorted to ground?</p>		Go to Step 5	Go to Step 3
3	<p>Using a DMM at the transfer case connector, test the encoder signal circuits on the module side of the harness.</p> <p>Are the voltages within the specified range?</p>	4.3-4.7 V	Go to Step 4	Go to Step 6
4	<p>With the ignition in the OFF position, test the encoder low reference circuit for a short to ground, short to voltage, open or high resistance. Refer to <u>Circuit Testing</u> and <u>Wiring Repairs</u> .</p> <p>Did you find and correct the condition?</p>	-	Go to Step 11	Go to Step 7
5	<ol style="list-style-type: none"> 1. Disconnect C1 and C2 from the transfer case shift control module. 2. Using a DMM, check for 2 or more encoder signal circuits being shorted together. Refer to <u>Circuit Testing</u> and <u>Wiring Repairs</u> . <p>Did you find and correct the condition?</p>	-	Go to Step 11	Go to Step 10
6	<p>Test the suspect circuits for a short to ground, short to voltage, open or high resistance. Refer to <u>Circuit Testing</u> and <u>Wiring Repairs</u> .</p> <p>Did you find and correct the condition?</p>	-	Go to Step 11	Go to Step 10

2007 Hummer H3

2007 TRANSMISSION Transfer Case - BW 4493/4494 - H3

7	<p>1. Remove the encoder motor. 2. Inspect the shift detent lever shaft for a binding condition. Refer to <u>Transfer Case Motor/Encoder Replacement</u>.</p> <p>Did the shift detent lever shaft bind?</p>	-	Go to Step 8	Go to Step 9
8	<p>Remove the transfer case for disassembly and repair. Refer to <u>Transfer Case Disassemble</u>. Did you complete the repair?</p>	-	Go to Step 11	-
9	<p>Replace the encoder motor. Refer to <u>Transfer Case Motor/Encoder Replacement</u>. Did you complete the repair?</p>	-	Go to Step 11	-
10	<p>Replace the transfer case shift control module. Refer to <u>Control Module References</u> for replacement, setup and programming. Did you complete the repair?</p>	-	Go to Step 11	-
11	<p>1. Use the scan tool in order to clear the DTCs. 2. Operate the vehicle within the Conditions for Running the DTC as specified in the supporting text.</p> <p>Does the DTC set?</p>	-	Go to Step 1	System OK

DTC C0329

Circuit Description

The transfer case shift control module has 4 encoder channels coming out of it which are all supplied 5 volts. These 4 channels are P, C, A and B, each running to a switch located inside the encoder/motor assembly. When a particular encoder channel is active, the switch is closed and 5

2007 Hummer H3

2007 TRANSMISSION Transfer Case - BW 4493/4494 - H3

volts flows through the encoder signal return circuit. If the module wants to request motor position, a low side driver pulls the voltage low on the encoder signal return and the corresponding channel circuit indicating motor position.

The transfer case shift control module supplies 5 volts on all the channels. As these channels are pulled to ground, the module can interpret the location of the transfer case shift position.

This DTC detects a short to ground in the encoder signal return circuit or a short to ground in the encoder channel circuits.

DTC Descriptor

This diagnostic procedure supports the following DTC:

DTC C0329 Encoder Signal Circuit Low

Conditions for Running the DTC

- The ignition is ON.
- The system voltage is 9-18 volts.

Conditions for Setting the DTC

The transfer case shift control module can command the low side driver on the encoder signal return circuit not to pull the signal low. The module can then read the voltage on each of the encoder channel circuits. If the voltage is low a short to ground is indicated and the DTC is logged.

Action Taken When the DTC Sets

- All motor activity will stop.
- All the transfer case shift control switch mode indicators will be commanded OFF.
- The SERVICE 4WD indicator will be commanded ON and an active DTC set, when a shift is requested.
- If a shift is not being requested the DTC will go to history.
- If a new mode is requested while the DTC is present either current or history, the indicator for the mode requested will flash for 15 seconds and then go out.

Conditions for Clearing the DTC

- The transfer case shift control module will clear the DTC if the condition for setting the DTC no longer exists.

2007 Hummer H3

2007 TRANSMISSION Transfer Case - BW 4493/4494 - H3

- A history DTC will clear after 33 consecutive ignition cycles without a fault present.
- History DTCs can be cleared using a scan tool.

Test Description

The numbers below refer to the step numbers on the diagnostic table.

- 2:** This step determines if one or more of the encoder channel circuits are shorted to ground.
- 3:** This step checks with a digital multimeter (DMM) for a short to ground on any of the 4 encoder channel circuits.
- 4:** This step checks the encoder sign return circuit for a short to ground.
- 5:** This step determines if a faulty transfer case shift control module is causing the DTC to set.
- 6:** This step determines if the encoder motor is causing the DTC to set.

DTC C0329

Step	Action	Value(s)	Yes	No
Schematic Reference: <u>Transfer Case Control Schematics</u>				
Connector End View Reference: <u>Transfer Case Control Connector End Views</u>				
1	Did you perform the Diagnostic System Check - Vehicle?	-	Go to Step 2	Go to <u>Diagnostic System Check - Vehicle</u>
2	<ol style="list-style-type: none"> 1. Set the parking brake. 2. Raise the vehicle on a hoist. Refer to <u>Lifting and Jacking the Vehicle</u> . 3. Disconnect the connector at the transfer case. 4. Turn the ignition ON, with the engine OFF. 5. Install a scan tool. 6. Monitor the encoder channels P, B, A and C on the scan tool. <p>Do any of the encoder channels</p>	-		

2007 Hummer H3

2007 TRANSMISSION Transfer Case - BW 4493/4494 - H3

	indicate OFF?		Go to Step 3	Go to Step 4
3	Test the encoder channel circuit that is indicating OFF on the scan tool for a short to ground. Refer to <u>Circuit Testing</u> and <u>Wiring Repairs</u> . Did you find and correct the condition?	-	Go to Step 9	Go to Step 8
4	With the ignition in the OFF position, test the encoder low reference circuit for a short to ground. Refer to <u>Circuit Testing</u> and <u>Wiring Repairs</u> . Did you find and correct the condition?	-	Go to Step 9	Go to Step 5
5	1. Turn the ignition ON with the engine OFF. 2. With the transfer case connector still disconnected, use the scan tool to clear DTCs. Does DTC C0329 reset?	-	Go to Step 8	Go to Step 6
6	1. Turn the ignition OFF. 2. Connect the transfer case connector. 3. Turn the ignition ON, with the engine OFF. 4. With the transfer case shift control switch, command the transfer case through all of the modes. 5. Using a scan tool, check DTCs. Does DTC C0329 set?	-	Go to Step 7	Go to <u>Testing for Electrical Intermittents</u>
	Replace the encoder motor.			

2007 Hummer H3

2007 TRANSMISSION Transfer Case - BW 4493/4494 - H3

7	Refer to <u>Transfer Case Motor/Encoder Replacement</u> . Did you complete the repair?	-	Go to Step 9	-
8	Replace the transfer case shift control module. Refer to <u>Control Module References</u> for replacement, setup and programming. Did you complete the repair?	-	Go to Step 9	-
9	1. Use the scan tool in order to clear the DTCs. 2. Operate the vehicle within the Conditions for Running the DTC as specified in the supporting text. Does the DTC set?	-	Go to Step 1	System OK

DTC C0359

Circuit Description

The 4WD low circuit is used to notify the powertrain control module (PCM) that the vehicle is in 4WD low range. The PCM supplies 12 volts to this circuit. The transfer case shift control module grounds this circuit when the vehicle is in 4WD low range.

This DTC detects a short-to-ground, short-to-voltage or an open in the 4WD low circuit.

DTC Descriptor

This diagnostic procedure supports the following DTC:

DTC C0359 Four Wheel Drive Low Range (4WD low) Discrete Output Circuit Malfunction

Conditions for Running the DTC

- The ignition is ON.
- The system voltage is 9-18 volts.

Conditions for Setting the DTC

2007 Hummer H3

2007 TRANSMISSION Transfer Case - BW 4493/4494 - H3

- After the transfer case shift control module grounds the output, the 4WD low circuit and reads back a high voltage, the DTC is set. The system will not attempt setting the DTC again during that ignition cycle.
- The transfer case shift control module reads back a high voltage when a low voltage is expected on the 4WD low circuit.

Action Taken When the DTC Sets

- The transmission shift points may be affected.
- The SERVICE 4WD indicator will be latched on for the remainder of the current ignition cycle.

Conditions for Clearing the DTC

- The transfer case shift control module will clear the DTC if the condition for setting the DTC is not currently present.
- A history DTC will clear after 33 consecutive ignition cycles without a fault present.
- History DTCs can be cleared using a scan tool.

Test Description

The numbers below refer to the step numbers on the diagnostic table.

2: This step tests for proper reference voltage to the transfer case shift control module on the 4WD low circuit.

3: This step tests the 4WD Low circuit for a short-to-voltage.

4: This step tests the 4WD Low circuit for an open or high resistance.

5: This step repairs the 4WD Low circuit for a short-to-voltage.

DTC C0359

Step	Action	Values	Yes	No
Schematic Reference: <u>Transfer Case Control Schematics</u>				
Connector End View Reference: <u>Transfer Case Control Connector End Views</u>				
1	Did you perform the Diagnostic System Check - Vehicle?	-	Go to Step 2	Go to <u>Diagnostic System Check - Vehicle</u>
	1. Turn the ignition OFF.			

2007 Hummer H3

2007 TRANSMISSION Transfer Case - BW 4493/4494 - H3

2	<p>2. Disconnect the transfer case shift control module.</p> <p>3. Turn the ignition ON, with the engine OFF.</p> <p>4. Measure the voltage between the 4WD low circuit harness and ground.</p> <p>Is the voltage reading within the specified values?</p>	10-13.5 V	Go to Step 3	Go to Step 4
3	<p>1. Disconnect the PCM.</p> <p>2. Measure the voltage between the 4WD Low circuit harness and ground.</p> <p>Is the voltage reading within the specified value?</p>	0 V	Go to Step 7	Go to Step 5
4	<p>Test the 4WD low circuit for an open, high resistance or short to ground. Refer to <u>Circuit Testing</u> and <u>Wiring Repairs</u> .</p> <p>Did you find and correct the condition?</p>	-	Go to Step 8	Go to Step 6
5	<p>Repair the 4WD low circuit for short-to-voltage. Refer to <u>Wiring Repairs</u> .</p> <p>Did you find and correct the condition?</p>	-	Go to Step 8	-
6	<p>Replace the PCM. Refer to <u>Control Module References</u> for replacement, setup and programming.</p> <p>Did you complete the repair?</p>	-	Go to Step 8	-
7	<p>Replace the transfer case shift control module. Refer to <u>Control Module References</u> for replacement, setup and programming.</p>	-		-

2007 Hummer H3

2007 TRANSMISSION Transfer Case - BW 4493/4494 - H3

	Did you complete the repair?		Go to Step 8	
8	<ol style="list-style-type: none">1. Use the scan tool in order to clear the DTCs.2. Operate the vehicle within the Conditions for Running the DTC as specified in the supporting text.	-		
	Does the DTC reset?		Go to Step 2	System OK

DTC C0550

Circuit Description

At each power-up the transfer case shift control module runs a self-test on the following functions:

- EEPROM Checksum
- ROM Checksum
- RAM Checksum
- RAM Malfunction

DTC Descriptor

This diagnostic procedure supports the following DTC:

DTC C0550 ECU Malfunction

Conditions for Running the DTC

- The ignition is ON.
- The system voltage is 9-18 volts.

Conditions for Setting the DTC

- Critical operational parameters stored in EEPROM have failed Checksum test indicating invalid data.
- Masked ROM code has failed Checksum test indicating that masked ROM data is not currently valid.
- ROM code has failed Checksum test indicating that ROM data is not currently valid.

2007 Hummer H3

2007 TRANSMISSION Transfer Case - BW 4493/4494 - H3

- One or more ROM locations have failed operational test indicating that some portions of RAM are not functional.

Action Taken When the DTC Sets

- The SERVICE 4WD indicator will be latched on and the system will be disabled.
- The transfer case control switch will display the current position LED while DTC C0550 is current, but further shifting will be disabled.

Conditions for Clearing the DTC

- Replace the transfer case shift control module.
- Perform the Diagnostic System Check - Vehicle.

Test Description

The number below refers to the step number on the diagnostic table.

2: This step replaces the transfer case shift control module.

DTC C0550

Step	Action	Yes	No
Schematic Reference: <u>Transfer Case Control Schematics</u>			
Connector End View Reference: <u>Transfer Case Control Connector End Views</u>			
1	Did you perform the Diagnostic System Check - Vehicle?	Go to Step 2	Go to <u>Diagnostic System Check - Vehicle</u>
2	Replace the transfer case shift control module. Refer to <u>Control Module References</u> for replacement, setup and programming. Is the repair complete?	System OK	-

SYMPTOMS - TRANSFER CASE

IMPORTANT: 1. Perform the **Diagnostic System Check - Vehicle** before using the Symptom Tables in order to verify that the following statements are true:

- There are no diagnostic trouble codes (DTCs) present.

- **The control module or modules can communicate via the serial data link.**
- 2. Review the system operation in order to familiarize yourself with the system functions. Refer to Transfer Case Description and Operation.**

Visual/Physical Inspection

- Inspect for aftermarket devices which could affect the operation of the automatic transfer case system. Refer to Checking Aftermarket Accessories .
- Inspect the easily accessible or visible system components for obvious damage or conditions which could cause the symptom.
- Inspect the automatic transfer case for the proper fluid level.

Intermittent

Faulty electrical connections or wiring may be the cause of intermittent conditions. Refer to Testing for Intermittent Conditions and Poor Connections .

Symptom List

Refer to a symptom diagnostic procedure from the following list in order to diagnose the symptom:

- Electronic Rear Differential Lock Will Not Engage
- Electronic Rear Differential Lock Will Not Disengage
- Transfer Case Shift Control Switch Inoperative
- Transfer Case Shift Control Switch Indicator Always On - Two or More
- Transfer Case Shift Control Switch Indicator Flashes, then Returns to Previous Mode
- Transfer Case Shift Control Switch Indicator Inoperative - One or More
- Service Indicator Always On
- Service Indicator Inoperative
- Transfer Case Popping Noise
- Transfer Case Whine or Rumble Noise
- Transfer Case Growl or Grinding Noise
- Transfer Case Clunk in 4HI Lock

- **Transfer Case Clunk in 4LO Lock**
- **Transfer Case Clunk during Acceleration and Deceleration**
- **Transfer Case Shudder or Binding**
- **Transfer Case Will Not Shift**
- **Transfer Case Jumps Out of Gear**
- **Transfer Case Leak Diagnosis**

TRANSFER CASE SHIFT CONTROL SWITCH INOPERATIVE

Circuit Description

The range/mode switch circuit consists of the following 5 switches:

- 4HI
- 4HI Lock
- 4LO Lock
- Differential Lock
- Neutral

The transfer case shift control module supplies a regulated 5 volts, DC, to the switch through the 5 volt regulator circuit. The current travels through the resistor of the currently active switch. The switch then returns the current to the transfer case shift control module through the switch signal circuit.

The transfer case shift control module constantly monitors this signal voltage to determine the condition of the mode switch circuit.

When each switch is depressed, the switch will complete a circuit through the respective resistor. The transfer case shift control module continuously monitors the switch input to determine which of the following buttons is selected by the driver:

- 4HI
- 4HI Lock
- 4LO Lock
- Differential Lock

Test Description

2007 Hummer H3

2007 TRANSMISSION Transfer Case - BW 4493/4494 - H3

The numbers below refer to the step numbers on the diagnostic table.

2: This step tests the functionality of the mode switch.

3: This step tests the modules ability to operate the transfer case modes.

Transfer Case Shift Control Switch Inoperative

Step	Action	Yes	No
Schematic Reference: <u>Transfer Case Control Schematics</u>			
Connector End View Reference: <u>Transfer Case Control Connector End Views</u>			
1	Did you perform the Diagnostic System Check - Vehicle?	Go to Step 2	Go to Diagnostic System Check - Vehicle
2	<ol style="list-style-type: none"> 1. Install a scan tool. 2. Start the engine. 3. Place the transmission into Neutral. 4. Set the park brake. 5. Observe the Mode Switch Selected parameter on the scan tool while selecting each of the mode positions on the switch. <p>Does the state change with the selection of each of the mode positions?</p>	Go to Step 5	Go to Step 3
3	<p>Test the switch signal and 5-volt reference circuits for an open, high resistance, short to ground and short to voltage. Refer to <u>Circuit Testing</u> and <u>Wiring Repairs</u> .</p> <p>Did you find and correct the condition?</p>	Go to Step 6	Go to Step 4
4	<p>Replace the mode selection switch. Refer to <u>Transfer Case Shift Control Switch Replacement</u>.</p> <p>Did you complete the repair?</p>	Go to Step 6	-
5	<p>Replace the transfer case shift control module. Refer to <u>Control Module References</u> for replacement, setup and programming.</p> <p>Did you complete the repair?</p>	Go to Step 6	-

2007 Hummer H3

2007 TRANSMISSION Transfer Case - BW 4493/4494 - H3

6	1. Use the scan tool in order to clear the DTCs. 2. Operate the vehicle in order to determine if the symptom has been corrected.	Go to Step 2	System OK
Is the symptom still present?			

TRANSFER CASE SHIFT CONTROL SWITCH INDICATOR ALWAYS ON - TWO OR MORE

Circuit Description

The indicator lamps circuit consist of the following 5 individual lamps contained inside the mode/range switch assembly:

- 4HI
- 4HI Lock
- 4LO Lock
- Differential Lock
- Neutral

The following lamps are contained inside the respective mode button for each lamp:

- 4HI
- 4HI Lock
- 4LO Lock
- Differential Lock

When the ignition in ON, the transfer case shift control module illuminates the indicator that corresponds to the current gear position by providing a ground through a current limiting driver.

The transfer case shift control module flashes each indicator lamp after a shift has been requested and will continue to flash until the transfer case shift control module can complete the shift.

A solid state circuit located inside the switch supplies ignition voltage to the lamps. The solid state circuit also receives voltage whenever the headlamp switch is in the parklamp or headlamp position. When the solid state circuit receives voltage from the headlamp switch, the switch reduces the voltage supplied to the indicator lamps, dimming the lamps when the headlamps are ON.

2007 Hummer H3

2007 TRANSMISSION Transfer Case - BW 4493/4494 - H3

Test Description

The numbers below refer to the step numbers on the diagnostic table.

2: This step tests the transfer case electrical control of the lamp circuits.

3: This step tests the suspect lamp circuits for a short to ground.

Transfer Case Shift Control Switch Indicator Always On - Two or More

Step	Action	Yes	No
Schematic Reference: Transfer Case Control Schematics			
Connector End View Reference: Transfer Case Control Connector End Views			
1	Did you perform the Diagnostic System Check - Vehicle?	Go to Step 2	Go to Diagnostic System Check - Vehicle
2	<ol style="list-style-type: none"> Turn the ignition ON, with the engine OFF. Install a scan tool. Use the scan tool in order to command all the indicator lamps OFF. <p>Do all the lamps go OFF?</p>	Go to Step 7	Go to Step 3
3	<ol style="list-style-type: none"> Use the scan tool in order to determine the transfer case mode. Use this information to determine which lamp circuits are at fault. Disconnect the mode switch. Test the suspect lamp circuits for a short to ground. Refer to Circuit Testing and Wiring Repairs . <p>Is the suspect circuit shorted to ground?</p>	Go to Step 4	Go to Step 6
4	<ol style="list-style-type: none"> Disconnect the transfer case shift control module. Test the suspect lamp circuits for a short to ground. Refer to Circuit Testing and Wiring Repairs . 		

2007 Hummer H3

2007 TRANSMISSION Transfer Case - BW 4493/4494 - H3

	Is the suspect circuit shorted to ground?	Go to Step 5	Go to Step 7
5	Repair short to ground in the suspect lamp circuit. Refer to Circuit Testing and Wiring Repairs . Did you find and correct the condition?	Go to Step 8	-
6	Replace the mode switch. Refer to Transfer Case Shift Control Switch Replacement . Is the repair complete?	Go to Step 8	-
7	Replace the transfer case shift control module. Refer to Control Module References for replacement, setup and programming. Is the repair complete?	Go to Step 8	-
8	<ol style="list-style-type: none">1. Use the scan tool in order to clear the DTCs.2. Operate the vehicle in order to determine if the symptom has been corrected. Is the symptom still present?	Go to Step 2	System OK

TRANSFER CASE SHIFT CONTROL SWITCH INDICATOR FLASHES, THEN RETURNS TO PREVIOUS MODE

Circuit Description

The transfer case shift control module flashes each indicator lamp after a shift has been requested and continues to flash until the transfer case shift control module can complete the shift. If the transfer case is unable to make a shift, the requested mode indicator flashes and returns to the previous mode. If the requested mode indicator flashes for 15 seconds and returns to the previous mode, this indicates the loss of a necessary input from another module. The transfer case shift control module requires a vehicle speed sensor (VSS) signal, provided by the antilock brake system (ABS) module and a PRNDL input provided by the transmission. These signals are provided to the transfer case shift control module via class 2 and if not received the transfer case will not shift.

If a new mode is requested and the requested mode indicator flashes less than 15 seconds and returns to the previous mode, this indicates a transfer case fault. This symptom is caused by an internal mechanical transfer case fault causing the shift detent lever shaft to bind or a fault within the encoder motor.

2007 Hummer H3

2007 TRANSMISSION Transfer Case - BW 4493/4494 - H3

Test Description

The numbers below refer to the step numbers on the diagnostic table.

- 2:** This step tests for the possibility of a missing system input or a system fault.
- 3:** This step tests for a missing PRNDL input from the transmission.
- 4:** This step tests for a missing VSS signal from the ABS system.
- 5:** This step determines if the condition is caused by a faulty encoder motor or a mechanical internal fault to the transfer case.

Transfer Case Shift Control Switch Indicator Flashes, then Returns to Previous Mode

Step	Action	Yes	No
Schematic Reference: <u>Transfer Case Control Schematics</u> Connector End View Reference: <u>Transfer Case Control Connector End Views</u>			
1	Did you perform the Diagnostic System Check - Vehicle?	Go to Step 2	Go to <u>Diagnostic System Check - Vehicle</u>
2	1. Turn ON the ignition, with the engine OFF. 2. Place the vehicle in Neutral. 3. Select a different mode on the transfer case shift control switch. Does the switch flash the full 15 seconds?	Go to Step 3	Go to Step 5
3	1. Connect a scan tool to the vehicle. 2. Test for transmission DTCs indicating loss of the PRNDL signal. Is a DTC set?	Go to <u>Diagnostic Trouble Code (DTC) List - Vehicle</u>	Go to Step 4
4	With the scan tool, test for ABS DTCs indicating a loss of VSS. Is a DTC set?	Go to <u>Diagnostic Trouble Code (DTC) List - Vehicle</u>	Go to <u>Testing for Intermittent Conditions and Poor Connections</u>
	1. Remove the transfer case encoder		

2007 Hummer H3

2007 TRANSMISSION Transfer Case - BW 4493/4494 - H3

5	<p>motor, while leaving the electrical harness connected.</p> <p>2. Attempt to shift the transfer case to a different mode.</p> <p>Is the encoder motor able to make the shift?</p>	Go to Step 7	Go to Step 6
6	<p>Replace the transfer case encoder motor. Refer to <u>Transfer Case Motor/Encoder Replacement</u>.</p> <p>Is the repair complete?</p>	Go to Step 8	-
7	<p>Remove the transfer case and repair, for a shift detent lever shaft binding condition. Refer to <u>Transfer Case Disassemble</u>.</p> <p>Is the repair complete?</p>	Go to Step 8	-
8	<p>1. Use the scan tool in order to clear the DTCs.</p> <p>2. Operate the vehicle in order to determine if the symptom has been corrected.</p> <p>Is the symptom still present?</p>	-	System OK

TRANSFER CASE SHIFT CONTROL SWITCH INDICATOR INOPERATIVE - ONE OR MORE

Circuit Description

The indicator lamps circuit consist of the following 5 individual lamps contained inside the mode/range switch assembly:

- 4HI
- 4HI Lock
- 4LO Lock
- Differential Lock
- Neutral

The following lamps are contained inside the respective mode button for each lamp:

- 4HI
- 4HI Lock

2007 Hummer H3

2007 TRANSMISSION Transfer Case - BW 4493/4494 - H3

- 4LO Lock
- Differential Lock

When the ignition is ON, the transfer case shift control module illuminates the indicator lamp that corresponds to the current automatic transfer case (ATC) gear position by providing a ground through a current limiting driver.

The transfer case shift control module flashes each indicator lamp after a shift has been requested and will continue to flash until the transfer case shift control module can complete the shift.

A solid state circuit located inside the switch supplies ignition voltage to the lamps. The solid state circuit also receives voltage whenever the headlamp switch is in the parklamp or headlamp position. When the solid state circuit receives voltage from the headlamp switch it will reduce the voltage that it supplies to the indicator lamps, dimming the lamps when the headlamps are ON.

Test Description

The numbers below refer to the step numbers on the diagnostic table.

- 2:** This step determines if the module can command the indicators ON.
- 3:** This step determines if the indicator or wiring is at fault.
- 4:** This step tests the lamp feed circuit for an open or high resistance.
- 5:** This step tests the LED dimming circuit for an open or short to ground.

Transfer Case Shift Control Switch Indicator Inoperative - One or More

Step	Action	Yes	No
Schematic Reference: <u>Transfer Case Control Schematics</u> Connector End View Reference: <u>Transfer Case Control Connector End Views</u>			
1	Did you perform the Diagnostic System Check - Vehicle?	Go to Step 2	Go to <u>Diagnostic System Check - Vehicle</u>
2	1. Turn ON the ignition, with the engine OFF. 2. Install a scan tool. 3. Use the scan tool in order to command all the indicator lamps ON.	Go to <u>Testing for Intermittent Conditions and</u>	

2007 Hummer H3

2007 TRANSMISSION Transfer Case - BW 4493/4494 - H3

	Do all the lamps turn ON?	<u>Poor Connections</u>	Go to Step 3
3	<p>IMPORTANT: Do not damage a connector or circuit when back probing.</p> <ol style="list-style-type: none"> 1. Access the back of the mode switch. 2. Using a fused jumper back probe the effected indicator control circuit to ground. 		
	Does the effected lamp turn ON?	Go to Step 4	Go to Step 5
4	<p>Test the effected indicator control circuit for an open or high resistance. Refer to <u>Circuit Testing</u> and <u>Wiring Repairs</u> . Was the condition found and corrected?</p>	Go to Step 8	Go to Step 7
5	<p>Test the LED dimming circuit for an open or short to ground. Refer to <u>Circuit Testing</u> and <u>Wiring Repairs</u> . Was the condition found and corrected?</p>	Go to Step 8	Go to Step 6
6	<p>Replace the mode switch. Refer to <u>Transfer Case Shift Control Switch Replacement</u>. Is the repair complete?</p>	Go to Step 8	-
7	<p>Replace the transfer case shift control module. Refer to <u>Control Module References</u> for replacement, setup and programming. Is the repair complete?</p>	Go to Step 8	-
8	<ol style="list-style-type: none"> 1. Use the scan tool in order to clear the DTCs. 2. Operate the vehicle in order to determine if the symptom has been corrected. 		
	Is the symptom still present?	Go to Step 2	System OK

SERVICE INDICATOR ALWAYS ON

2007 Hummer H3

2007 TRANSMISSION Transfer Case - BW 4493/4494 - H3

Circuit Description

The Service 4WD indicator is located in the instrument panel cluster (IPC) and shares the common power and ground of the IPC. The transfer case shift control module controls the Service indicator by sending the IPC a Class 2 message. This indicator may be controlled with the scan tool using the IPC device controls.

Test Description

The number below refers to the step number on the diagnostic table.

2: This step determines whether the failure is the result of a malfunctioning transfer case shift control module or the IPC.

Service Indicator Always On

Step	Action	Yes	No
Schematic Reference: <u>Transfer Case Control Schematics</u> Connector End View Reference: <u>Transfer Case Control Connector End Views</u>			
1	Did you perform the Diagnostic System Check - Vehicle?	Go to Step 2	Go to <u>Diagnostic System Check - Vehicle</u>
2	Observe the Service 4WD parameter input/output in the instrument panel cluster (IPC) Scan Tool Data List. Is the Service 4WD indicator commanded ON?	Go to Step 3	Go to Step 4
3	Replace the transfer case shift control module. Refer to <u>Control Module References</u> for replacement, setup and programming. Did you complete the repair?	Go to Step 5	-
4	Replace the IPC. Refer to <u>Instrument Cluster Replacement (Left Hand Drive)</u> or <u>Instrument Cluster Replacement (Right Hand Drive)</u> . Did you complete the repair?	Go to Step 5	-
5	1. Use the scan tool in order to clear the DTCs. 2. Operate the vehicle in order to		

2007 Hummer H3

2007 TRANSMISSION Transfer Case - BW 4493/4494 - H3

	determine if the symptom has been corrected.		
	Is the symptom still present?	Go to Step 1	System OK

SERVICE INDICATOR INOPERATIVE

Circuit Description

The Service 4WD indicator is located in the instrument panel cluster (IPC) and shares the common power and ground of the IPC. The transfer case shift control module controls the Service indicator lamp by sending the IPC a Class 2 message. This lamp may be controlled with the scan tool using the IPC device controls.

Test Description

The number below refers to the step number on the diagnostic table.

2: This step determines whether the failure is the result of a faulty transfer case shift control module or the IPC.

Service Indicator Inoperative

Step	Action	Yes	No
Schematic Reference: <u>Transfer Case Control Schematics</u>			
Connector End View Reference: <u>Transfer Case Control Connector End Views</u>			
1	Did you perform the Diagnostic System Check - Vehicle?	Go to Step 2	Go to <u>Diagnostic System Check - Vehicle</u>
2	Observe the Service 4WD parameter input/output in the instrument panel cluster (IPC) Scan Tool Data List. Is the Service 4WD indicator commanded ON?	Go to Step 4	Go to Step 3
3	Replace the transfer case shift control module. Refer to <u>Control Module References</u> for replacement, setup and programming. Did you complete the repair?	Go to Step 5	-
	Replace the IPC. Refer to <u>Instrument</u>		

2007 Hummer H3

2007 TRANSMISSION Transfer Case - BW 4493/4494 - H3

4	<p><u>Cluster Replacement (Left Hand Drive) or Instrument Cluster Replacement (Right Hand Drive)</u> .</p> <p>Did you complete the repair?</p>	Go to Step 5	-
5	<p>1. Use the scan tool in order to clear the DTCs.</p> <p>2. Operate the vehicle in order to determine if the symptom has been corrected.</p> <p>Is the symptom still present?</p>	Go to Step 1	System OK

TRANSFER CASE POPPING NOISE

Transfer Case Popping Noise

Cause	Correction
<p>DEFINITION: A faulty internal transfer case component that causes a popping noise in the transfer case.</p> <p>Review the <u>Symptoms - Transfer Case</u> and perform the necessary inspections.</p>	
Chain jump	<ul style="list-style-type: none"> • Replace the chain and sprockets. Refer to <u>Transfer Case Disassemble</u> and <u>Transfer Case Assemble</u>. • Replace the shaft bearings. Refer to <u>Transfer Case Disassemble</u> and <u>Transfer Case Assemble</u>. • Inspect for damaged components caused by metal debris. Refer to <u>Transfer Case Disassemble</u> and <u>Transfer Case Assemble</u>.

TRANSFER CASE WHINE OR RUMBLE NOISE

Transfer Case Whine or Rumble Noise

Cause	Correction
<p>DEFINITION: A faulty internal transfer case component that causes a whine noise in the transfer case.</p> <p>Review the <u>Symptoms - Transfer Case</u> and perform the necessary inspections.</p>	
Faulty bearings	<ol style="list-style-type: none"> 1. Inspect all of the bearings and journals. Refer to <u>Cleaning and Inspection</u>. 2. Replace any faulty bearings and any components with

2007 Hummer H3

2007 TRANSMISSION Transfer Case - BW 4493/4494 - H3

faulty bearing journals. Refer to **Transfer Case Disassemble** and **Transfer Case Assemble**.

TRANSFER CASE GROWL OR GRINDING NOISE

Transfer Case Growl or Grinding Noise

Cause	Correction
DEFINITION: A faulty internal transfer case component that causes a growl or grinding noise in the transfer case while the vehicle is turning. Review the <u>Symptoms - Transfer Case</u> and perform the necessary inspections.	
High/low planetary carrier assembly	<ol style="list-style-type: none">1. Inspect the high/low planetary carrier pinion gears for the following conditions:<ul style="list-style-type: none">• Chipped, bent or deformed teeth• Pinion gear needle bearing worn• Pinion gear thrust washers missing• Seized or binding pinion gearsRefer to <u>Cleaning and Inspection</u>.2. Inspect the high/low planetary carrier input gear for excessive thrust end play.3. Inspect the input gear teeth for excessive wear or damage.4. Replace the high/low planetary carrier assembly if any of the above conditions exist. Refer to <u>Transfer Case Disassemble</u> and <u>Transfer Case Assemble</u>.
Ring gear	<ol style="list-style-type: none">1. Inspect the ring gear for teeth damage or wear. Refer to <u>Cleaning and Inspection</u>.2. Replace the ring gear if it is faulty. Refer to <u>Transfer Case Disassemble</u> and <u>Transfer Case Assemble</u>.
Planetary differential	<ol style="list-style-type: none">1. Inspect the planetary differential pinion gears for the following conditions:<ul style="list-style-type: none">• Chipped, bent or deformed teeth• Pinion gear bushings worn• Pinion gear thrust washers missing• Seized or binding pinion gears

2007 Hummer H3

2007 TRANSMISSION Transfer Case - BW 4493/4494 - H3

	<p align="center">Refer to <u>Cleaning and Inspection</u>.</p> <p>2. Inspect the planetary differential for deformation. Refer to <u>Cleaning and Inspection</u>.</p> <p>3. Replace the planetary differential assembly if it is faulty. Refer to <u>Transfer Case Disassemble</u> and <u>Transfer Case Assemble</u>.</p>
Sun gears	<p>1. Inspect the sun gears for the following conditions:</p> <ul style="list-style-type: none"> • Gear tooth failure • Worn or galled thrust surfaces <p align="center">Refer to <u>Cleaning and Inspection</u>.</p> <p>2. Replace the sun gears if they are faulty. Refer to <u>Transfer Case Disassemble</u> and <u>Transfer Case Assemble</u>.</p>
Thrust washers	<p>1. Inspect the thrust washers for seizure to the planetary differential.</p> <p>2. Inspect the thrust washers for galling.</p> <p>3. Replace the thrust washers if they are faulty and the mating component if it is damaged. Refer to <u>Transfer Case Disassemble</u> and <u>Transfer Case Assemble</u>.</p>
Planetary differential not timed properly	<p>1. Inspect the planetary differential for being timed properly. Refer to <u>Transfer Case Assemble</u>.</p> <p>2. Properly time the planetary differential gears. Refer to <u>Transfer Case Assemble</u>.</p>

TRANSFER CASE CLUNK IN 4HI LOCK

Transfer Case Clunk in 4HI Lock

Cause	Correction
<p>DEFINITION: During acceleration or deceleration, a clunk is heard or felt in the transfer case while in the 4HI Lock range only.</p> <p>Review the <u>Symptoms - Transfer Case</u> and perform the necessary inspections.</p>	
Incorrect fluid level or incorrect fluid	<p>1. Inspect the transfer case for the correct fluid level. Refer to <u>Transfer Case Fluid Replacement</u>.</p>

2007 Hummer H3

2007 TRANSMISSION Transfer Case - BW 4493/4494 - H3

	<ol style="list-style-type: none">2. Inspect the transfer case for the correct type of fluid.3. Flush the transfer case and fill with the correct fluid, if required. Refer to <u>Approximate Fluid Capacities</u>.
Worn high speed teeth on the range sleeve	<ol style="list-style-type: none">1. Inspect for worn high speed teeth on the range sleeve. Refer to <u>Cleaning and Inspection</u>.2. Replace the range sleeve if it is faulty. Refer to <u>Transfer Case Disassemble</u> and <u>Transfer Case Assemble</u>.
Worn or missing input gear thrust washer	Replace the worn or missing input gear thrust washer. Refer to <u>Transfer Case Disassemble</u> and <u>Transfer Case Assemble</u> .
Worn or faulty planetary differential	<ol style="list-style-type: none">1. Inspect the planetary differential for the following conditions:<ul style="list-style-type: none">• Loose planetary differential splines to mainshaft splines• Loose or faulty pinion gearsRefer to <u>Cleaning and Inspection</u>.2. Replace the planetary differential assembly if it is faulty. Refer to <u>Transfer Case Disassemble</u> and <u>Transfer Case Assemble</u>.
Worn or missing rear output shaft thrust washers	<ol style="list-style-type: none">1. Inspect to ensure the thrust washers are installed.2. Inspect the thrust washers and mating surface for excessive wear.3. Replace the worn or missing thrust washer. Refer to <u>Transfer Case Disassemble</u> and <u>Transfer Case Assemble</u>.
Worn or damaged rear sun gear	<ol style="list-style-type: none">1. Inspect the sun gear external gear teeth for excessive wear.2. Inspect the sun gear to rear output shaft for excessive looseness.3. Replace the sun gear or rear output shaft if it is worn. Refer to <u>Transfer Case Disassemble</u> and <u>Transfer Case Assemble</u>.
Rear output shaft bearing outer retaining ring	<ol style="list-style-type: none">1. Inspect for the following conditions:<ul style="list-style-type: none">• Properly installed rear output shaft bearing

2007 Hummer H3

2007 TRANSMISSION Transfer Case - BW 4493/4494 - H3

	<p>retaining ring</p> <ul style="list-style-type: none">• Excessive wear or damage to the retaining ring groove in the rear case half <p>Refer to <u>Cleaning and Inspection</u>.</p> <p>2. Repair or replace the following components if found faulty:</p> <ol style="list-style-type: none">1. Replace the rear output shaft bearing outer retaining ring.2. Replace the rear case half if the retaining ring groove is faulty. <p>Refer to <u>Transfer Case Disassemble</u> and <u>Transfer Case Assemble</u>.</p>
Lockup shift assembly hub	<p>1. Inspect the lockup shift assembly hub for the following conditions:</p> <ul style="list-style-type: none">• The hub internal teeth to inner lockup hub for excessive looseness caused by wear• The hub engagement teeth for wear <p>Refer to <u>Cleaning and Inspection</u>.</p> <p>2. Replace the lockup shift assembly if it is faulty. Refer to <u>Transfer Case Disassemble</u> and <u>Transfer Case Assemble</u>.</p>

TRANSFER CASE CLUNK IN 4LO LOCK

Transfer Case Clunk in 4LO Lock

Cause	Correction
DEFINITION: During acceleration or deceleration, a clunk is heard or felt in the transfer case while in 4LO Lock range only. Review the <u>Symptoms - Transfer Case</u> and perform the necessary inspections.	
High/low planetary carrier assembly	<p>1. Inspect for the following conditions:</p> <ul style="list-style-type: none">• Excessively worn planetary gears• The planetary gears loose in the planetary carrier

2007 Hummer H3

2007 TRANSMISSION Transfer Case - BW 4493/4494 - H3

	<ul style="list-style-type: none"> • The input gear for missing thrust washers or excessive thrust end play in the carrier • Excessively worn range sleeve engagement teeth on the carrier <p style="text-align: center;">Refer to <u>Cleaning and Inspection</u>.</p> <p>2. Replace the high/low planetary if any of the above conditions are found. Refer to <u>Transfer Case Disassemble</u> and <u>Transfer Case Assemble</u>.</p>
Ring gear	<ol style="list-style-type: none"> 1. Inspect the ring gear to front case fit for excessive looseness. 2. Inspect the front case for wear caused by excessive looseness. 3. Replace the front case half if it is worn.
Range sleeve	<ol style="list-style-type: none"> 1. Inspect the range sleeve engagement teeth for excessive wear. 2. Inspect the range sleeve to mainshaft splines for excessive wear. 3. Replace the range sleeve if it is faulty. Refer to <u>Transfer Case Disassemble</u> and <u>Transfer Case Assemble</u>.

TRANSFER CASE CLUNK DURING ACCELERATION AND DECELERATION

Transfer Case Clunk during Acceleration and Deceleration

Cause	Correction
<p>DEFINITION: During acceleration or deceleration, a clunk is heard or felt in the transfer case while in the 4HI mode.</p> <p>Review the <u>Symptoms - Transfer Case</u> and perform the necessary inspections.</p>	
Incorrect fluid level or incorrect fluid	<ol style="list-style-type: none"> 1. Inspect the transfer case for the correct fluid level. Refer to <u>Transfer Case Fluid Replacement</u>. 2. Inspect the transfer case for the correct type of fluid. 3. Flush the transfer case and fill with the correct fluid, if required. Refer to <u>Approximate Fluid Capacities</u>.
Excessive clearance between the slip yoke and	<ol style="list-style-type: none"> 1. Inspect for the following conditions: <ul style="list-style-type: none"> • Worn slip yoke splines

2007 Hummer H3

2007 TRANSMISSION Transfer Case - BW 4493/4494 - H3

the rear output shaft

- Worn rear output shaft splines
2. Repair or replace the following components, if faulty.
 - Replace the slip yoke, if required. Refer to **Rear Propeller Shaft Replacement** .
 - Replace the rear output shaft, if required. Refer to **Transfer Case Disassemble** and **Transfer Case Assemble**.

Excessive clearance between the slip yoke and the rear bushing

1. Inspect for the following conditions:
 - Worn rear bushing
 - Worn slip yoke bushing journal
2. Repair or replace the following components, if faulty.
 - Replace the slip yoke, if required. Refer to **Rear Propeller Shaft Replacement** .
 - Replace the rear case half if the rear bushing is worn. Refer to **Transfer Case Disassemble** and **Transfer Case Assemble**.

Worn high speed teeth on the range sleeve

1. Inspect for the following conditions:
 - Worn high speed teeth on the range sleeve
 - Worn or missing input gear thrust washers

Refer to **Cleaning and Inspection**.
2. Repair or replace the following components, if faulty.
 - Replace the range sleeve if it is worn. Refer to **Transfer Case Disassemble** and **Transfer Case Assemble**.
 - Replace the thrust washers, as required. Refer to **Transfer Case Disassemble** and **Transfer Case Assemble**.

Worn or faulty planetary differential

1. Inspect the planetary differential for the following conditions:
 - Loose planetary differential splines to the mainshaft splines
 - Loose or faulty pinion gears

2007 Hummer H3

2007 TRANSMISSION Transfer Case - BW 4493/4494 - H3

	<p>Refer to <u>Cleaning and Inspection</u>.</p> <p>2. Replace the planetary differential assembly if it is faulty. Refer to <u>Transfer Case Disassemble</u> and <u>Transfer Case Assemble</u>.</p>
Worn or missing rear output shaft thrust washers	<p>1. Inspect to ensure the thrust washers are installed.</p> <p>2. Inspect the thrust washers and mating surface for excessive wear.</p> <p>3. Replace the worn or missing thrust washer. Refer to <u>Transfer Case Disassemble</u> and <u>Transfer Case Assemble</u>.</p>
Worn or damaged rear sun gear	<p>1. Inspect the sun gear external gear teeth for excessive wear.</p> <p>2. Inspect the sun gear to rear output shaft for excessive looseness.</p> <p>3. Replace the sun gear or rear output shaft if it is worn. Refer to <u>Transfer Case Disassemble</u> and <u>Transfer Case Assemble</u>.</p>
Worn or damaged front sun gear	<p>1. Inspect the sun gear external gear teeth for excessive wear.</p> <p>2. Inspect the sun gear to drive gear teeth for excessive wear.</p> <p>3. Replace the sun gear or drive gear if it is worn. Refer to <u>Transfer Case Disassemble</u> and <u>Transfer Case Assemble</u>.</p>
Rear output shaft bearing outer retaining ring	<p>1. Inspect for the following conditions:</p> <ul style="list-style-type: none">• Proper installation of the rear output shaft bearing retaining ring• Excessive wear or damaged retaining ring groove in the rear case half <p>2. Repair or replace the following components if found faulty:</p> <ul style="list-style-type: none">• Properly install a new rear output shaft bearing outer retaining ring.• Replace the rear case half if the retaining ring

2007 Hummer H3

2007 TRANSMISSION Transfer Case - BW 4493/4494 - H3

groove is excessively worn.

Refer to **Transfer Case Disassemble** and **Transfer Case Assemble**.

TRANSFER CASE SHUDDER OR BINDING

Transfer Case Shudder or Binding

Cause	Correction
<p>DEFINITION: A shudder, binding or a crow-hop while turning, which may cause tire scuffing.</p> <p>Review the <u>Symptoms - Transfer Case</u> and perform the necessary inspections.</p>	
Intermittent shift lock up engagement	<ol style="list-style-type: none">1. Shift the vehicle into 4LO Lock or 4HI Lock.2. Shift the vehicle from 4LO Lock or 4HI Lock to the 4HI mode.3. Drive the vehicle and inspect for the shift lock up staying engaged after shifting from the 4LO Lock or 4HI Lock to the 4HI Mode. If the shift lock up stays engaged after shifting from 4LO Lock or 4HI Lock, it will give a symptom of both axles driving without any speed difference between the axles. It is noticed by tire scuffing on dry pavement when turning.4. Drive the vehicle in reverse for a few feet.5. Drive the vehicle forward and inspect for the shift lock up staying engaged. If the shift lock up disengaged after driving the vehicle in reverse this is normal and no further action is required.6. Advise the customer to drive the vehicle in reverse for a few feet if the shift lock up does not disengage after shifting out of 4LO Lock or 4HI Lock.
Planetary differential	<ol style="list-style-type: none">1. Inspect the planetary differential pinion gears for the following conditions:<ul style="list-style-type: none">• Chipped, bent or deformed teeth• Pinion gear bushings worn• Pinion gear thrust washers missing• Seized or binding pinion gears

2007 Hummer H3

2007 TRANSMISSION Transfer Case - BW 4493/4494 - H3

	<p align="center">Refer to <u>Cleaning and Inspection.</u></p> <p>2. Inspect the planetary differential for deformation. Refer to <u>Cleaning and Inspection.</u></p> <p>3. Replace the planetary differential assembly if it is faulty. Refer to <u>Transfer Case Disassemble</u> and <u>Transfer Case Assemble.</u></p>
Thrust washer	<p>1. Inspect the thrust washer for seizure to the planetary differential.</p> <p>2. Replace the thrust washer if it is faulty and the mating component if it is damaged. Refer to <u>Transfer Case Disassemble</u> and <u>Transfer Case Assemble.</u></p>
Planetary differential not timed properly	<p>1. Inspect the planetary differential for being timed properly. Refer to <u>Transfer Case Assemble.</u></p> <p>2. Properly time the planetary differential gears. Refer to <u>Transfer Case Assemble.</u></p>

TRANSFER CASE WILL NOT SHIFT

Transfer Case Will Not Shift

Cause	Correction
<p>DEFINITION: While shifting from HI range to LO range, there is gear clashing, no HI range or the transfer case will not shift from 4HI to 4HI Lock.</p> <p>Review the Symptoms - Transfer Case and perform the necessary inspections.</p>	
Shift cam and shaft assembly	<p>1. Inspect for the following conditions:</p> <ul style="list-style-type: none"> ● The shift cam for being worn ● The shift shaft torsion spring for being faulty <p align="center">Refer to <u>Cleaning and Inspection.</u></p> <p>2. Replace the following components if found faulty:</p> <ul style="list-style-type: none"> ● The shift cam ● The shift shaft torsion spring <p align="center">Refer to <u>Transfer Case Disassemble</u> and <u>Transfer Case Assemble.</u></p>
High/low range shift fork	<p>1. Inspect the high low shift fork for the following</p>

2007 Hummer H3

2007 TRANSMISSION Transfer Case - BW 4493/4494 - H3

	<p>conditions:</p> <ul style="list-style-type: none">• Worn shift fork pads• The roller on the shift fork for wear or damage• Cracked or bent shift fork <p>Refer to <u>Cleaning and Inspection</u>.</p> <p>2. Replace the following components if found faulty:</p> <ul style="list-style-type: none">• The shift fork pads• The shift fork <p>Refer to <u>Transfer Case Disassemble</u> and <u>Transfer Case Assemble</u>.</p>
Range sleeve	<p>1. Inspect the range sleeve for the following conditions:</p> <ul style="list-style-type: none">• Engagement teeth for burrs or damage• Sliding freely on the mainshaft• The range sleeve shift fork collar for excessive wear <p>Refer to <u>Cleaning and Inspection</u>.</p> <p>2. Replace the range sleeve if it is faulty. Refer to <u>Transfer Case Disassemble</u> and <u>Transfer Case Assemble</u>.</p>
High/low planetary carrier	<p>1. Inspect the high/low planetary engagement teeth for burrs or damage. Refer to <u>Cleaning and Inspection</u>.</p> <p>2. Replace the high/low planetary carrier if it is faulty. Refer to <u>Transfer Case Disassemble</u> and <u>Transfer Case Assemble</u>.</p>
Mainshaft front support bearing	<p>1. Inspect for the following conditions:</p> <ul style="list-style-type: none">• Failed front mainshaft support bearing in the input gear• Journal on the mainshaft for excessive wear or damage <p>Refer to <u>Cleaning and Inspection</u>.</p> <p>2. Replace the bearing if it is faulty. Refer to <u>Transfer</u></p>

2007 Hummer H3

2007 TRANSMISSION Transfer Case - BW 4493/4494 - H3

	<p align="center"><u>Case Disassemble</u> and <u>Transfer Case Assemble</u>.</p> <p>3. Replace the mainshaft if it is damaged. Refer to <u>Transfer Case Disassemble</u> and <u>Transfer Case Assemble</u>.</p>
Lockup shift collar assembly	<p>1. Inspect the lockup shift collar assembly for the following conditions:</p> <ul style="list-style-type: none"> • Shift hub for binding • Shift collar for damage • Burred or damaged engagement teeth <p align="center">Refer to <u>Cleaning and Inspection</u>.</p> <p>2. Replace the shift collar assembly if it is faulty. Refer to <u>Transfer Case Disassemble</u> and <u>Transfer Case Assemble</u>.</p>
Drive sprocket	<p>1. Inspect for the following conditions:</p> <ul style="list-style-type: none"> • Engagement teeth on the drive sprocket for burrs or damage • Worn bushing in the drive sprocket • Journal on the mainshaft for excessive wear or damage <p align="center">Refer to <u>Cleaning and Inspection</u>.</p> <p>2. Replace the drive gear if it is damaged. Refer to <u>Transfer Case Disassemble</u> and <u>Transfer Case Assemble</u>.</p> <p>3. Replace the mainshaft if it is damaged. Refer to <u>Transfer Case Disassemble</u> and <u>Transfer Case Assemble</u>.</p>

TRANSFER CASE JUMPS OUT OF GEAR

Transfer Case Jumps Out of Gear

Cause	Correction
<p>DEFINITION: Loss of the transfer case drive torque during deceleration, acceleration or under load.</p>	

2007 Hummer H3

2007 TRANSMISSION Transfer Case - BW 4493/4494 - H3

Review the **Symptoms - Transfer Case** and perform the necessary inspections.

Shift cam worn	<ol style="list-style-type: none">1. Inspect for excessive wear on the shift cam, not allowing full shift fork travel. Refer to <u>Cleaning and Inspection</u>.2. Replace the faulty shift cam. Refer to <u>Transfer Case Disassemble</u> and <u>Transfer Case Assemble</u>.
High/low shift fork pads	<ol style="list-style-type: none">1. Inspect the shift fork pads for wear. Refer to <u>Cleaning and Inspection</u>.2. Replace the fork pads or other damaged components. Refer to <u>Transfer Case Disassemble</u> and <u>Transfer Case Assemble</u>.
Faulty high speed teeth on range sleeve	<ol style="list-style-type: none">1. Inspect for the following conditions:<ul style="list-style-type: none">• The input gear high speed engagement teeth for wear or damage• The engagement teeth on the range sleeve for wear or damage<p>Refer to <u>Cleaning and Inspection</u>.</p>2. Replace the range sleeve if the teeth are faulty. Refer to <u>Transfer Case Disassemble</u> and <u>Transfer Case Assemble</u>.3. Replace the high/low planetary carrier assembly if the input gear engagement teeth are faulty. Refer to <u>Transfer Case Disassemble</u> and <u>Transfer Case Assemble</u>.
High/low planetary carrier	<ol style="list-style-type: none">1. Inspect the high/low planetary carrier for the following conditions:<ul style="list-style-type: none">• Low speed engagement teeth worn or damaged• Cracked carrier housing• Pinion gear bushings worn or out of position• Pinion gears broken or damaged teeth• Pinion gears seized<p>Refer to <u>Cleaning and Inspection</u>.</p>2. Replace the high/low planetary carrier if any of the

2007 Hummer H3

2007 TRANSMISSION Transfer Case - BW 4493/4494 - H3

	<p>above conditions are found. Refer to <u>Transfer Case Disassemble</u> and <u>Transfer Case Assemble</u>.</p>
Faulty high/low range fork	<ol style="list-style-type: none">1. Inspect the high/low range fork for damage or wear. Refer to <u>Cleaning and Inspection</u>.2. Replace the high/low range fork if it is faulty. Refer to <u>Transfer Case Disassemble</u> and <u>Transfer Case Assemble</u>.
Lockup shift collar assembly	<ol style="list-style-type: none">1. Inspect the lockup shift collar assembly for the following conditions:<ul style="list-style-type: none">• Worn or damaged sleeve• Lock up collar teeth worn or damagedRefer to <u>Cleaning and Inspection</u>.2. Replace the lockup shift collar assembly if it is faulty. Refer to <u>Transfer Case Disassemble</u> and <u>Transfer Case Assemble</u>.
Planetary differential	<ol style="list-style-type: none">1. Inspect the planetary differential for the following conditions:<ul style="list-style-type: none">• Cracked carrier housing• Pinion gear bushings worn or out of position• Pinion gears broken or damaged teeth• Pinion gears seizedRefer to <u>Cleaning and Inspection</u>.2. Replace the planetary differential if any of the above conditions are found. Refer to <u>Transfer Case Disassemble</u> and <u>Transfer Case Assemble</u>.
Mainshaft front support bearing	<ol style="list-style-type: none">1. Inspect the bearing in the input gear and the mainshaft journal for excessive wear. Refer to <u>Cleaning and Inspection</u>.2. Replace the bearing and the mainshaft if they are faulty. Refer to <u>Transfer Case Disassemble</u> and <u>Transfer Case Assemble</u>.
Sun gears	<ol style="list-style-type: none">1. Inspect the sun gears for broken or damaged teeth. Refer

2007 Hummer H3

2007 TRANSMISSION Transfer Case - BW 4493/4494 - H3

to **Cleaning and Inspection.**

2. Replace the sun gears if they are faulty. Refer to **Transfer Case Disassemble** and **Transfer Case Assemble.**

TRANSFER CASE LEAK DIAGNOSIS

Transfer Case Leak Diagnosis

Cause	Correction
DEFINITION: A visible indication of an external fluid leak from the transfer case. Review the <u>Symptoms - Transfer Case</u> and perform the necessary inspections.	
Drain plug or fill plug leak	<ol style="list-style-type: none">1. Inspect for the correct sealer and the correct amount of sealer on the plugs.2. Install the plugs correctly. Refer to <u>Transfer Case Fluid Replacement.</u>
Vehicle speed sensor (VSS) leaking	<ol style="list-style-type: none">1. Remove the VSS and inspect for the following conditions:<ul style="list-style-type: none">• Cross threaded• Cut or damaged O-ring seal• VSS over tightened causing deformation in the VSS<p>Refer to <u>Transfer Case Speed Sensor Replacement.</u></p>2. Replace the VSS O-ring seal if it is faulty. Refer to <u>Transfer Case Speed Sensor Replacement.</u>3. Replace the VSS if it is faulty. Refer to <u>Transfer Case Speed Sensor Replacement.</u>
Rear output shaft seal leaking	<ol style="list-style-type: none">1. Inspect for the following conditions:<ul style="list-style-type: none">• Overfilled or improper transfer case fluid• Blocked vent• Seal improperly installed, worn or damaged• Seal bore damaged or cracked• Rear output shaft bushing for excessive wear• Slip yoke seal surface for wear or pitting

2007 Hummer H3

2007 TRANSMISSION Transfer Case - BW 4493/4494 - H3

	<p>2. Repair or replace the following components if found faulty:</p> <ul style="list-style-type: none">• Adjust or replace the transfer case fluid. Refer to <u>Transfer Case Fluid Replacement</u>.• Clean or properly route the vent hose.• Replace the slip yoke if the surface could cause leakage. Refer to <u>Rear Propeller Shaft Replacement</u> .• Replace the rear output shaft bushing if it is worn. Refer to <u>Transfer Case Disassemble</u> and <u>Transfer Case Assemble</u>.• Replace the rear case half if the seal bore is damaged. Refer to <u>Transfer Case Disassemble</u> and <u>Transfer Case Assemble</u>.• Replace the rear output shaft seal. Refer to <u>Transfer Case Output Shaft Seal Replacement - Rear</u>.
Front output shaft seal leaking	<p>1. Inspect for the following conditions:</p> <ul style="list-style-type: none">• Overfilled or improper transfer case fluid• Blocked vent• Seal improperly installed, worn or damaged• Seal bore damaged or cracked <p>2. Repair or replace the following components if found faulty:</p> <ul style="list-style-type: none">• Adjust or replace the transfer case fluid. Refer to <u>Transfer Case Fluid Replacement</u>.• Clean or properly route the vent hose.• Replace the front case half if the seal bore is damaged. Refer to <u>Transfer Case Disassemble</u> and <u>Transfer Case Assemble</u>.• Replace the front output shaft seal. Refer to <u>Transfer Case Output Shaft Seal Replacement - Front</u>.
Shift shaft seal leaking	<p>1. Remove the encoder motor and inspect for the shift shaft seal leaking.</p>

2007 Hummer H3

2007 TRANSMISSION Transfer Case - BW 4493/4494 - H3

	<p>2. Replace the shift shaft seal. Refer to <u>Transfer Case Disassemble</u> and <u>Transfer Case Assemble</u>.</p>
Leaking at the vent	<p>1. Transfer case overfilled</p> <ol style="list-style-type: none">1. Inspect for the correct transfer case fluid level. Refer to <u>Transfer Case Fluid Replacement</u>.2. Inspect the transmission fluid level. Refer to <u>Transmission Fluid Check</u> .3. If the transmission fluid level is low and the transfer case fluid level is too high, replace the transfer case input shaft seal. Refer to <u>Transfer Case Input Shaft Seal Replacement</u>.4. Inspect for the following conditions:<ul style="list-style-type: none">• Seal improperly installed, worn or damaged• Seal bore damaged or cracked• Input shaft seal surface worn, grooved or damaged <p>2. Seal the vent with the correct sealer if it is leaking at the case. Refer to <u>Transfer Case Assemble</u>.</p>
Transfer case to adapter leak	<p>1. Inspect for the following conditions:</p> <ul style="list-style-type: none">• Loose mounting fasteners• Gasket or sealant faulty• The transfer case input shaft seal leaking <p>2. Repair or replace the following components if found faulty:</p> <ul style="list-style-type: none">• Replace the transfer case input shaft seal. Refer to <u>Transfer Case Input Shaft Seal Replacement</u>.• Inspect for the following conditions:<ul style="list-style-type: none">■ Seal improperly installed, worn or damaged■ Seal bore damaged or cracked■ Input shaft seal surface worn, grooved or damaged• Repair or replace the loose fasteners. Refer to <u>Transfer Case Adapter Replacement</u>.• Replace the transfer case gasket or sealer. Refer to

	<u>Transfer Case Adapter Replacement.</u>
Front case half to rear case half seam leak	Disassemble and seal the case halves again. Refer to <u>Transfer Case Disassemble</u> and <u>Transfer Case Assemble</u> .
Case leaking	<ol style="list-style-type: none"> 1. Inspect for a cracked case or case porosity. 2. Replace the faulty case half. Refer to <u>Transfer Case Disassemble</u> and <u>Transfer Case Assemble</u>.

REPAIR INSTRUCTIONS - ON VEHICLE

TRANSFER CASE SHIFT CONTROL MODULE REPLACEMENT

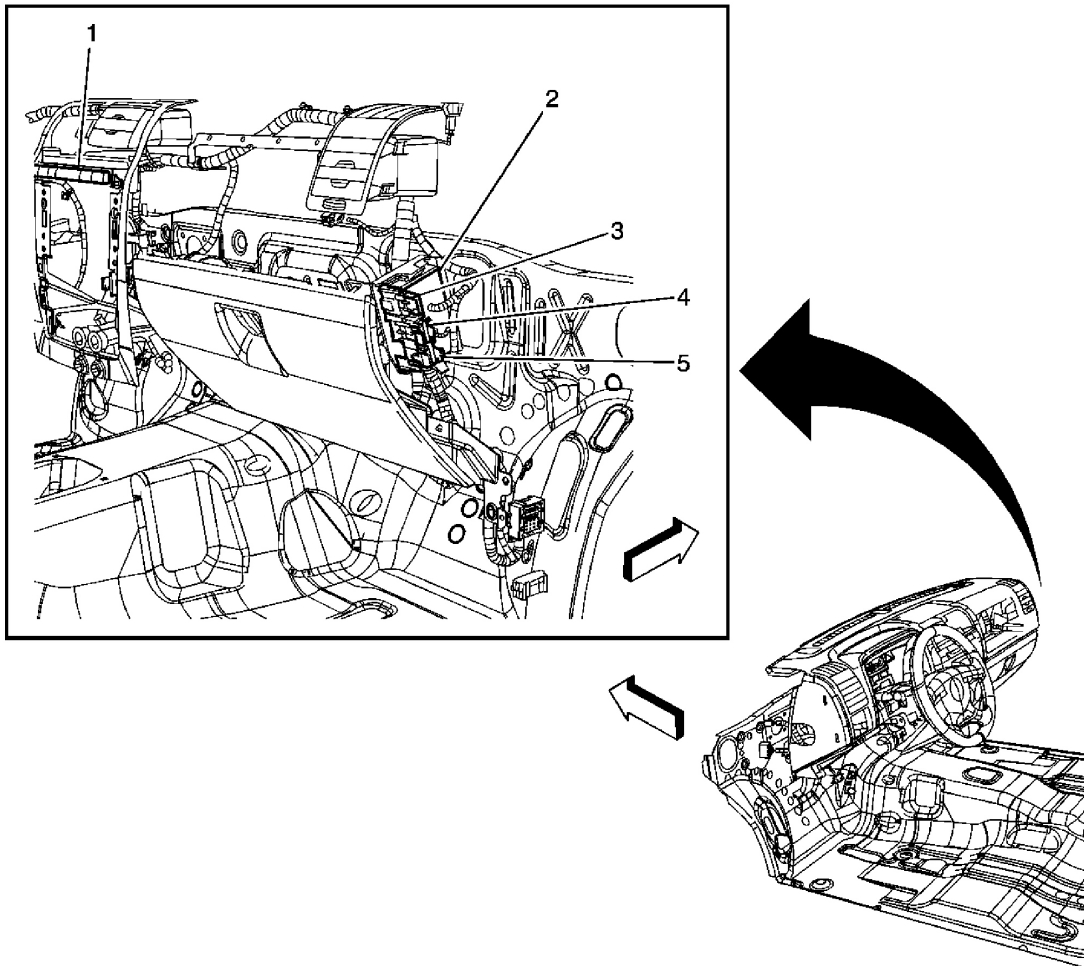

Fig. 12: Locating Transfer Case Shift Control Module
 Courtesy of GENERAL MOTORS CORP.

Transfer Case Shift Control Module Replacement

Callout	Component Name
Fastener Tightening Specifications: Refer to <u>Fastener Tightening Specifications</u> .	
Preliminary Procedure: Remove the instrument panel (I/P) closeout panel. Refer to <u>Instrument Panel Outer Trim Cover Replacement - Right Side (Left Hand Drive)</u> or <u>Instrument Panel Outer Trim Cover Replacement - Right Side (Right Hand Drive)</u> .	
1	Transfer Case Control Module Tip: Remove the control module from the mounting bracket before disconnecting the electrical connectors.
2	Transfer Case Control Module Electrical Connector

TRANSFER CASE SHIELD REPLACEMENT

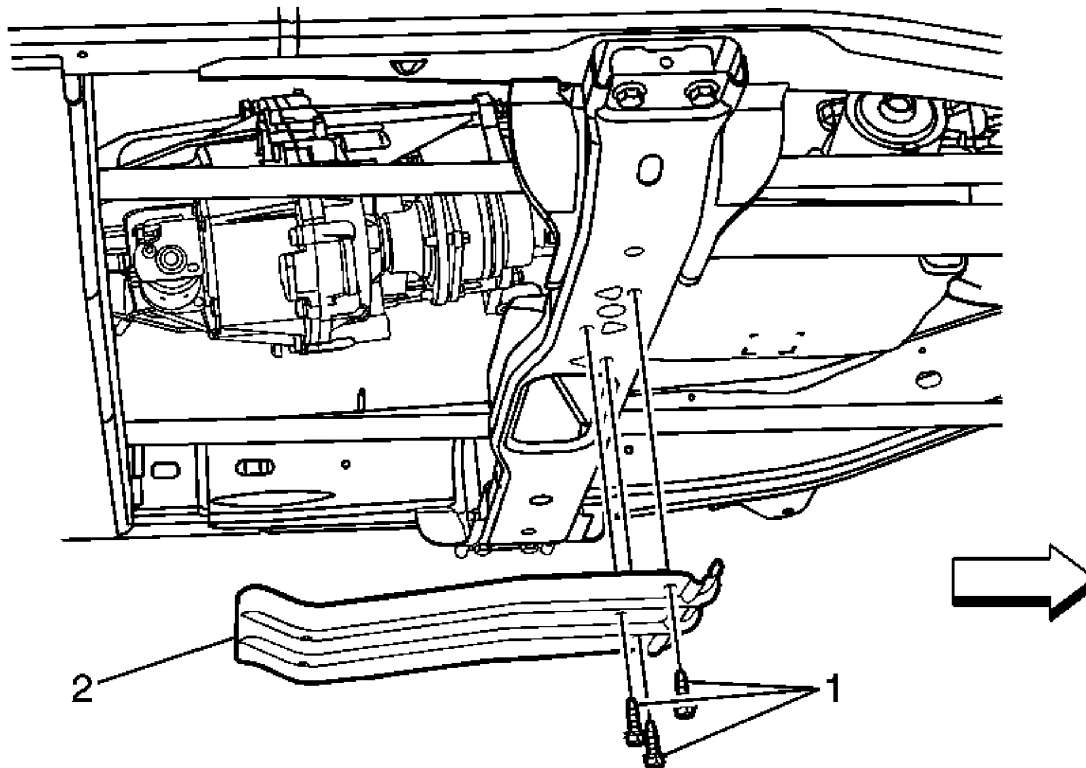

Fig. 13: Transfer Case Shield Replacement
Courtesy of GENERAL MOTORS CORP.

Transfer Case Shield Replacement

Callout	Component Name

2007 Hummer H3

2007 TRANSMISSION Transfer Case - BW 4493/4494 - H3

NOTE:

Refer to Fastener Notice .

Fastener Tightening Specifications: Refer to Fastener Tightening Specifications. **Preliminary Procedure:** Raise the vehicle. Refer to Lifting and Jacking the Vehicle .

1	Bolt, Transfer Case Shield (Qty: 2) Tighten: 30 N.m (23 lb ft)
2	Shield, Transfer Case

TRANSFER CASE FLUID REPLACEMENT

1. Raise the vehicle. Refer to Lifting and Jacking the Vehicle .
2. Determine the VIN of the vehicle:
 - If the VIN is 56TDN13E778100102 or prior, proceed to step 3.
 - If the VIN is after 56TDN13E778100102, perform steps 3-9 and 14 only.

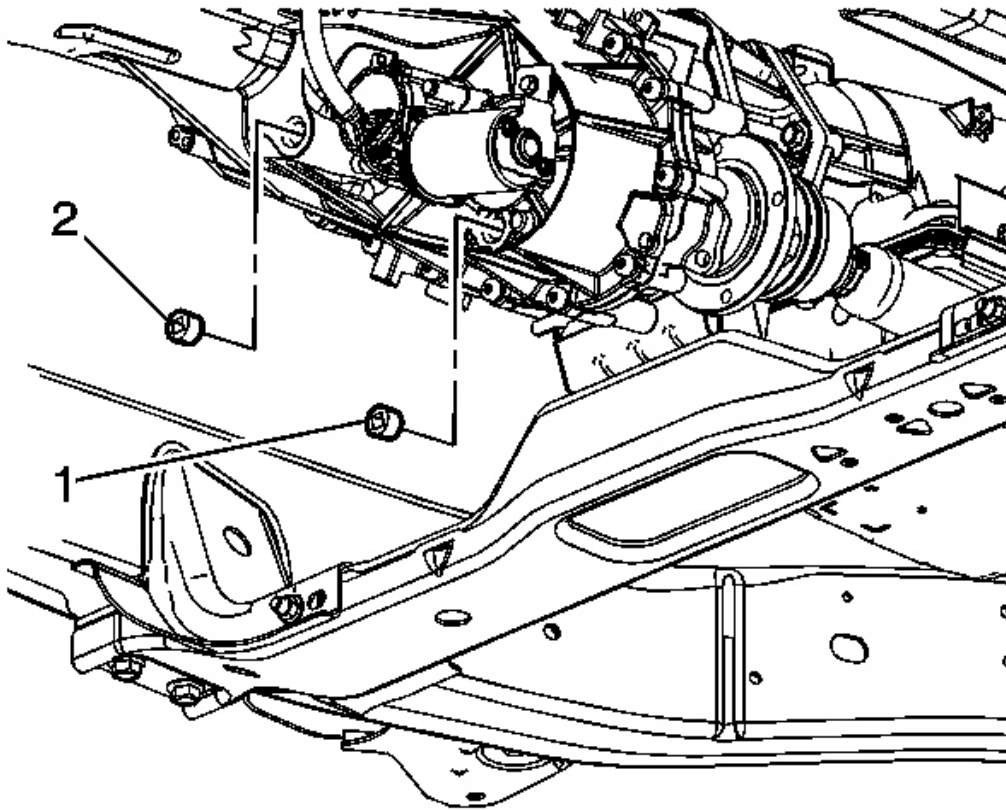

Fig. 14: Identifying Transfer Case Drain Plug
Courtesy of GENERAL MOTORS CORP.

3. Remove the transfer case drain plug (1) and drain the fluid.
4. Apply pipe sealant GM P/N 12346004 (Canadian P/N 10953480) to the threads of the transfer case drain plug.

NOTE: Refer to Fastener Notice .

5. Install the transfer case drain plug (1).

Tighten: Tighten the transfer case drain plug to 25 N.m (18 lb ft).

6. Remove the transfer case fill plug (2).
7. Fill the transfer case to the bottom of the fill hole with manual transmission and transfer case

fluid, G/M P/N 88861800 (Canadian P/N 88861801).

8. Apply pipe sealant G/M P/N 12346004 (Canadian P/N 10953480) to the threads of the transfer case plug.
9. Install the transfer case fill plug.

Tighten: Tighten the transfer case fill plug to 25 N.m (18 lb ft).

10. If the VIN is 56TDN13E778100102 or prior proceed to the next step, if not proceed to step 14.
11. Remove the speed sensor from the transfer case. Refer to **Transfer Case Speed Sensor Replacement**.

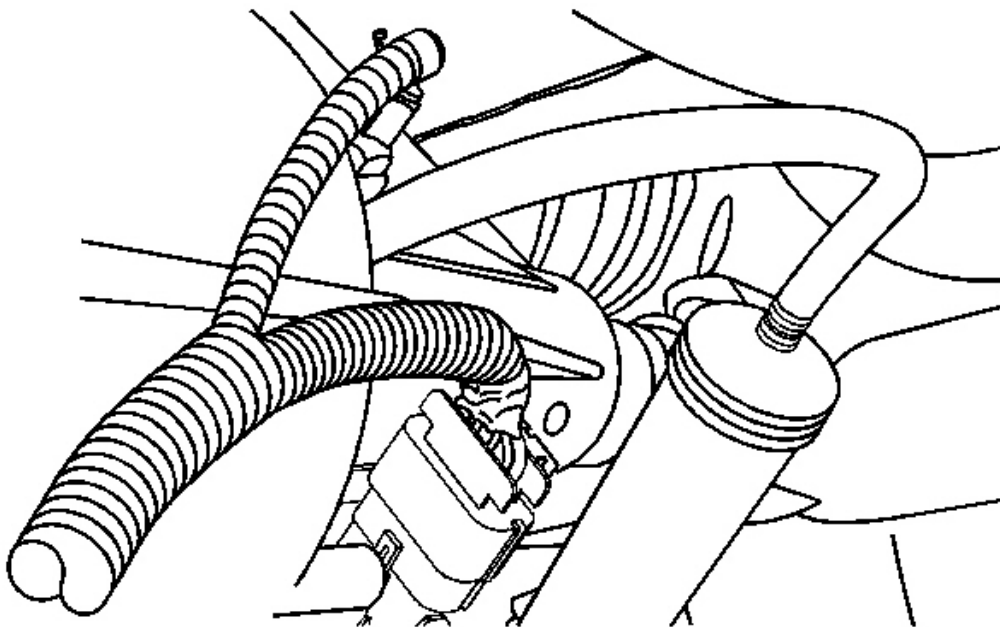

Fig. 15: Identifying Proper Hand Pump Position
Courtesy of GENERAL MOTORS CORP.

IMPORTANT: A hand pump or equivalent, will be required to perform step 12.

12. Add 250 ml (8.45 oz.) of manual transmission and transfer case fluid, GM P/N 88861800

(Canadian P/N 88861801), to the transfer case via the speed sensor hole.

NOTE: Refer to Component Fastener Tightening Notice .

13. Install the speed sensor to the top of the transfer case and connect the electrical connector.

Tighten: Tighten the speed sensor to 17 N.m (13 lb ft).

14. Lower the vehicle.

TRANSFER CASE MOTOR/ENCODER REPLACEMENT

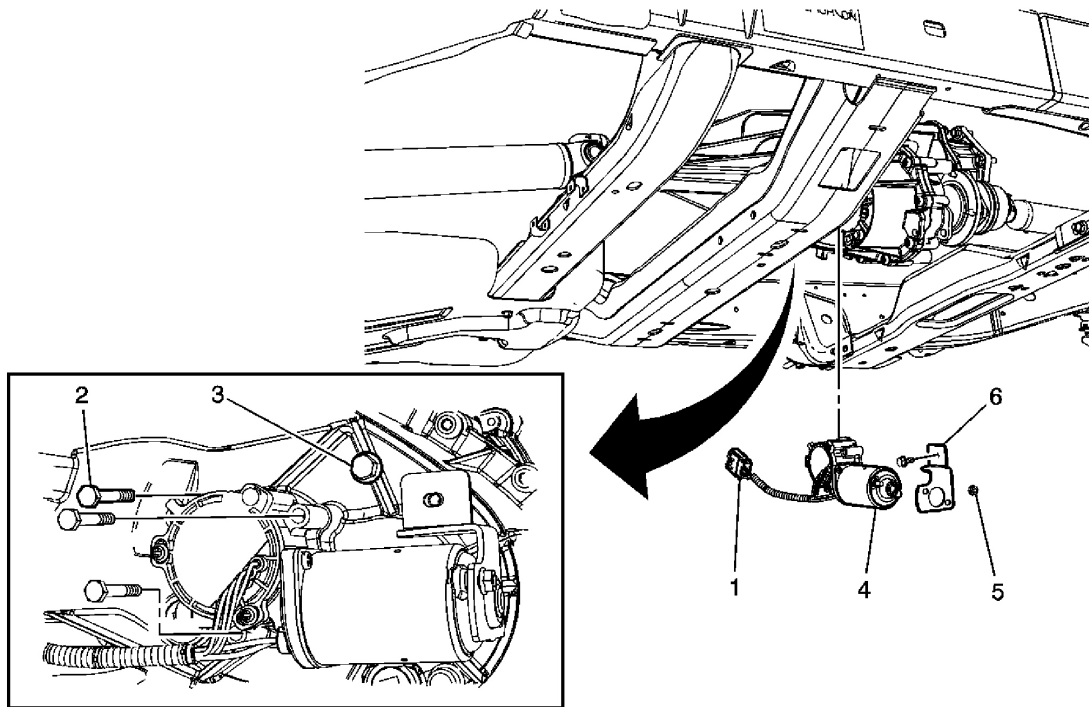

Fig. 16: Transfer Case Motor/Encoder Replacement
 Courtesy of GENERAL MOTORS CORP.

Transfer Case Motor/Encoder Replacement

Callout	Component Name
<p>NOTE: Refer to <u>Fastener Notice</u> .</p>	
<p>Fastener Tightening Specifications:</p>	<p>Refer to <u>Fastener Tightening Specifications</u> .</p>

Preliminary Procedures

1. Raise the vehicle. Refer to **Lifting and Jacking the Vehicle** .
2. Remove the transfer case shield. Refer to **Transfer Case Shield Replacement**.

1	Encoder Motor Electrical Connector
2	Mounting Encoder Motor Bolt (Qty: 3) Tighten: 10 N.m (89 lb in)
3	Encoder Motor Mounting Bracket Bolt Tighten: 10 N.m (89 lb in)
4	Encoder Assembly Motor
5	Encoder Motor Bracket Nut Tighten: 5 N.m (44 lb in)
6	Encoder Motor Bracket

TRANSFER CASE SPEED SENSOR REPLACEMENT

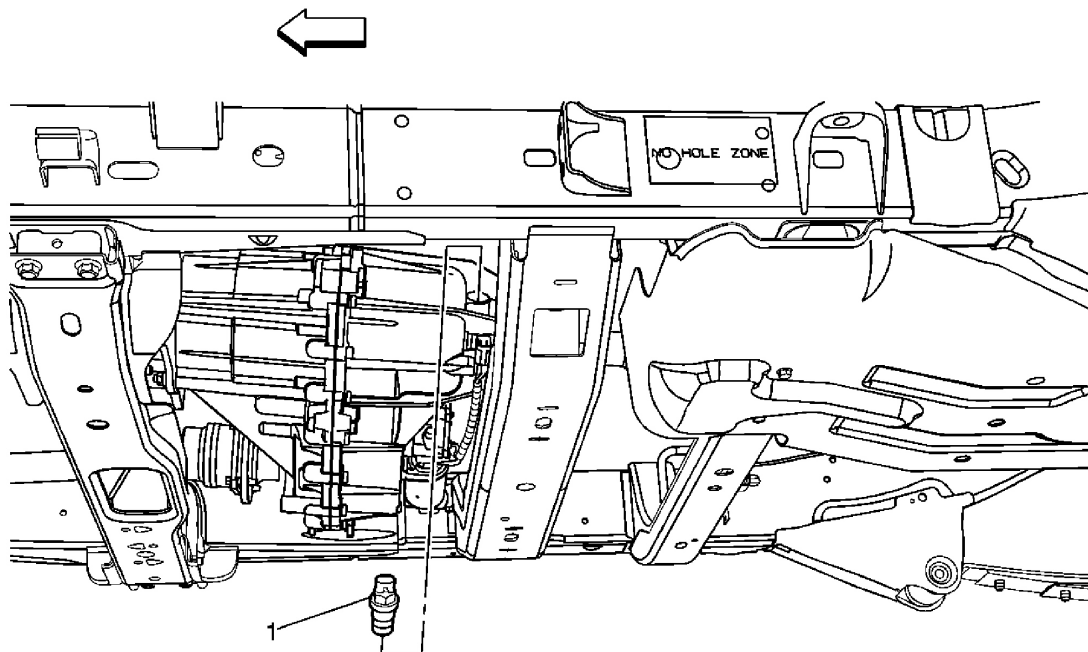

Fig. 17: Transfer Case Speed Sensor Replacement
 Courtesy of GENERAL MOTORS CORP.

Transfer Case Speed Sensor Replacement

Callout	Component Name
<p>NOTE: Refer to <u>Fastener Notice</u> .</p>	
<p>Fastener Tightening Specifications: Refer to <u>Fastener Tightening Specifications</u>. Preliminary Procedure: Remove the transfer case shield. Refer to <u>Transfer Case Shield Replacement</u>.</p>	
<p>1</p>	<p>Sensor, Speed Tip: Disconnect the electrical connector. Tighten: 17 N.m (13 lb ft)</p>

TRANSFER CASE OUTPUT SHAFT SEAL REPLACEMENT - FRONT

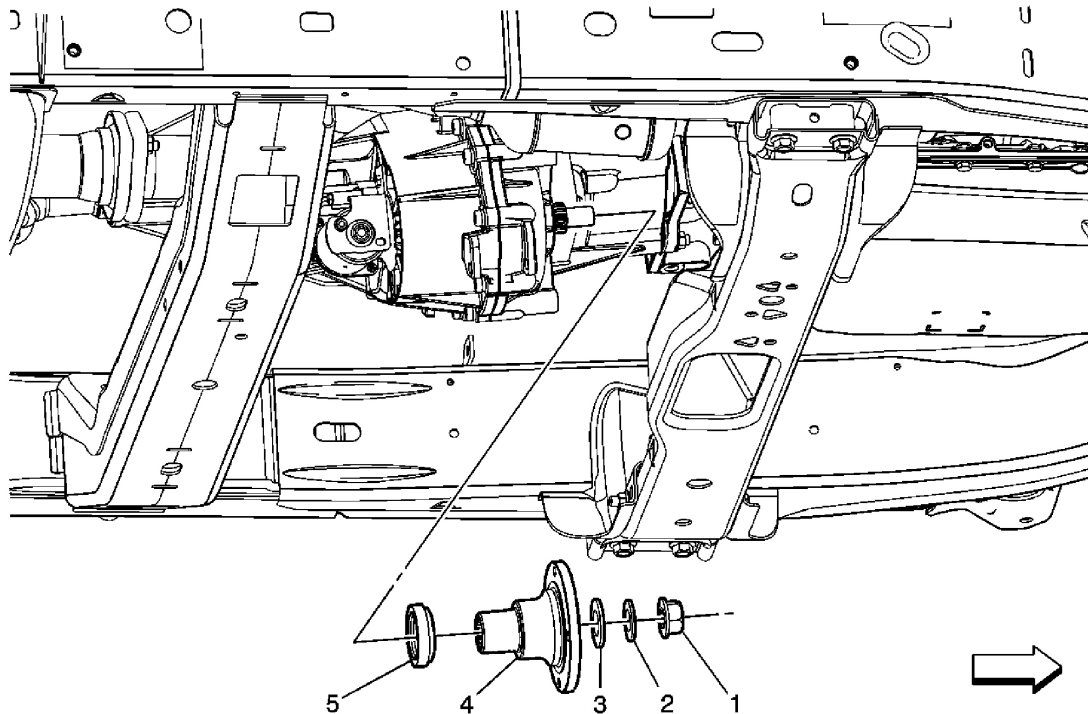

Fig. 18: Transfer Case Output Shaft Seal Replacement - Front
Courtesy of GENERAL MOTORS CORP.

Transfer Case Output Shaft Seal Replacement - Front

Callout	Component Name

NOTE:

Refer to Fastener Notice .

Fastener Tightening Specifications: Refer to Fastener Tightening Specifications.

Preliminary Procedure

1. Raise the vehicle. Refer to Lifting and Jacking the Vehicle .
2. Remove the front propeller shaft. Refer to Front Propeller Shaft Replacement .

Tools Required

- **J 8614-01** Flange and Pulley Holding Tool
- **J 42738** Front Output Shaft Seal Installer. See Special Tools.

1	Nut, Drive Flange Retaining (Qty: 1) Tip: Using the J 8614-01 , remove the retaining nut. Tighten: 319 N.m (235 lb ft)
2	Washer, Drive Flange (Qty: 1)
3	Seal, Drive Flange Washer (Qty: 1)
4	Flange, Drive Flange
5	Seal, Front Output Shaft Tip: <ol style="list-style-type: none"> 1. Using the appropriate tool, remove the seal. 2. Using the J 42738 , install the Front Output Shaft Seal Installer. See <u>Special Tools</u>.

TRANSFER CASE OUTPUT SHAFT SEAL REPLACEMENT - REAR

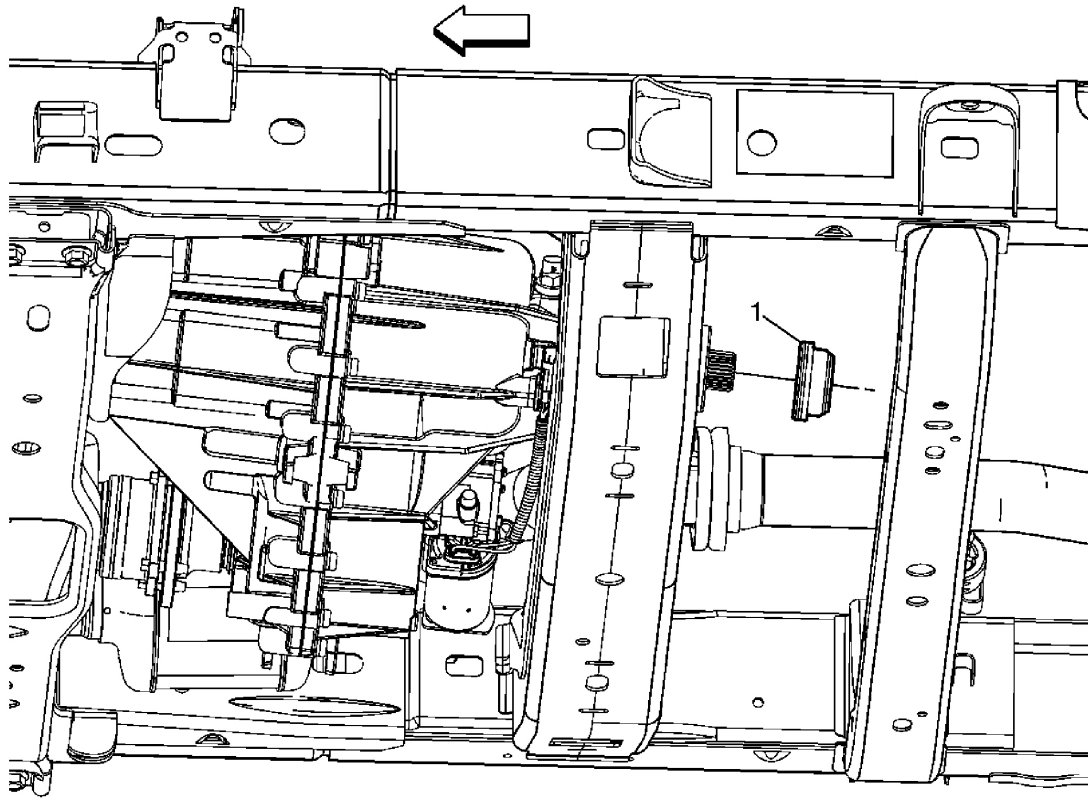

Fig. 19: Transfer Case Output Shaft Seal Replacement - Rear
 Courtesy of GENERAL MOTORS CORP.

Transfer Case Output Shaft Seal Replacement - Rear

Callout	Component Name
<p>Fastener Tightening Specifications: Refer to <u>Fastener Tightening Specifications</u>.</p>	
<p>Preliminary Procedures:</p>	
<p>Remove the rear propeller shaft. Refer to <u>Rear Propeller Shaft Replacement</u> .</p>	
<p>Tools Required</p>	
<ul style="list-style-type: none"> • J 2619-01 Slide Hammer • J 45756 Rear Output Shaft Seal Installer. See <u>Special Tools</u>. • J 45278 Seal Remover. See <u>Special Tools</u>. 	
<p>1</p>	<p>Rear Output Shaft Seal Tip:</p> <ol style="list-style-type: none"> 1. Using the J 2619-01 and J 45756 , remove the seal. See <u>Special Tools</u>.

2. Using the **J 45278** , install the seal. See **Special Tools**.

TRANSFER CASE ASSEMBLY REPLACEMENT

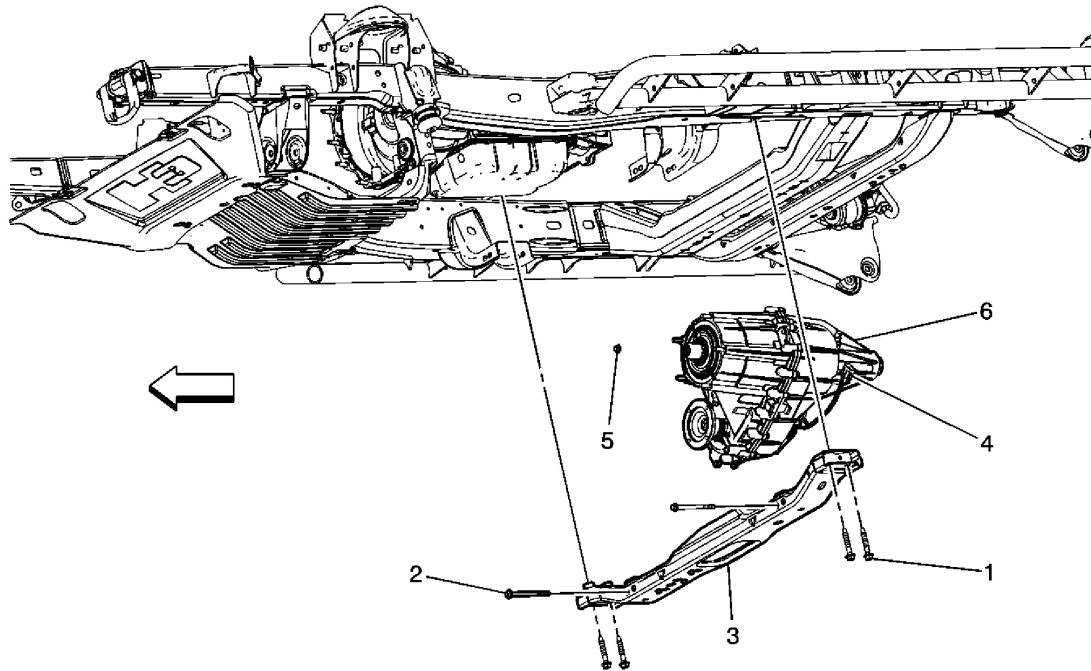

Fig. 20: Transfer Case Assembly Replacement
 Courtesy of GENERAL MOTORS CORP.

Transfer Case Assembly Replacement

Callout	Component Name
Preliminary Procedures	
1. Drain the transfer case. Refer to <u>Transfer Case Fluid Replacement</u> . 2. Remove the front propeller shaft. Refer to <u>Front Propeller Shaft Replacement</u> . 3. Remove the rear propeller shaft. Refer to <u>Rear Propeller Shaft Replacement</u> . 4. Remove the transfer case encoder motor. Refer to cell <u>Transfer Case Motor/Encoder Replacement</u> .	
1	Crossmember Bolt (Qty: 4) NOTE: Refer to <u>Fastener Notice</u> .

2007 Hummer H3

2007 TRANSMISSION Transfer Case - BW 4493/4494 - H3

	<p>Tip: Support the transmission assembly.</p> <p>Tighten: 50 N.m (37 lb ft)</p>
2	<p>Crossmember to Frame Bolt (Qty: 2)</p> <p>Tighten: 100 N.m (74 lb ft)</p>
3	<p>Transfer Case Crossmember</p> <p>Tip: Support the transfer case with a transmission jack.</p>
4	<p>Transfer Case Electrical Connector</p> <p>Tip: Disconnect transfer case electrical connector.</p>
5	<p>Transfer Case to Transmission Nut (Qty: 5)</p> <p>Tighten: 50 N.m (37 lb ft)</p>
6	<p>Transfer Assembly Case</p> <p>Tip: It may be necessary to tip the front of the transfer case downward to remove the transfer case from the vehicle.</p>

TRANSFER CASE INPUT SHAFT SEAL REPLACEMENT

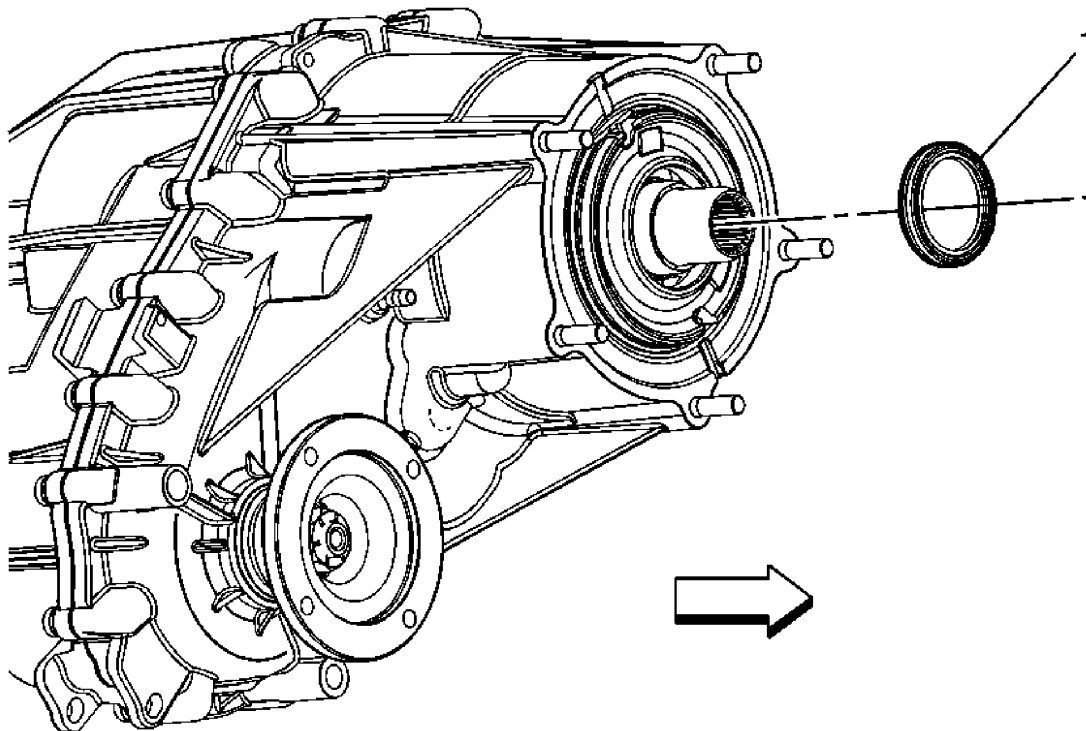

Fig. 21: Transfer Case Input Shaft Seal Replacement
 Courtesy of GENERAL MOTORS CORP.

Transfer Case Input Shaft Seal Replacement

Callout	Component Name
Fastener Tightening Specifications: Refer to <u>Fastener Tightening Specifications</u> .	
Preliminary Procedure:	
Remove the transfer case assembly. Refer to <u>Transfer Case Assembly Replacement</u> .	
Tools Required:	
J 42738 Front Output Shaft Seal Installer. See <u>Special Tools</u> .	
1	Seal, Front Input Shaft Seal Tip: <ol style="list-style-type: none"> 1. Using a long flat-bladed screwdriver, remove the seal. 2. Using the J 42738 , install the seal. See <u>Special Tools</u>.

TRANSFER CASE ADAPTER REPLACEMENT

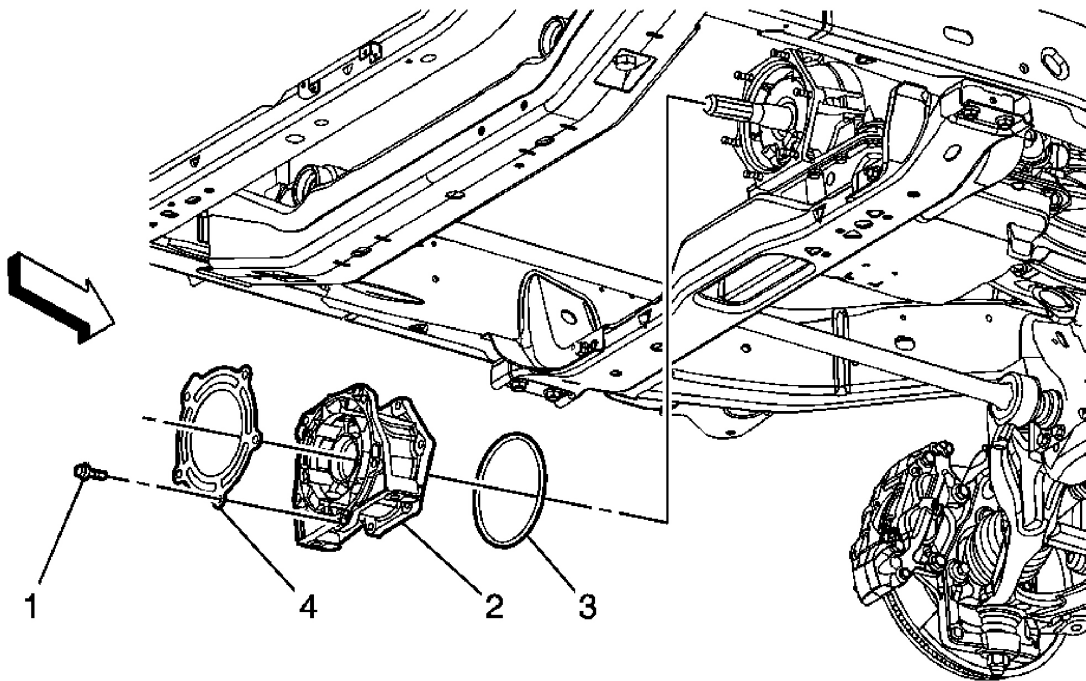

Fig. 22: Transfer Case Adapter Replacement
 Courtesy of GENERAL MOTORS CORP.

Transfer Case Adapter Replacement

2007 Hummer H3

2007 TRANSMISSION Transfer Case - BW 4493/4494 - H3

Callout	Component Name
NOTE: Refer to <u>Fastener Notice</u> .	
Fastener Tightening Specifications: Refer to <u>Fastener Tightening Specifications</u> . Preliminary Procedure: Remove the transfer case. Refer to <u>Transfer Case Assembly Replacement</u> .	
1	Bolt, Transfer Case Adapter (Qty: 6) Tighten: 50 N.m (37 lb ft)
2	Adapter, Transfer Case to Transmission
3	O-ring, Transfer Case Adapter Tip: DO NOT reuse the O-ring. Replace it.
4	Gasket, Transfer Case Adapter Tip: DO NOT reuse the gasket. Replace it.

TRANSFER CASE SHIFT CONTROL SWITCH REPLACEMENT

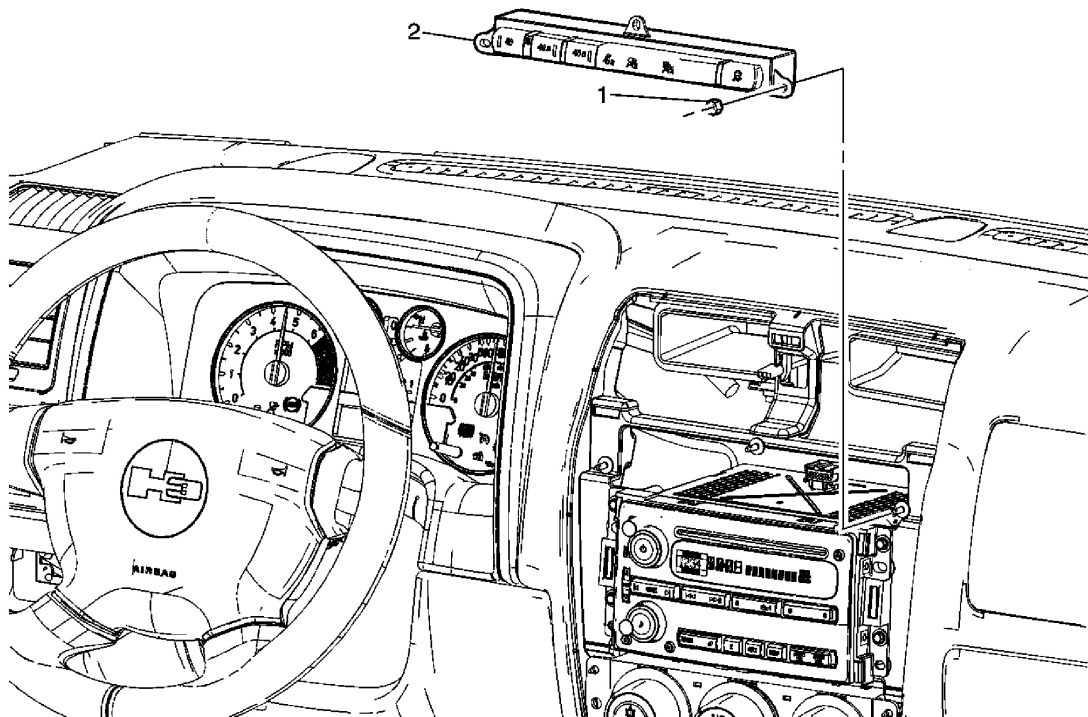

Fig. 23: Transfer Case Shift Control Switch Replacement
Courtesy of GENERAL MOTORS CORP.

2007 Hummer H3

2007 TRANSMISSION Transfer Case - BW 4493/4494 - H3

Transfer Case Shift Control Switch Replacement

Callout	Component View
NOTE: Refer to <u>Fastener Notice</u> .	
Fastener Tightening Specifications: Refer to <u>Fastener Tightening Specifications</u> . Preliminary Procedure: Remove the instrument panel (I/P) center trim panel. Refer to <u>Instrument Panel Center Trim Panel Replacement (Left Hand Drive)</u> or <u>Instrument Panel Center Trim Panel Replacement (Right Hand Drive)</u> .	
1	Control Switch Mounting Nut (Qty: 3) Tip: Disconnect the electrical connector. Tighten: 6 N.m (53 lb in)

REPAIR INSTRUCTIONS - OFF VEHICLE

TRANSFER CASE DISASSEMBLE

Tools Required

- **J 2619-01** Slide Hammer
- **J 3289-20** Holding Fixture
- **J 6125-1B** Slide Hammer with Adapter
- **J 8614-01** Flange and Pulley Holding Tool
- **J 22912-B** Rear Pinion and Axle Bearing Remover
- **J 23129** Universal Seal Remover
- **J 23907** Slide Hammer with Bearing Adapter
- **J 29369-1** Bushing and Bearing Remover
- **J 45278** Seal Remover. See Special Tools.
- **J 45358** Case Spreader. See Special Tools.
- **J 45380** Transfer Case Rear Bushing Remover and Installer. See Special Tools.
- **J 45548** Mainshaft Support Bushing/Bearing Remover. See Special Tools.
- **J 45759** Assembly Fixture. See Special Tools.

Disassembly Procedure

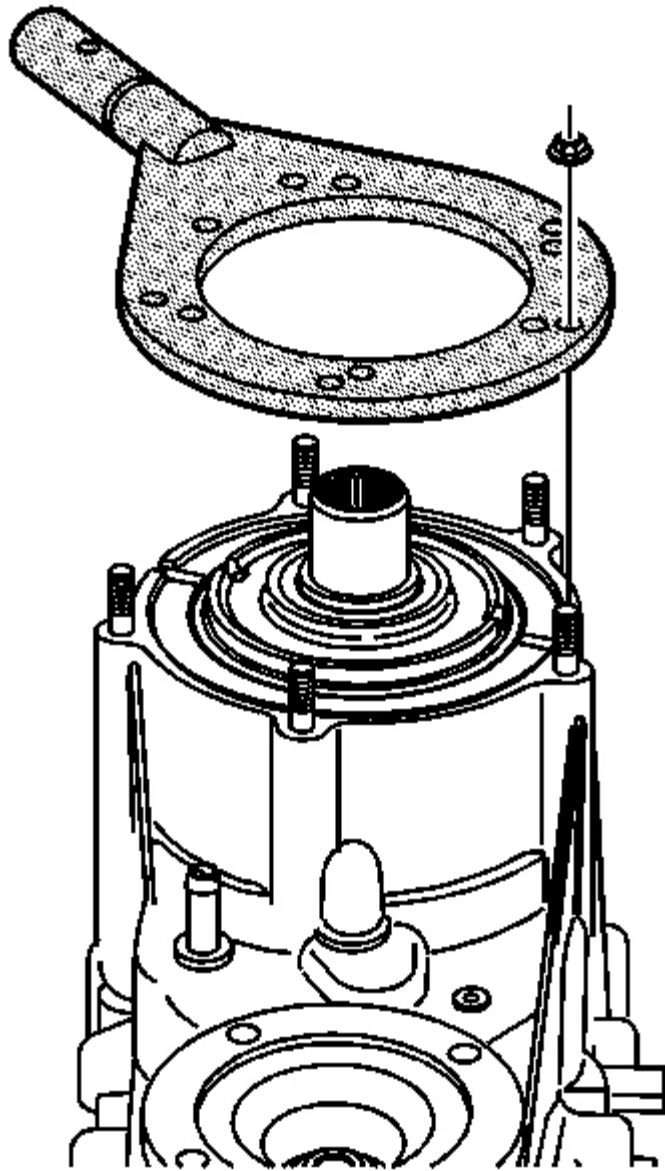

Fig. 24: Identifying Assembly Fixture J 45759
Courtesy of GENERAL MOTORS CORP.

1. Using the adapter studs, attach the **J 45759** to the transfer case. See **Special Tools**. All of the transfer case disassembly procedures can be performed with the case mounted to the **J**

45759 . See Special Tools.

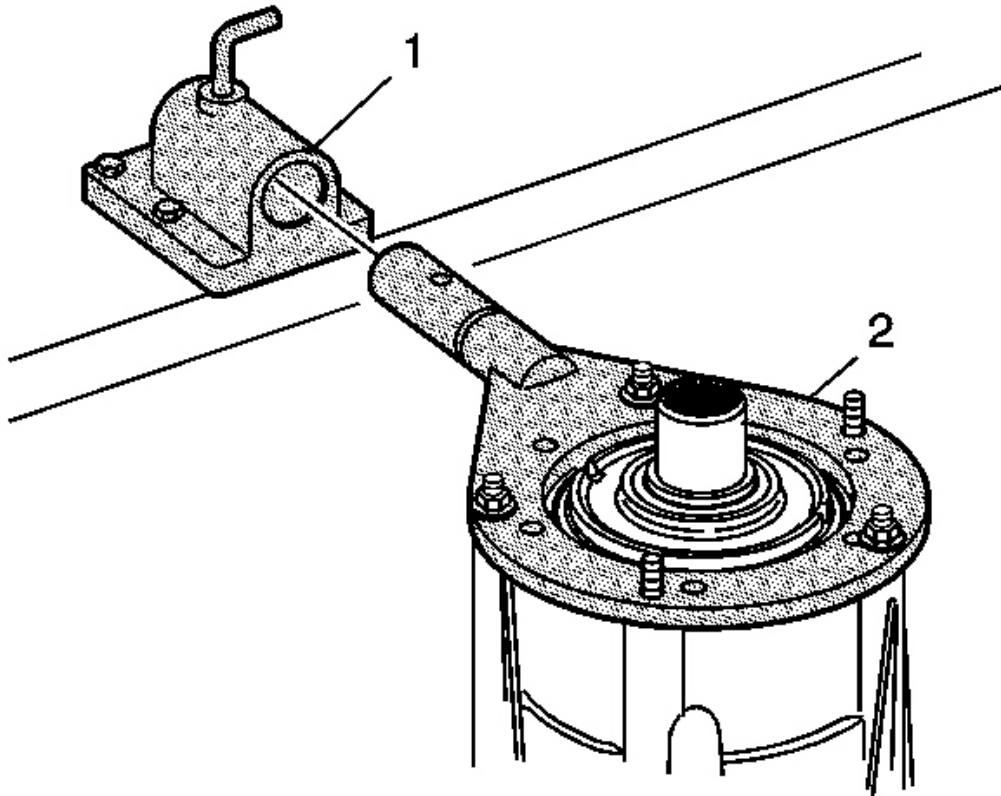

Fig. 25: View Of J 3289-20 Mounted TO Workbench
Courtesy of GENERAL MOTORS CORP.

2. Mount the **J 3289-20** (1) to a sturdy workbench.
3. Install the **J 45759** (2) into **J 3289-20** (1) and secure with pivot pin. See Special Tools.

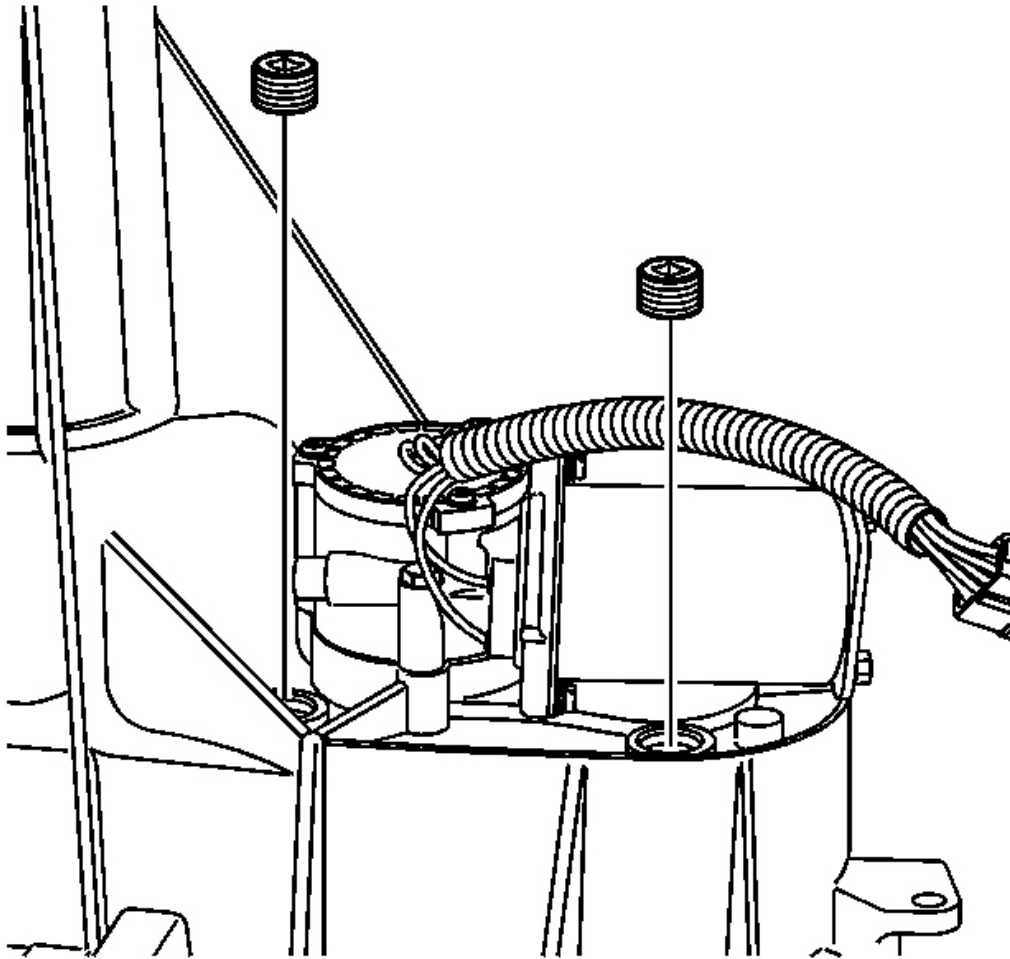

Fig. 26: Locating Drain Plug And The Fill Plug
Courtesy of GENERAL MOTORS CORP.

4. Remove the drain plug and the fill plug. Ensure all transfer case fluid is drained out of the transfer case.

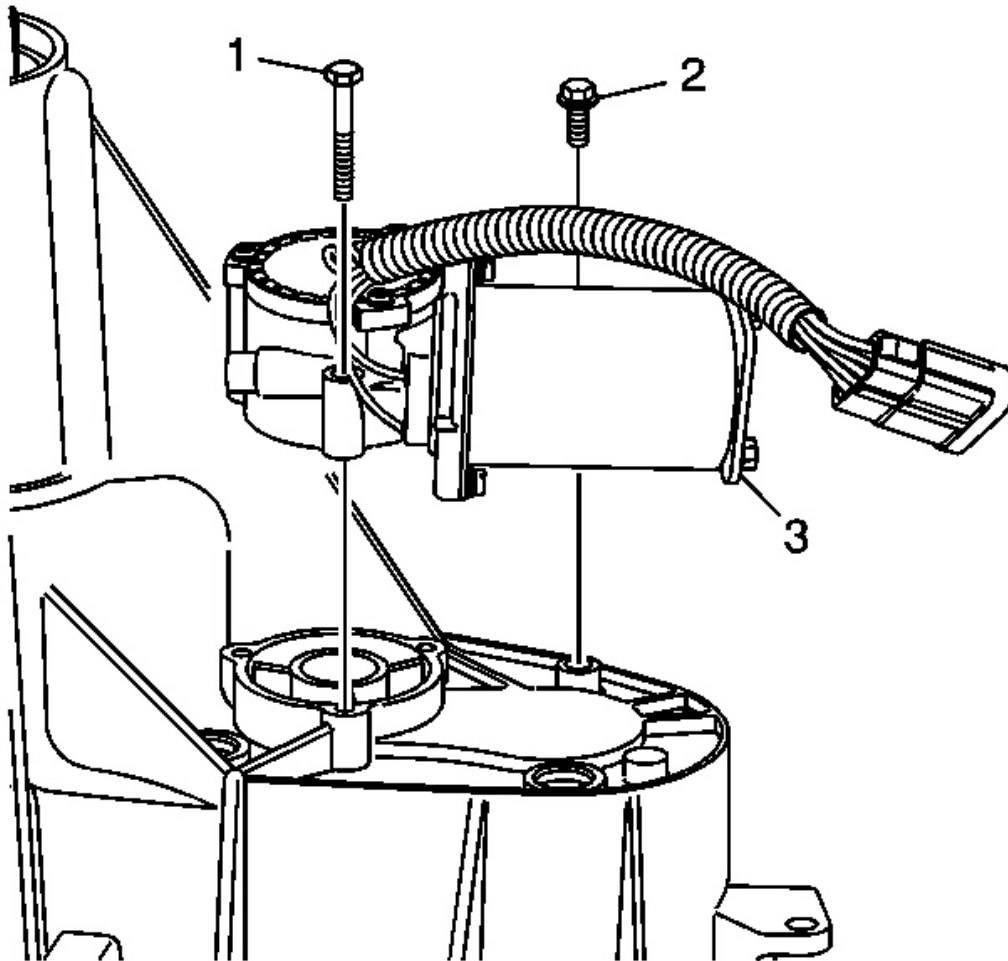

Fig. 27: Locating Encoder Motor, Bracket Bolts And Mounting Bolts
Courtesy of GENERAL MOTORS CORP.

5. Remove the encoder motor bracket bolt (2).
6. Remove the encoder motor mounting bolts (1).
7. Remove the encoder motor assembly (3).

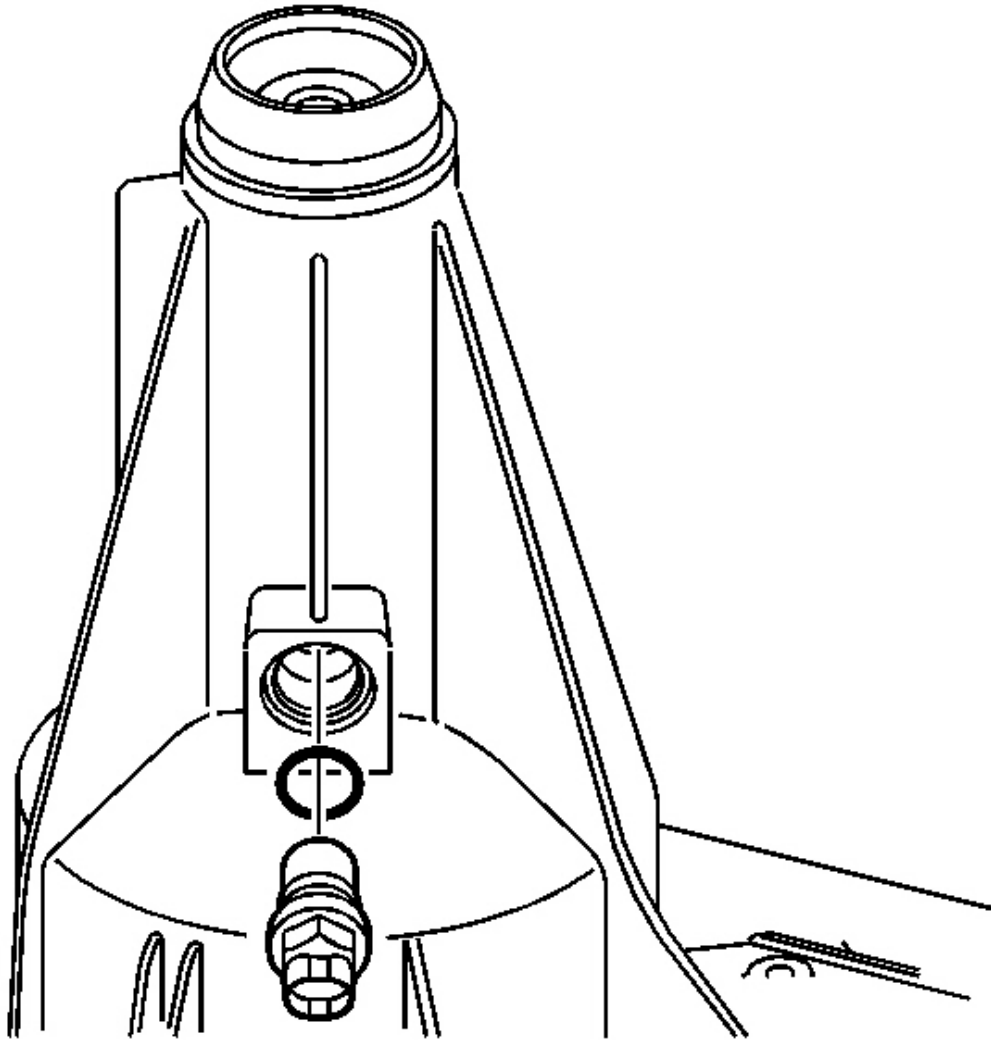

Fig. 28: View Of Vehicle Speed Sensor (VSS) & O-Ring Seal
Courtesy of GENERAL MOTORS CORP.

8. Remove the rear vehicle speed sensor (VSS) and the O-ring seal.

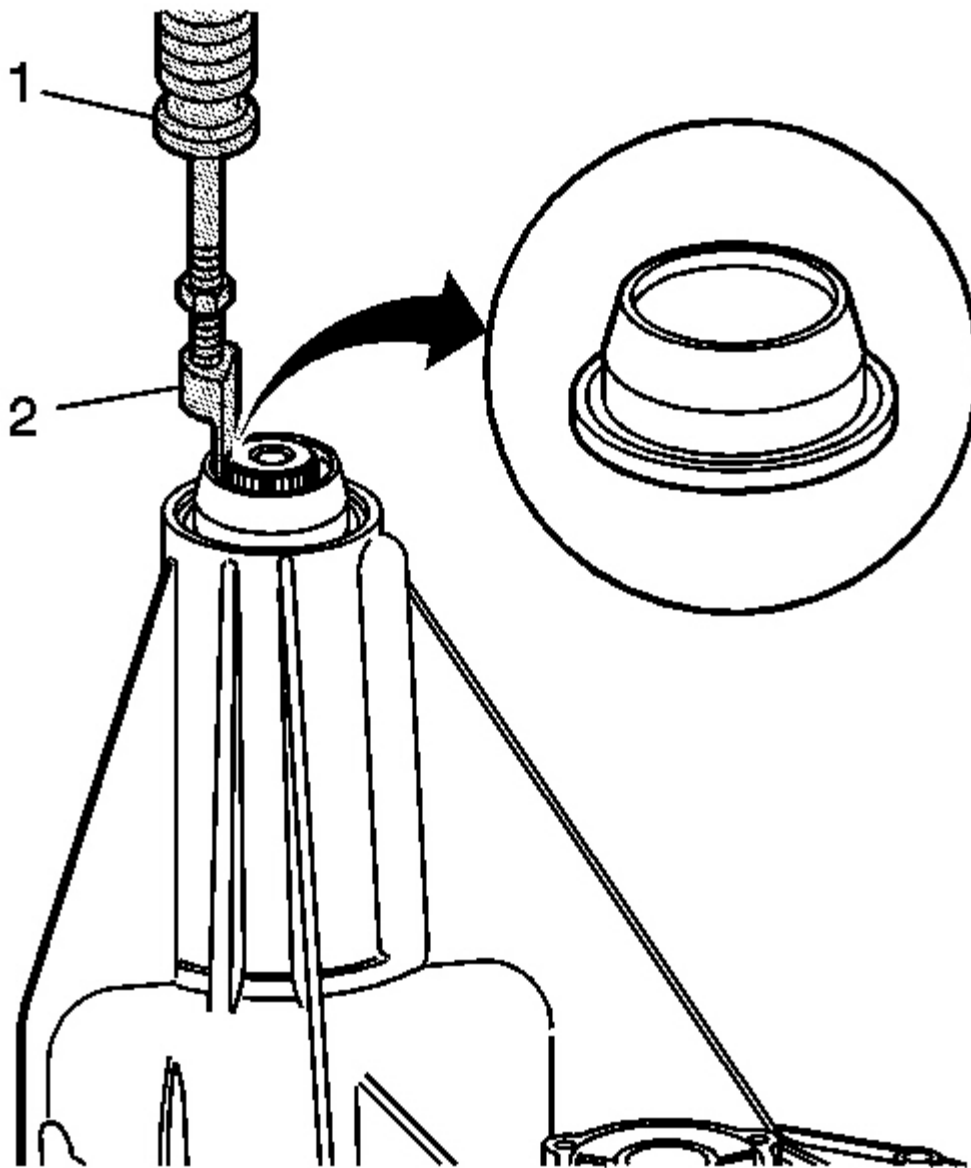

Fig. 29: Removing The Rear Output Shaft Seal
Courtesy of GENERAL MOTORS CORP.

NOTE: Refer to Transfer Case Seal Removal Notice .

- Using the **J 2619-01** (1) and the **J 45278** (2), remove the rear output shaft seal. See **Special Tools**.

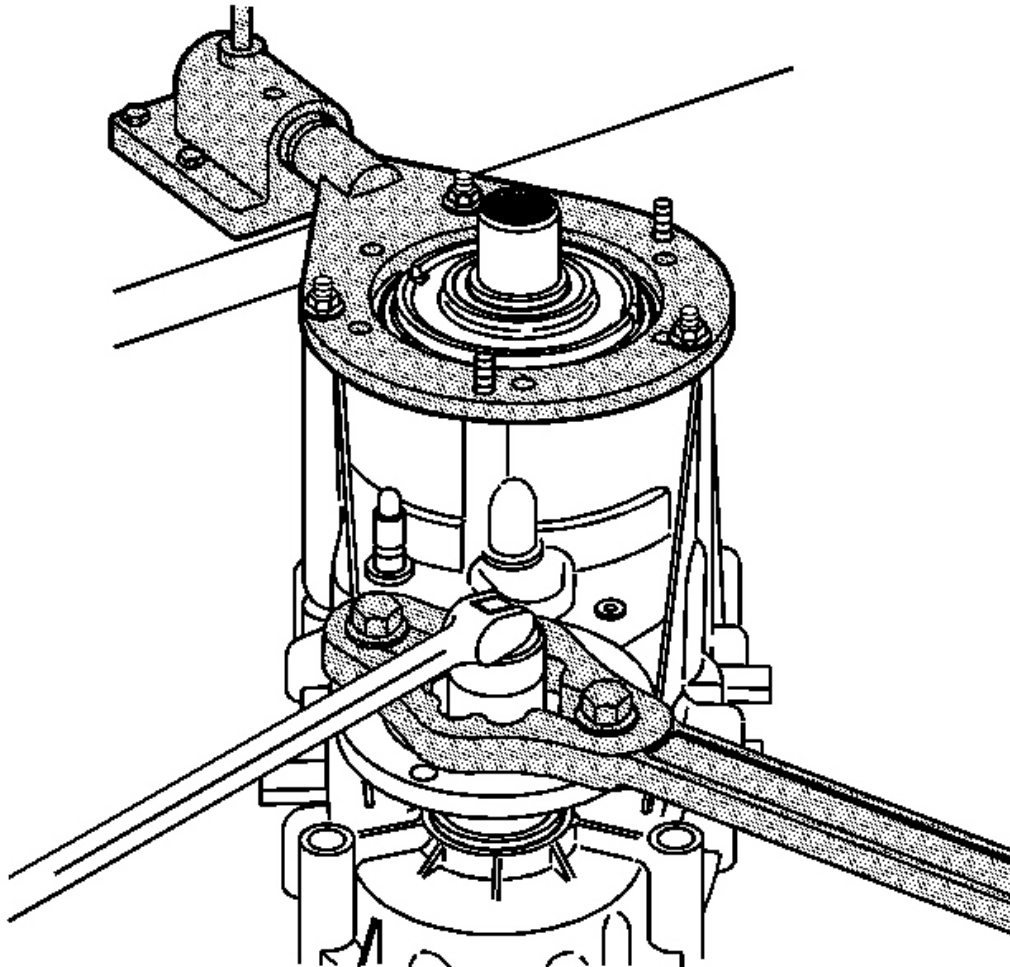

Fig. 30: Loosening Front Output Shaft Flange Nut
Courtesy of GENERAL MOTORS CORP.

- Install the **J 8614-01** to the front output shaft flange.
- Hold the **J 8614-01** and loosen the front output shaft flange nut.

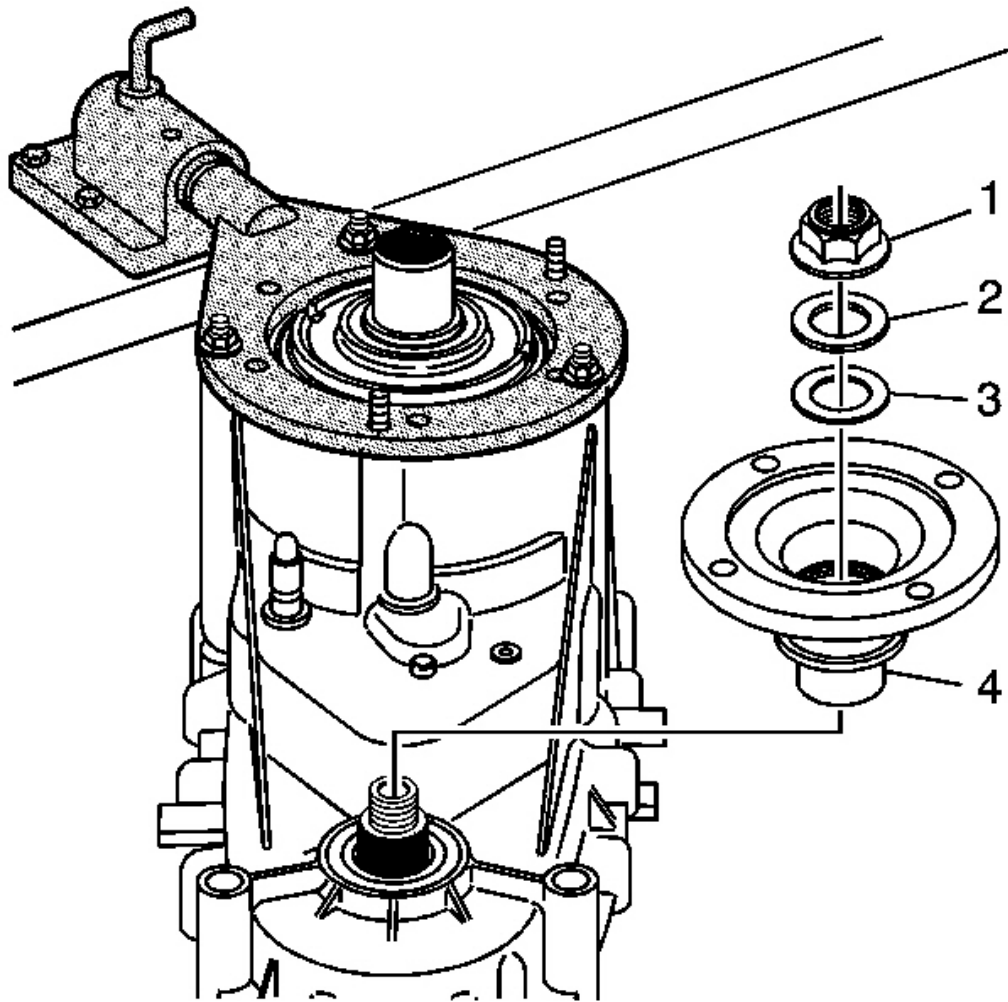

Fig. 31: Exploded View OF Output Flange And Components
Courtesy of GENERAL MOTORS CORP.

12. Remove the front output shaft flange nut (1).
13. Remove the front output shaft flange washer (2).
14. Remove the front output shaft flange seal (3).
15. Remove the front output shaft flange (4).

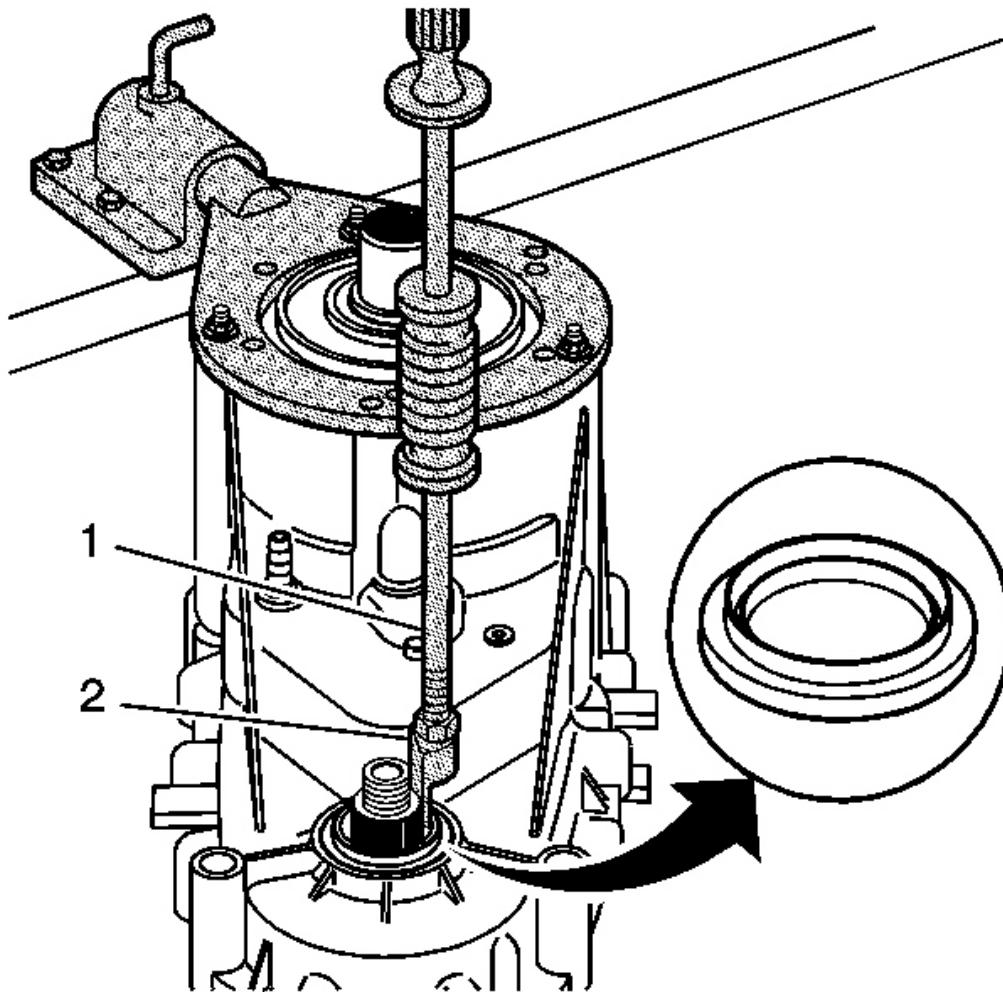

Fig. 32: Removing The Front Output Shaft Seal
Courtesy of GENERAL MOTORS CORP.

16. Using the **J 6125-1B** (1) and the **J 23129** (2), remove the front output shaft seal.

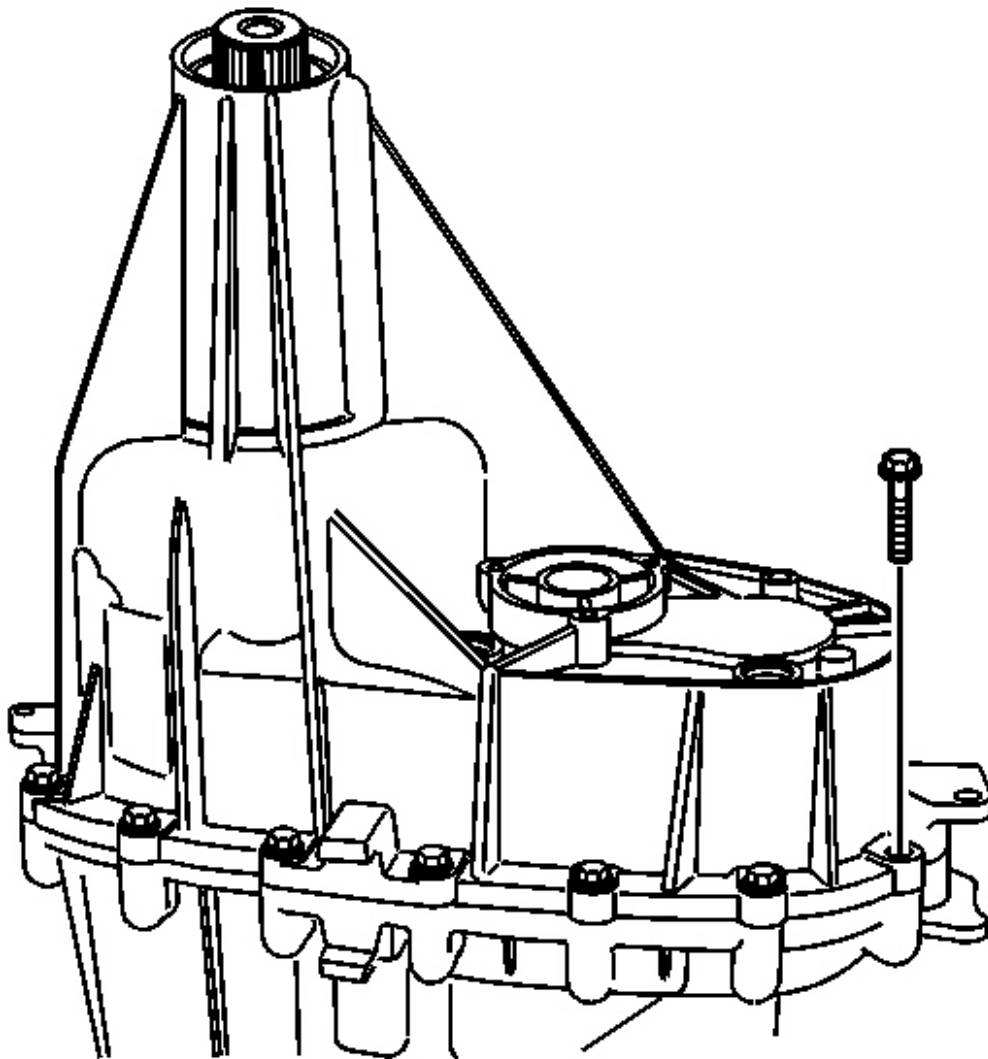

Fig. 33: Identifying Transfer Case Retaining Bolts
Courtesy of GENERAL MOTORS CORP.

17. Remove the transfer case retaining bolts and washers.

Mark the location of the brackets.

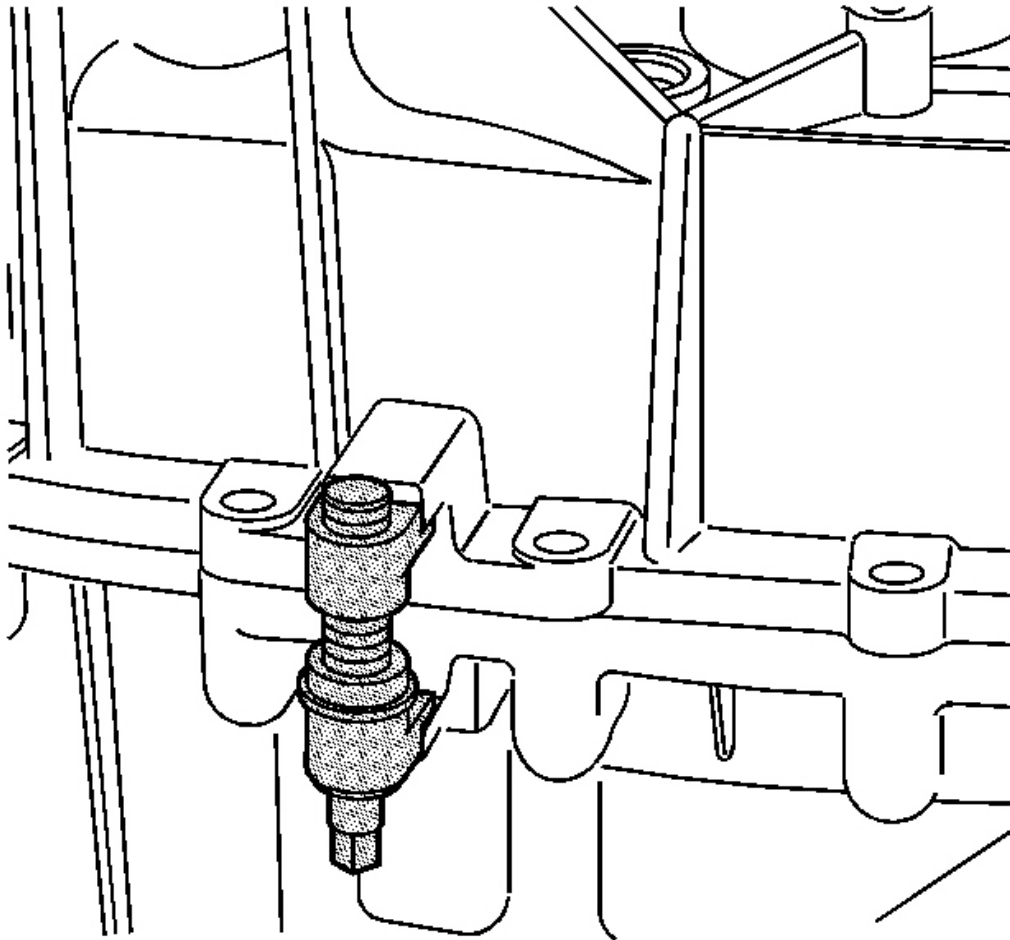

Fig. 34: Identifying J 45358 Case Spreader
Courtesy of GENERAL MOTORS CORP.

NOTE: Refer to Machined Surface Damage Notice .

18. Using the **J 45358** between the tabs on the case halves, shear the sealer that is holding the case halves together. See Special Tools.
19. Using pry bars at each side of the case, remove the case from the locating pins.

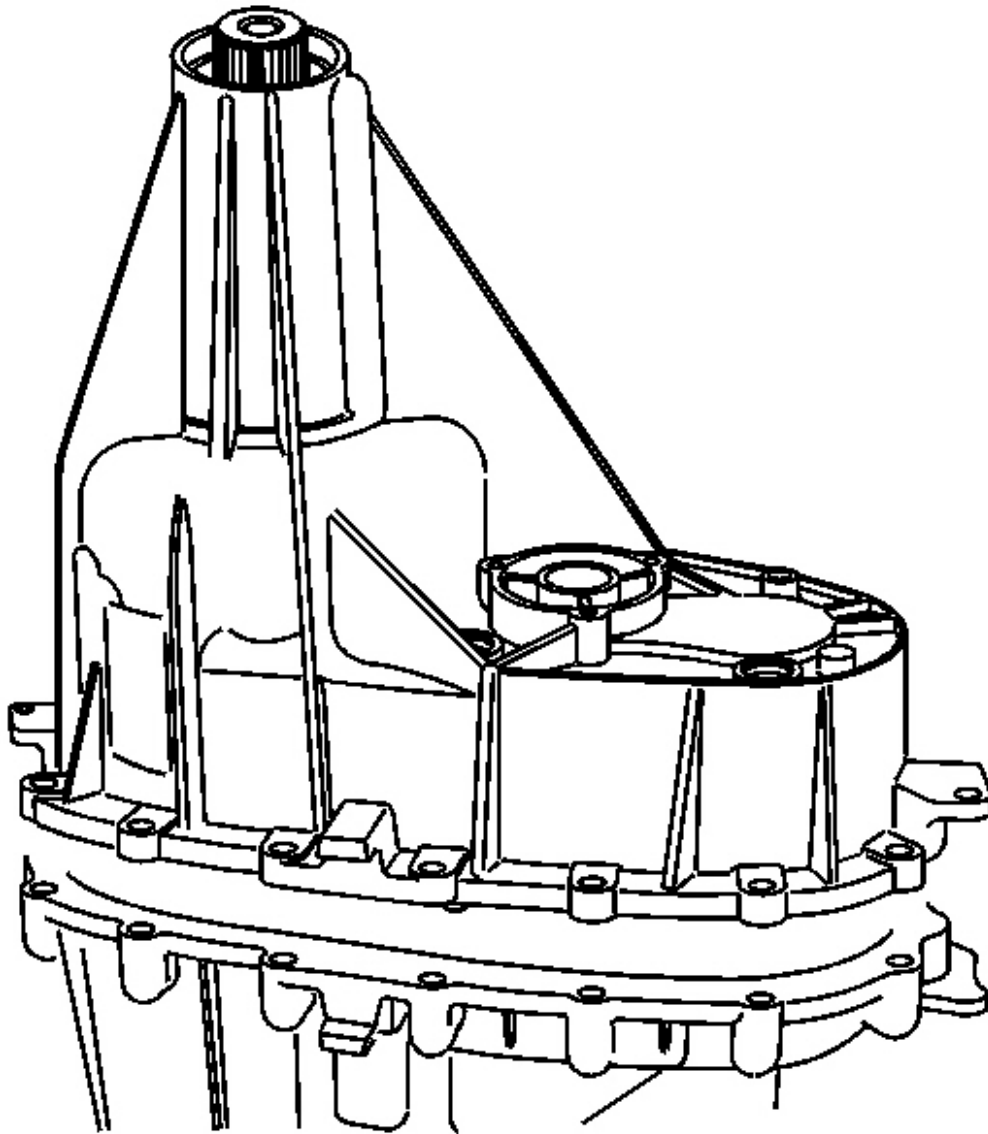

Fig. 35: View Of Rear Case Half & Front Case Half
Courtesy of GENERAL MOTORS CORP.

20. Remove the rear case half from the front case half. The rear output shaft is removed with the rear case half.

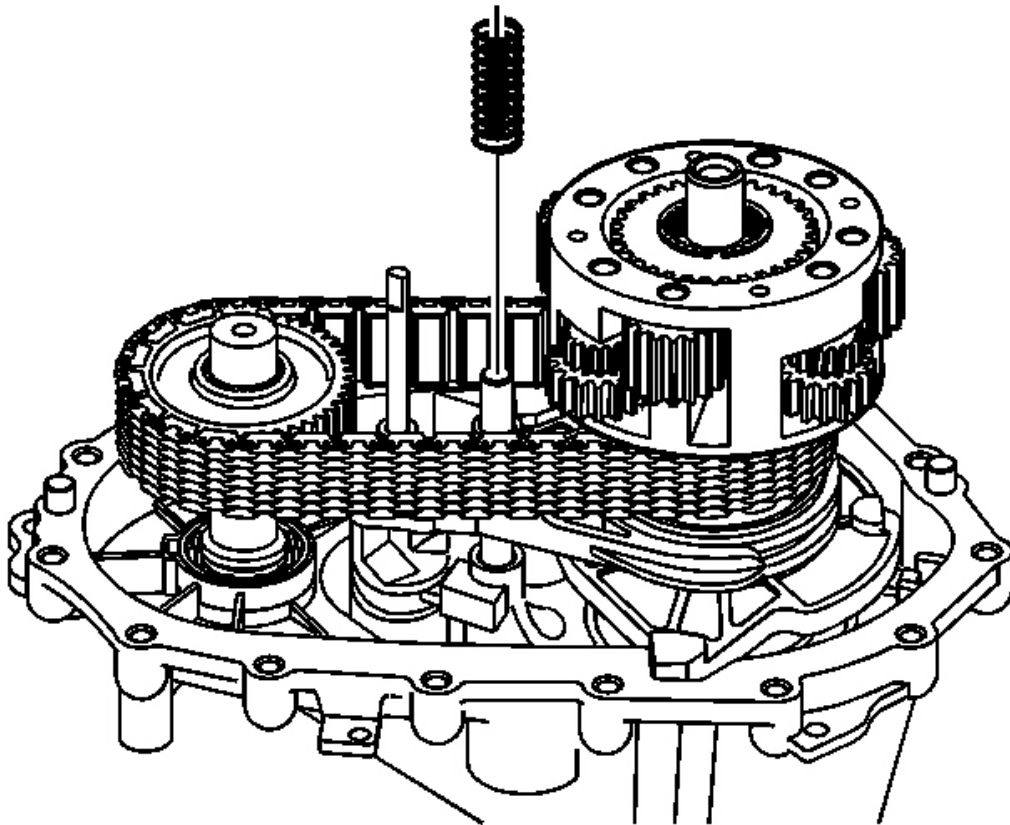

Fig. 36: Identifying Shift Fork Shaft Spring
Courtesy of GENERAL MOTORS CORP.

21. Remove the shift fork shaft spring.

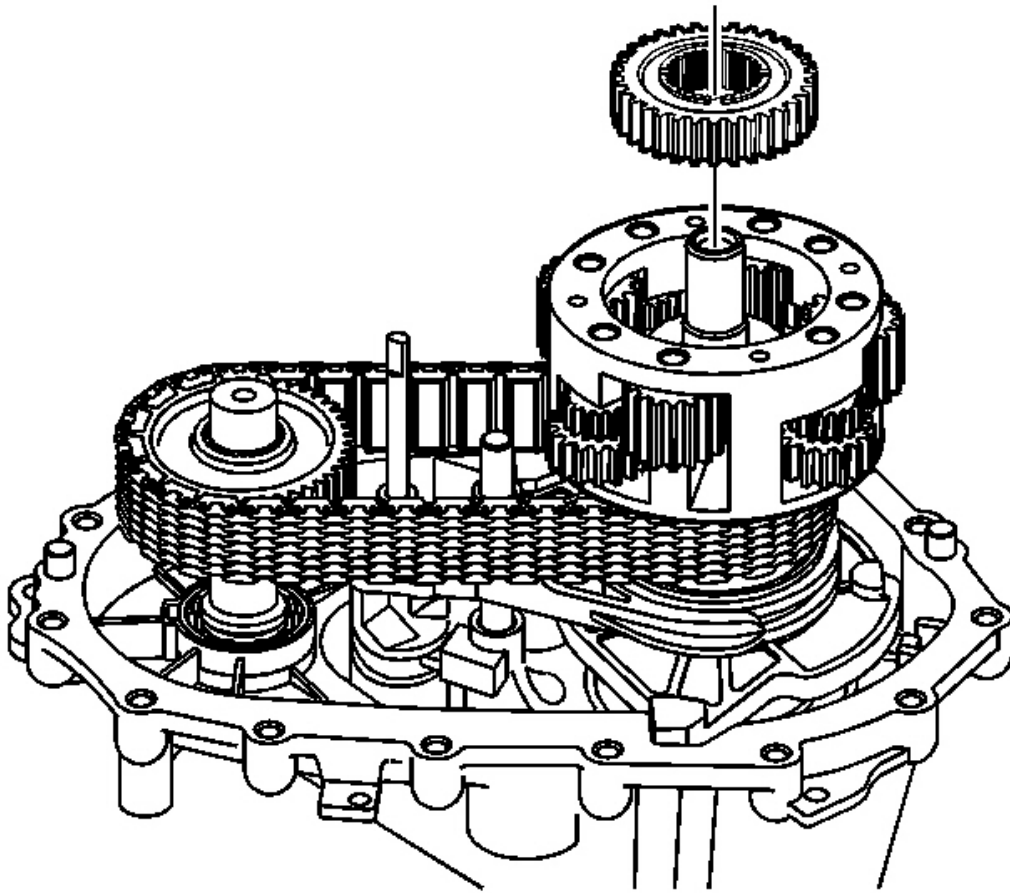

Fig. 37: Removing/Installing Rear Output Sun Gear
Courtesy of GENERAL MOTORS CORP.

22. Remove the rear output sun gear.

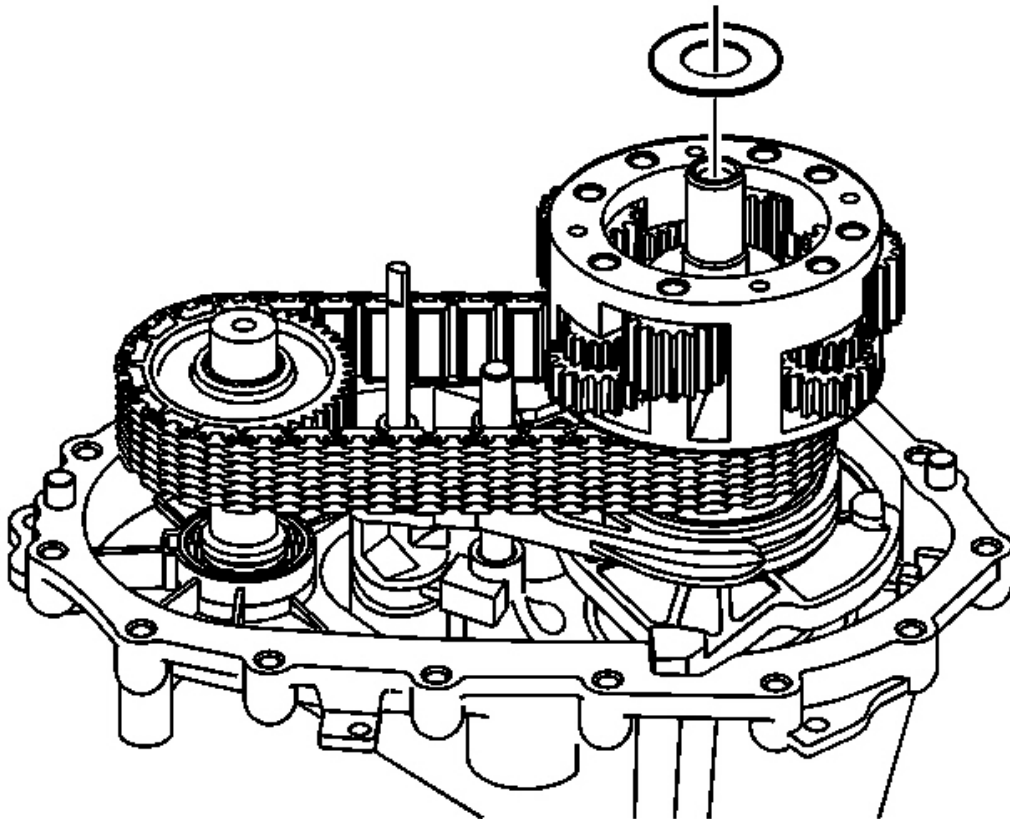

Fig. 38: Removing/Installing Rear Output Shaft Thrust Washer
Courtesy of GENERAL MOTORS CORP.

23. Remove the rear output shaft thrust washer.

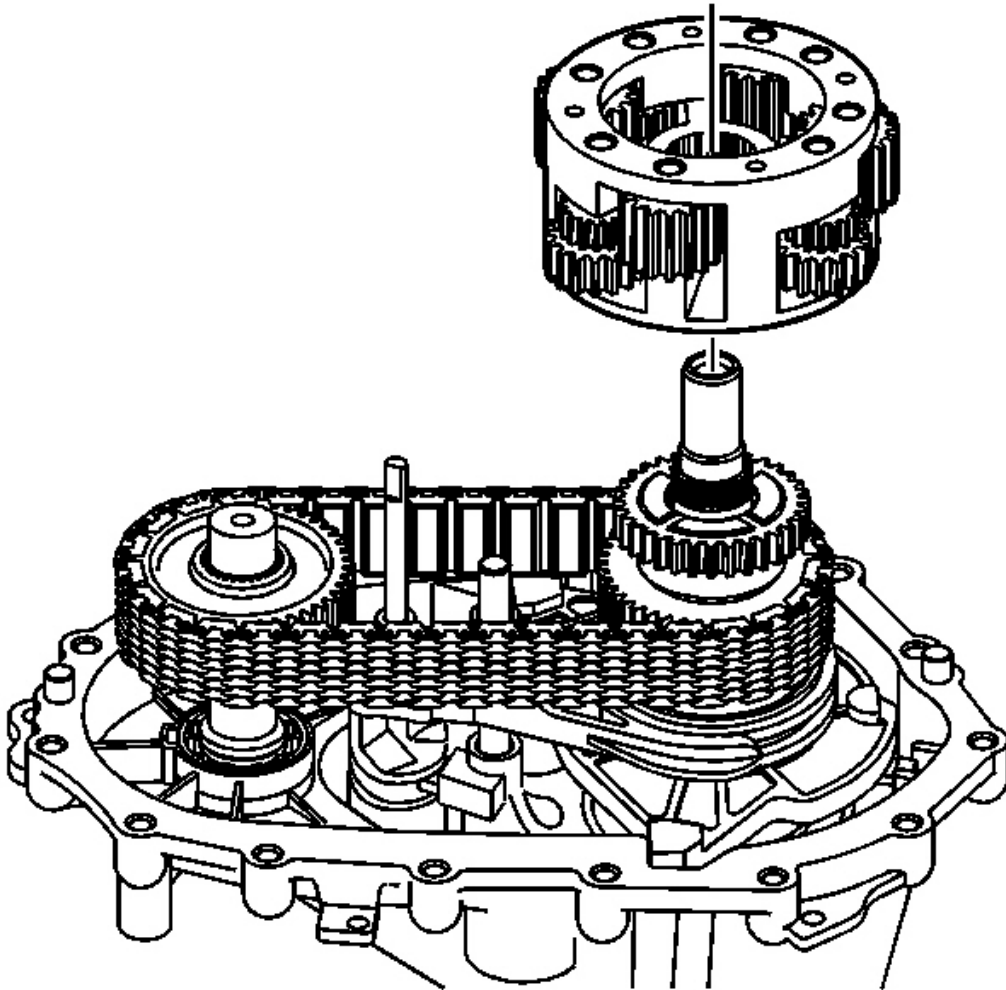

Fig. 39: Identifying Planetary Differential Assembly
Courtesy of GENERAL MOTORS CORP.

24. Remove the planetary differential assembly.

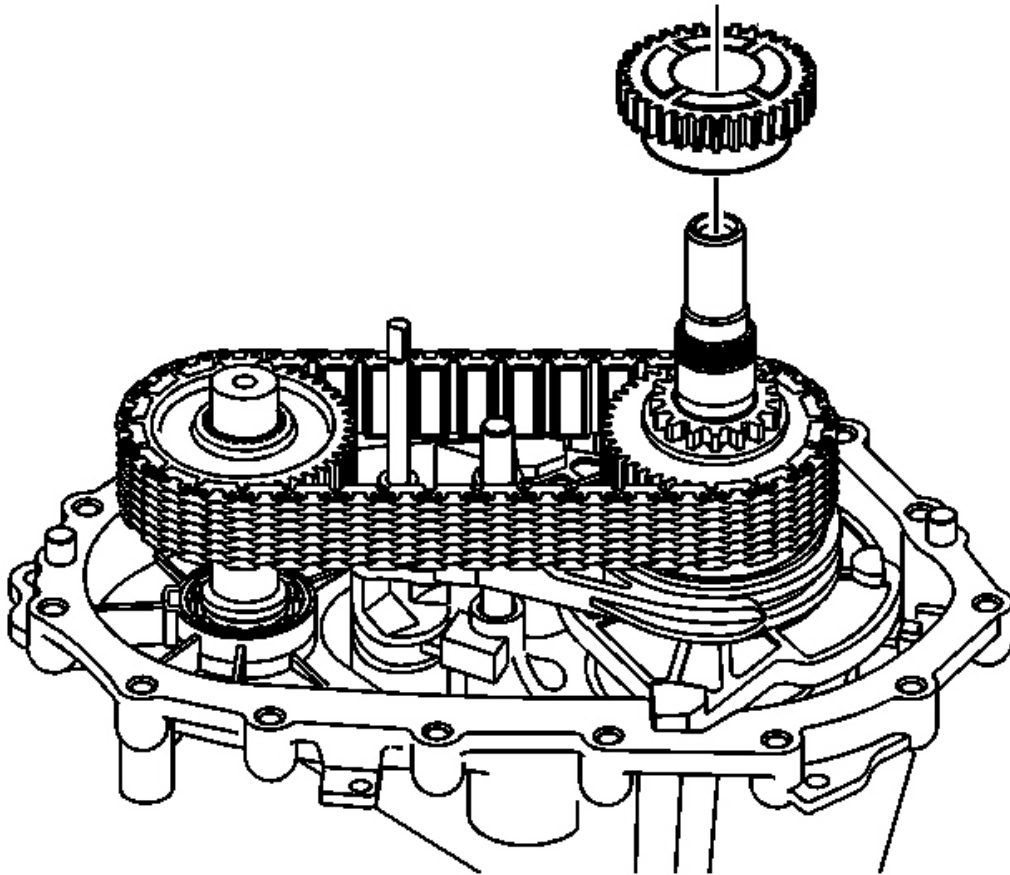

Fig. 40: Identifying Front Output Sun Gear
Courtesy of GENERAL MOTORS CORP.

25. Remove the front output sun gear.

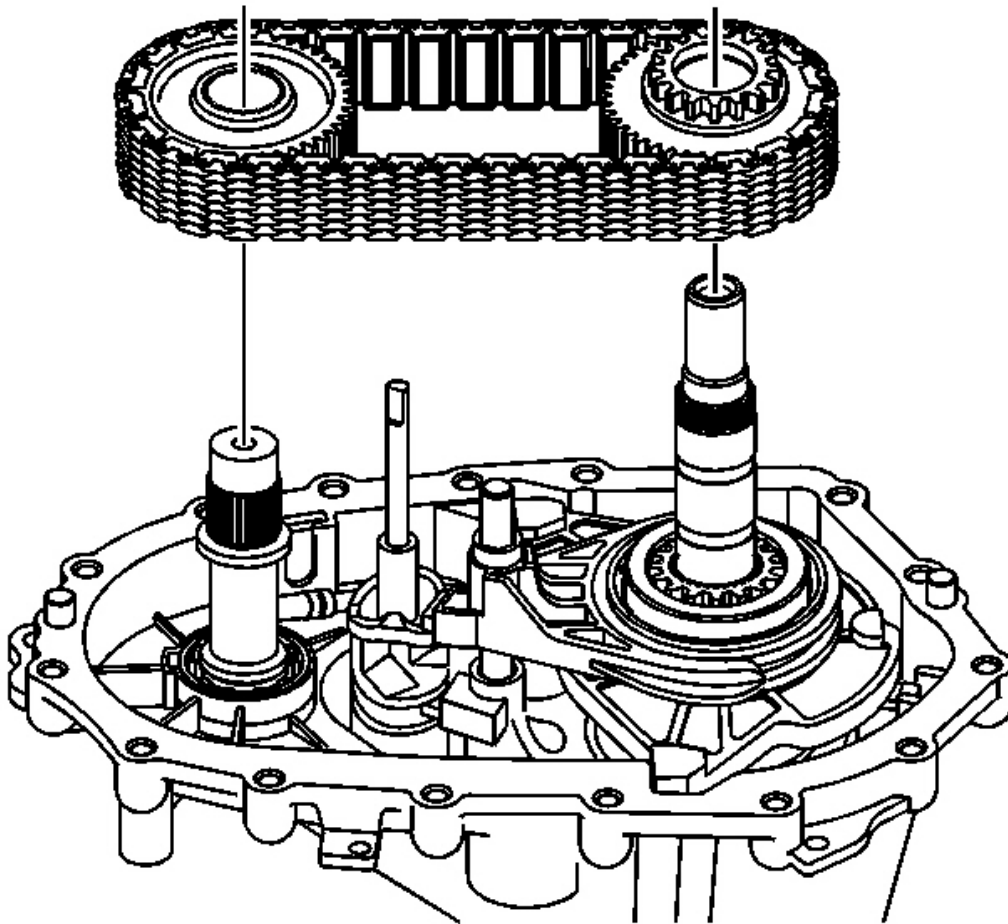

Fig. 41: View Of Chain With Drive Sprocket & Driven Sprocket
Courtesy of GENERAL MOTORS CORP.

IMPORTANT: If the chain and sprockets are to be used again, mark the relationship of the chain to the sprockets in order to mark the wear patterns.

26. Remove the chain with the drive sprocket and driven sprocket.

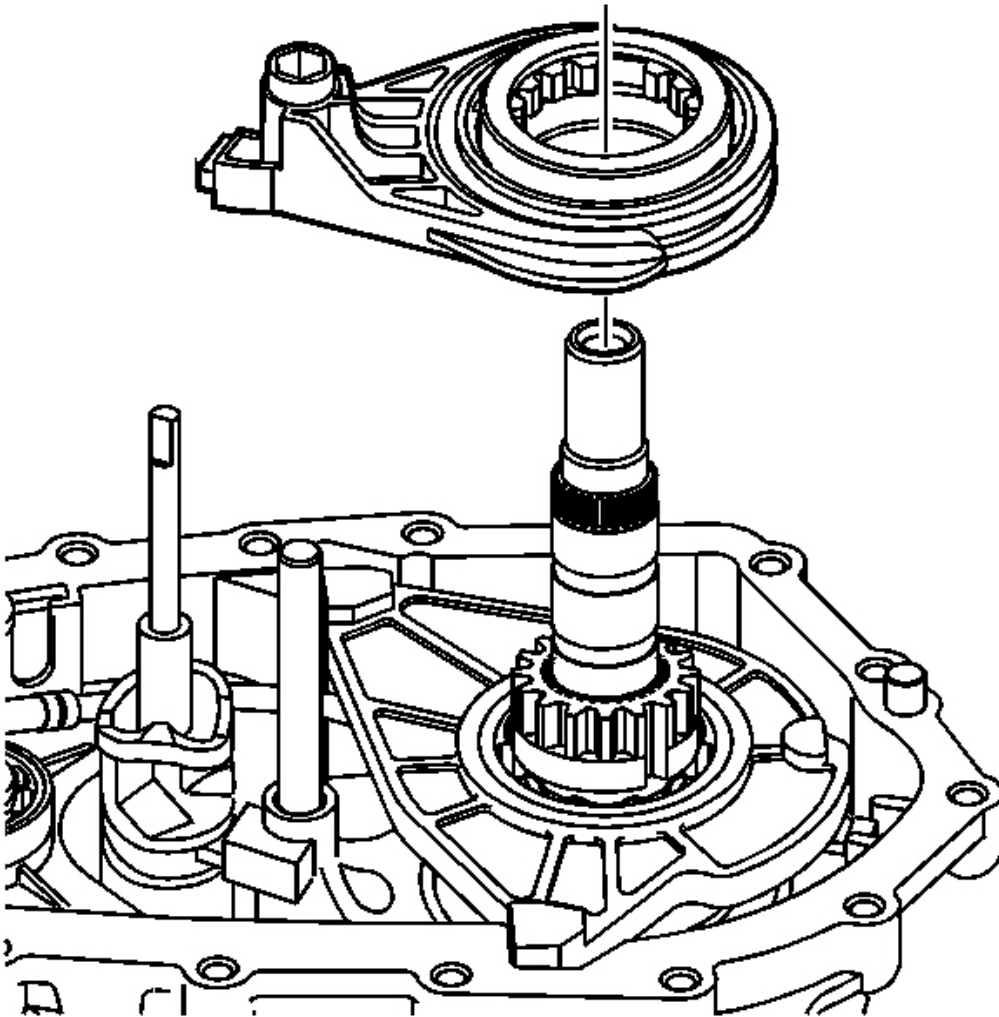

Fig. 42: View Of Lockup Mode Shift Fork & Lockup Shift Collar Assembly
Courtesy of GENERAL MOTORS CORP.

27. Remove the lockup shift collar assembly and lockup mode shift fork.

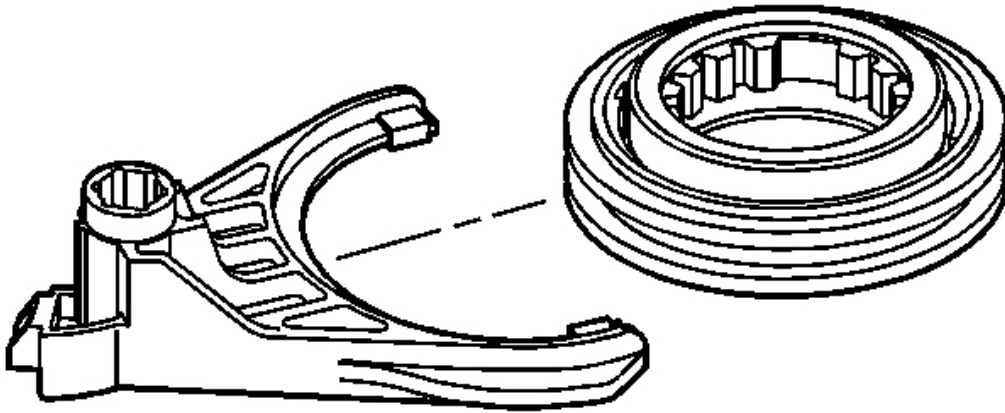

Fig. 43: Identifying Lockup Mode Shift Fork
Courtesy of GENERAL MOTORS CORP.

28. Remove the lockup mode shift fork from the lockup shift collar assembly.

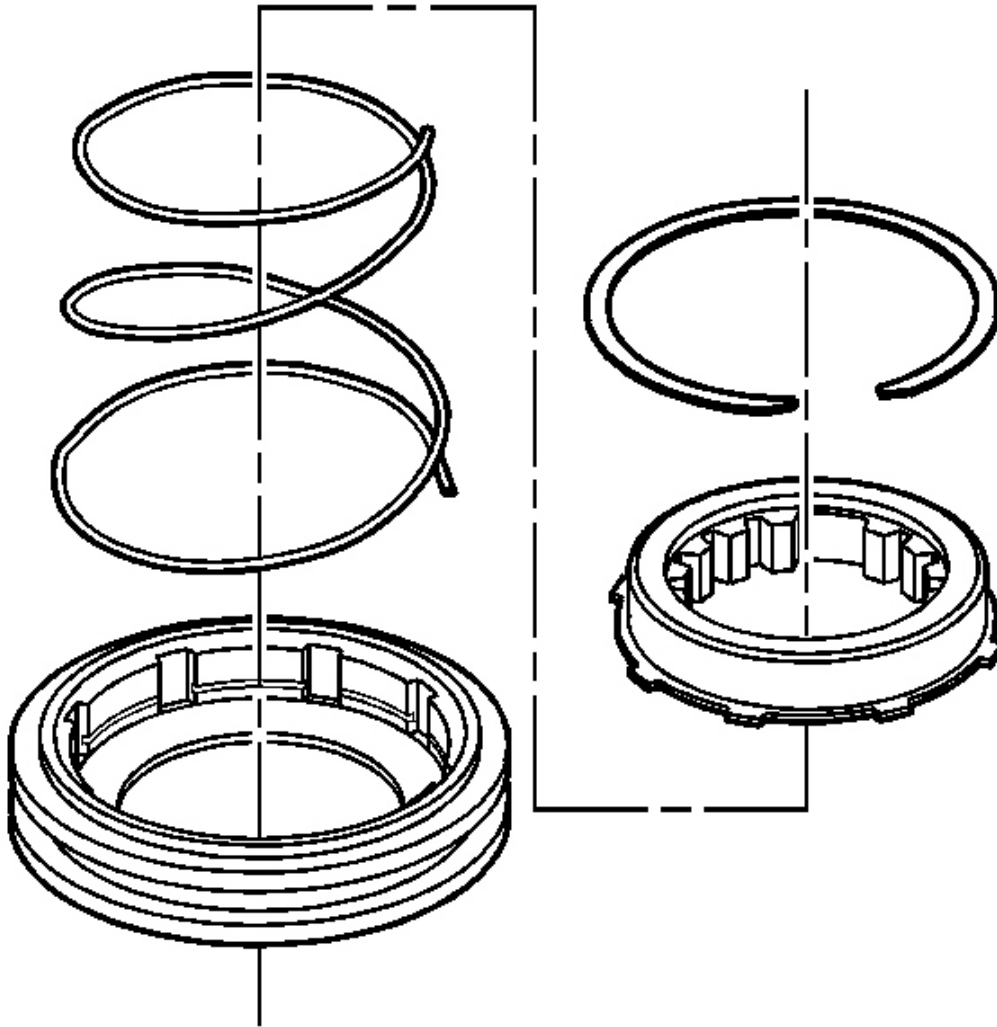

Fig. 44: View Of Lockup Shift Collar Assembly
Courtesy of GENERAL MOTORS CORP.

29. Disassemble the lockup shift collar assembly, if necessary.
 1. Remove the retainer ring from the sleeve.
 2. Remove the hub.
 3. Remove the spring.

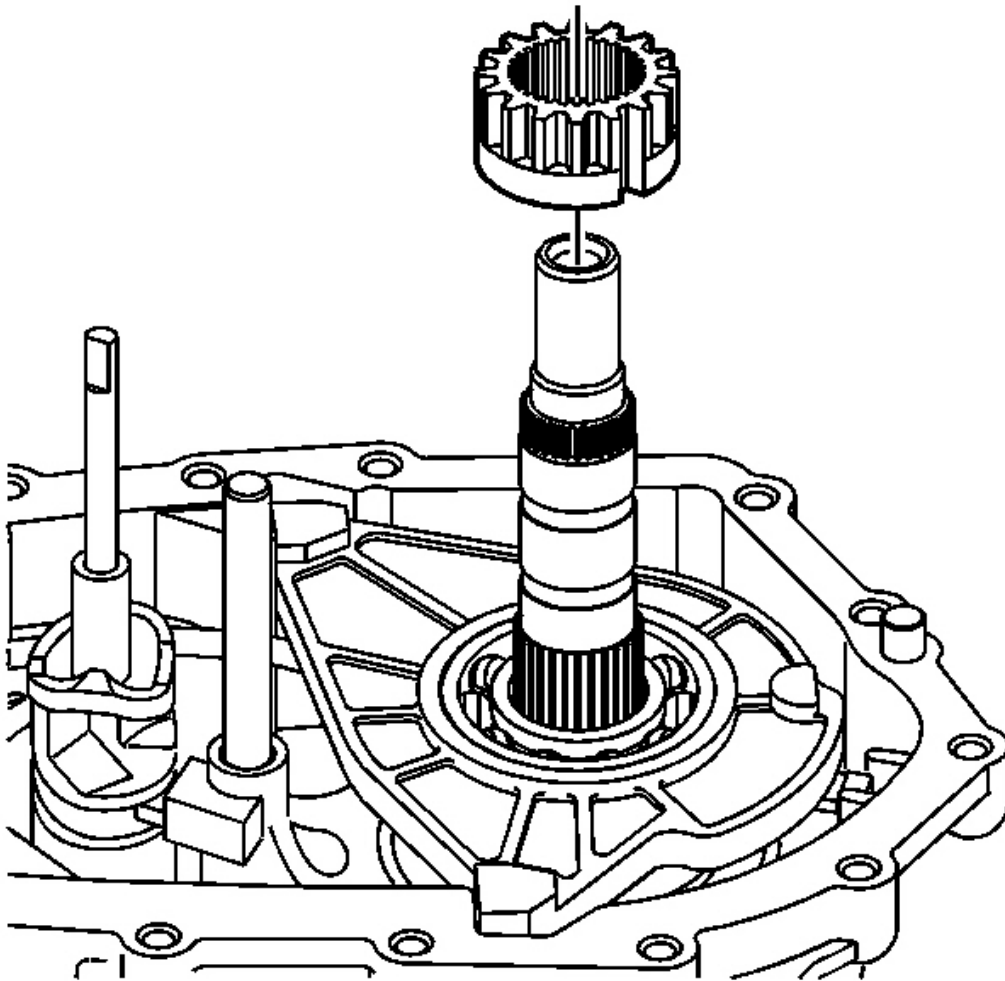

Fig. 45: Identifying Inner Lockup Hub
Courtesy of GENERAL MOTORS CORP.

30. Remove the inner lockup hub.

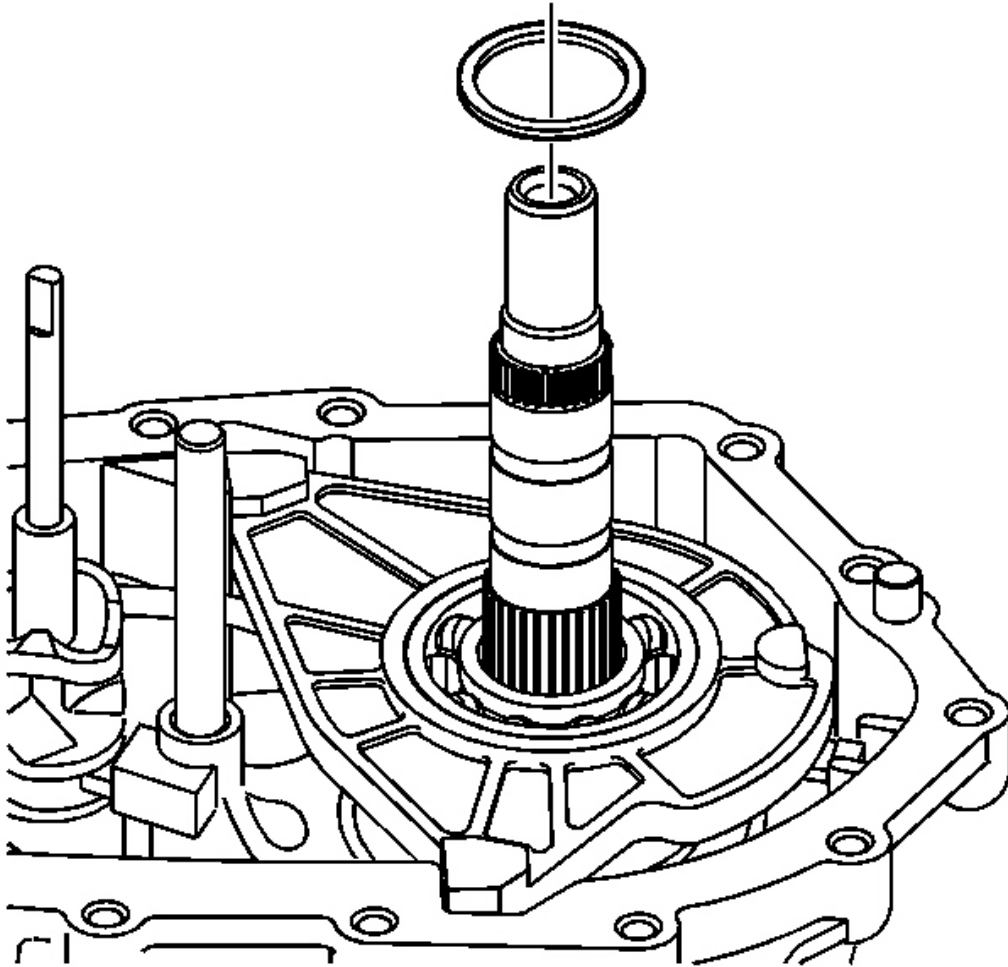

Fig. 46: Identifying Upper Thrust Washer
Courtesy of GENERAL MOTORS CORP.

31. Remove the upper thrust washer.

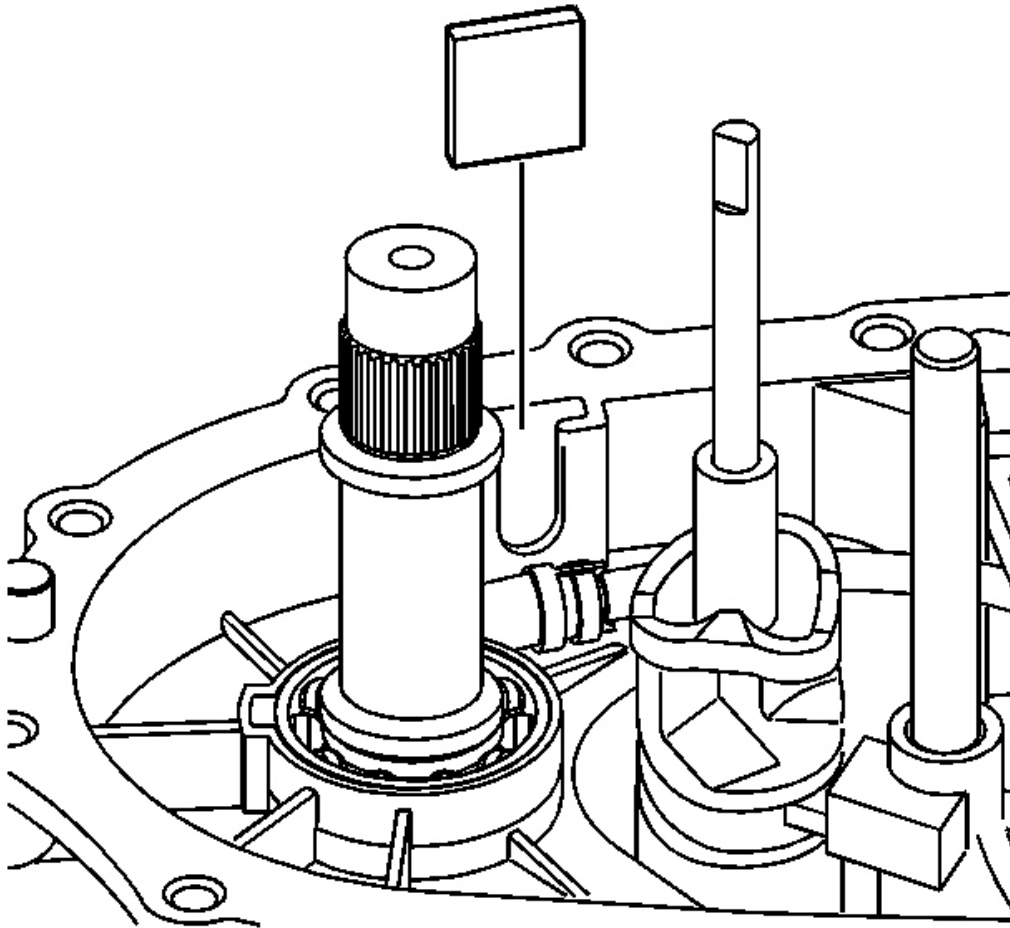

Fig. 47: Locating Magnet
Courtesy of GENERAL MOTORS CORP.

32. Remove the magnet.

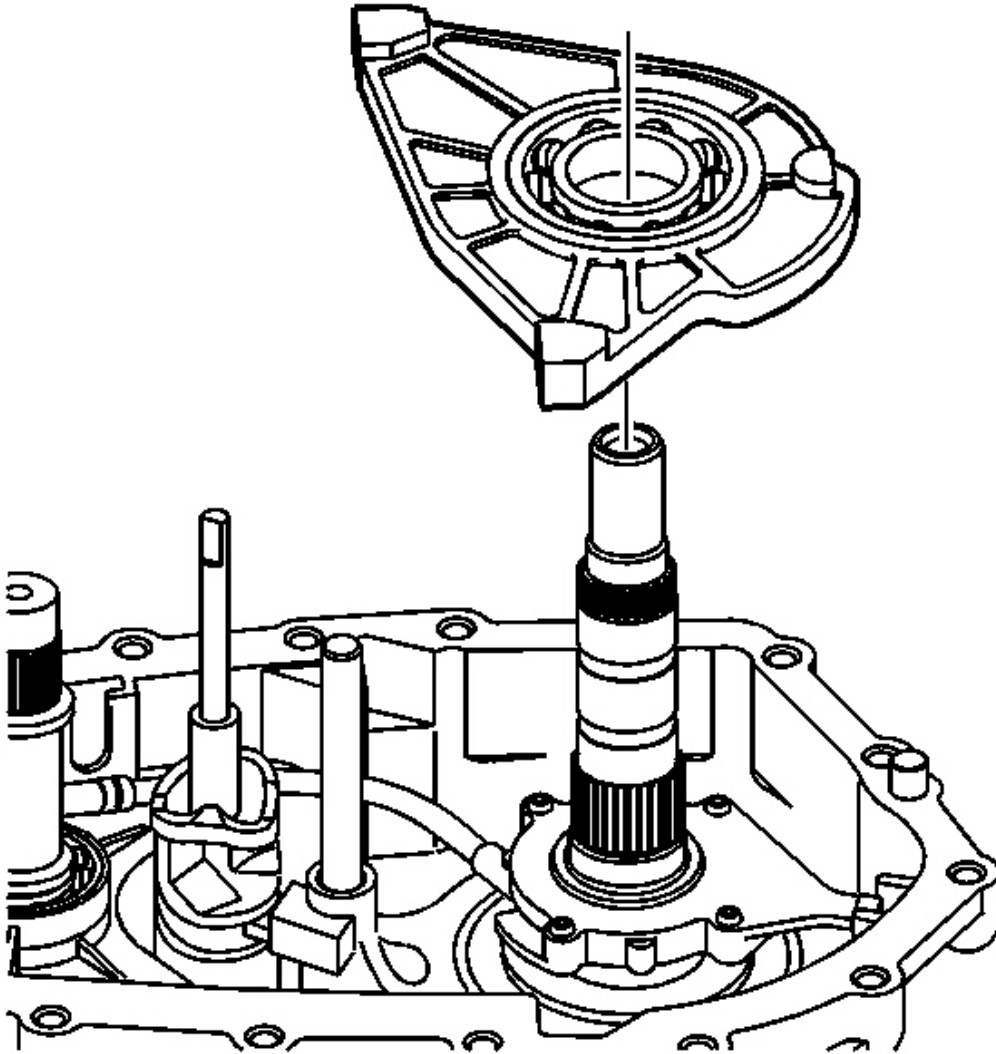

Fig. 48: Identifying Center Bearing Support
Courtesy of GENERAL MOTORS CORP.

33. Remove the center bearing support.

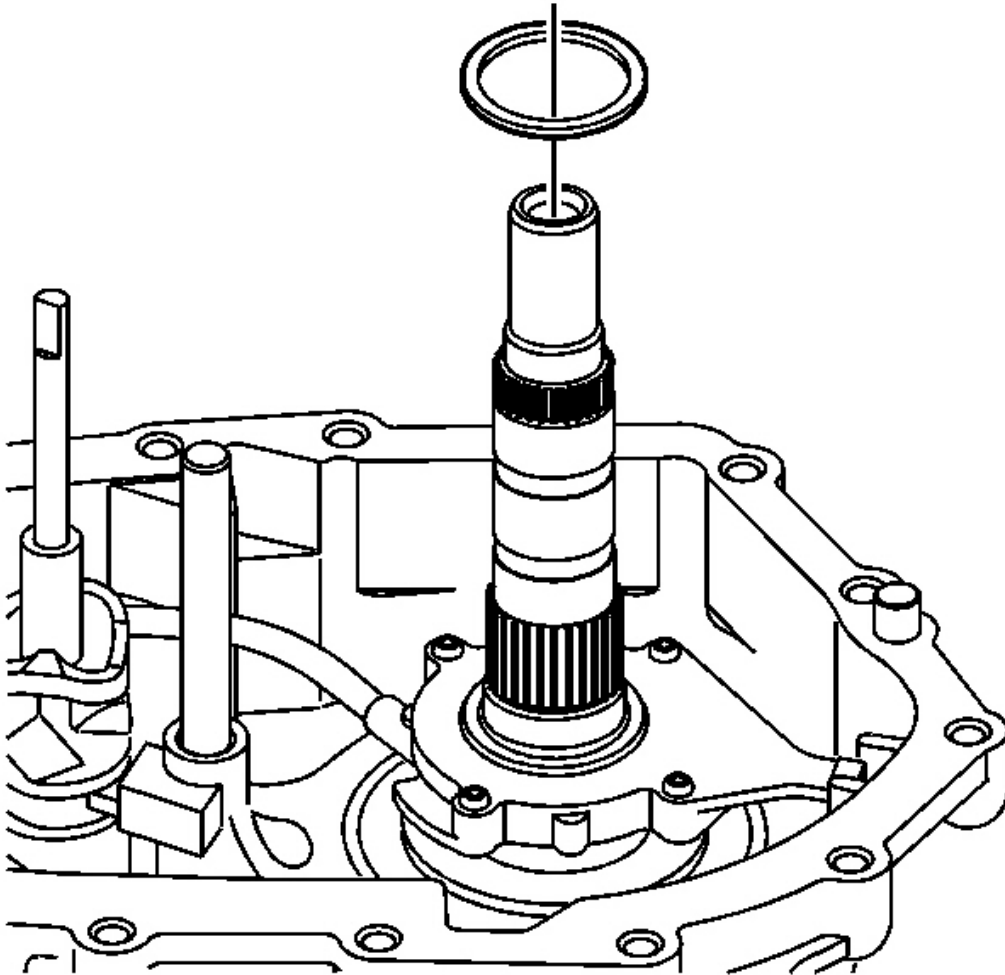

Fig. 49: Identifying Lower Thrust Washer
Courtesy of GENERAL MOTORS CORP.

34. Remove the lower thrust washer.

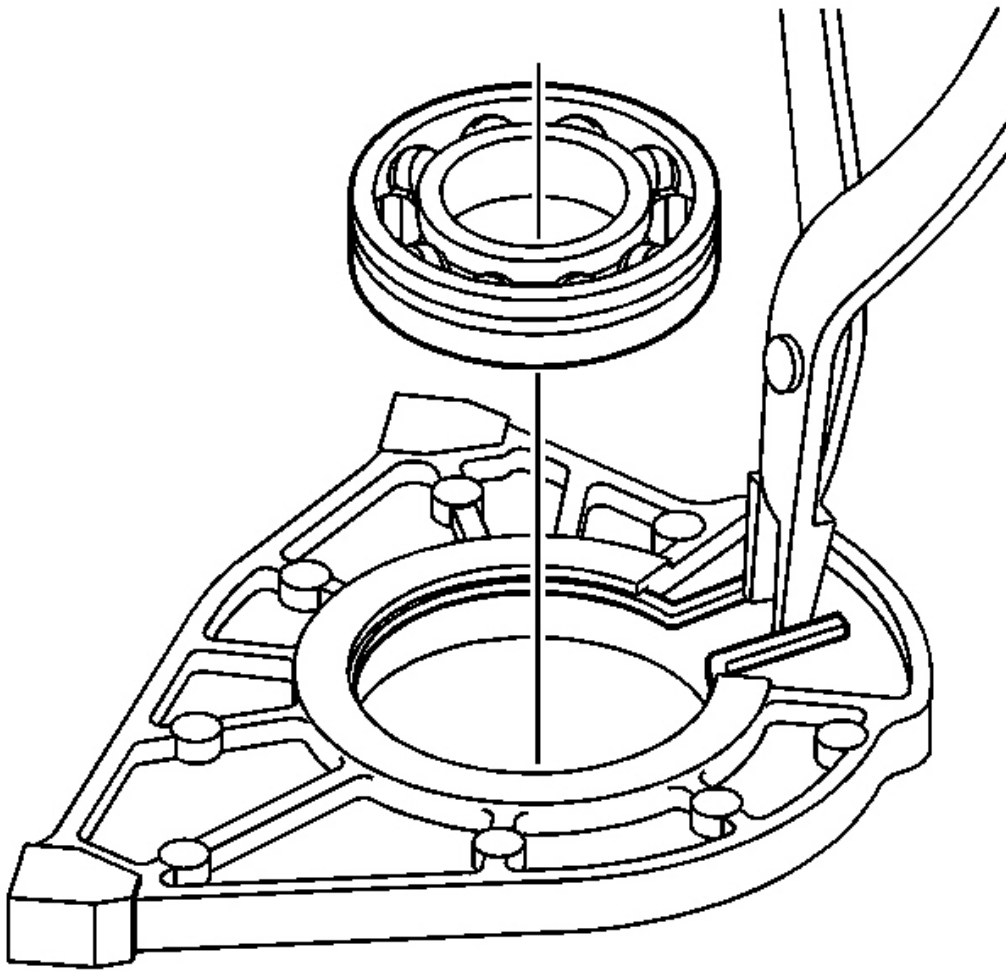

Fig. 50: Removing Bearing From Support
Courtesy of GENERAL MOTORS CORP.

35. Using a pair of needle-nose pliers, spread the snap ring in order to remove the bearing from the support, if necessary.

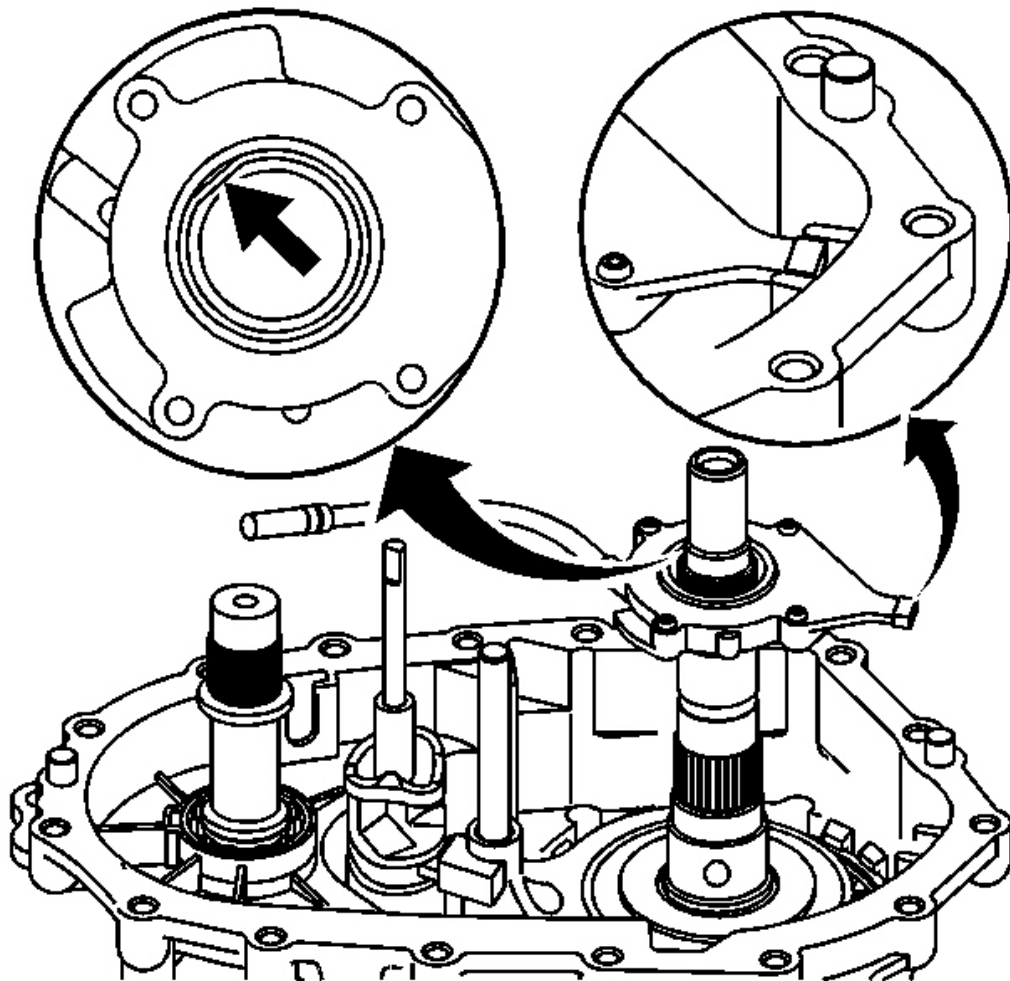

Fig. 51: Identifying Oil Pump Assembly With Hose & Screen
Courtesy of GENERAL MOTORS CORP.

36. Remove the oil pump assembly with the hose and screen.

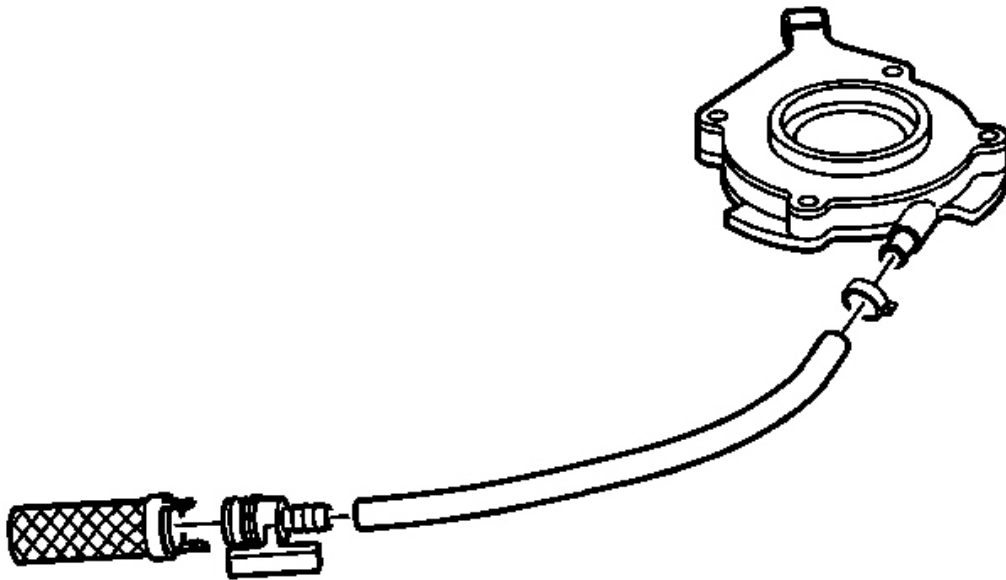

Fig. 52: Oil Pump, Hose & Oil Pump Screen
Courtesy of GENERAL MOTORS CORP.

37. Disconnect the oil pump hose from the oil pump screen.
38. Disconnect the oil pump hose from the oil pump.

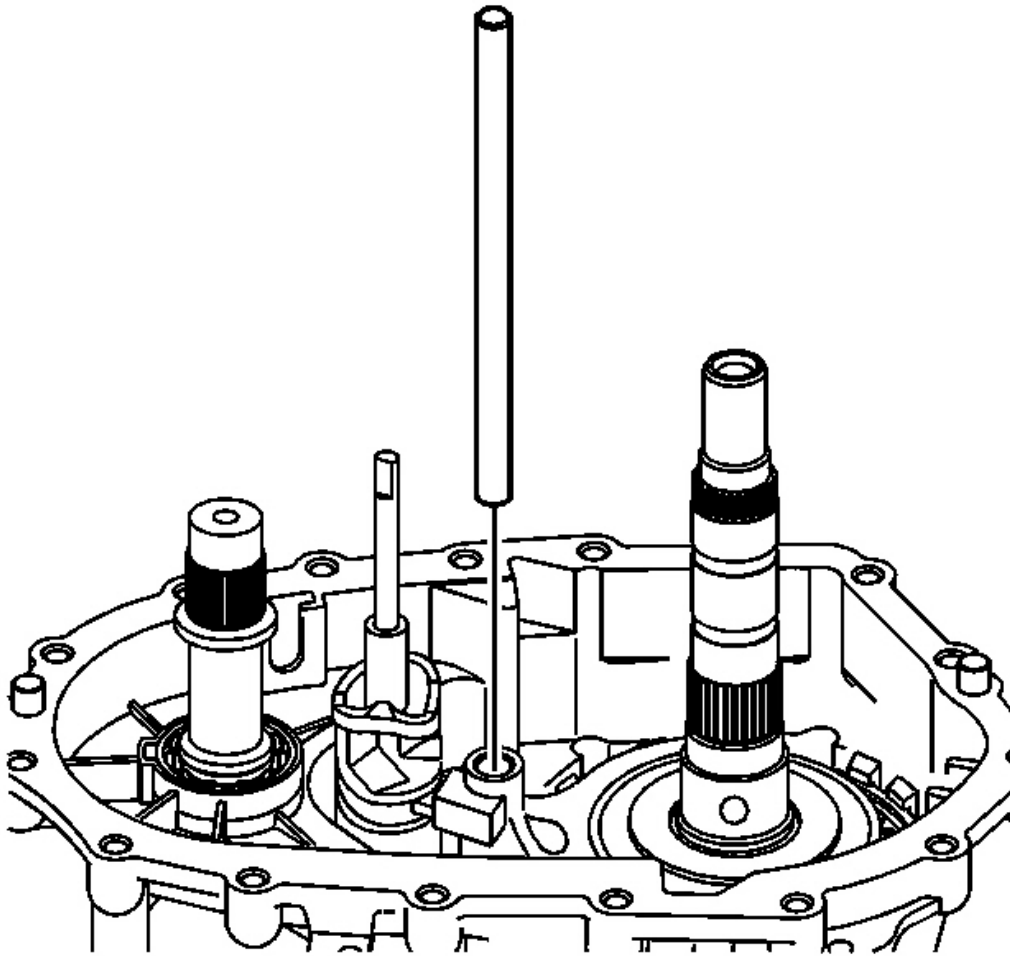

Fig. 53: Identifying Shift Fork Shaft
Courtesy of GENERAL MOTORS CORP.

39. Remove the shift fork shaft.

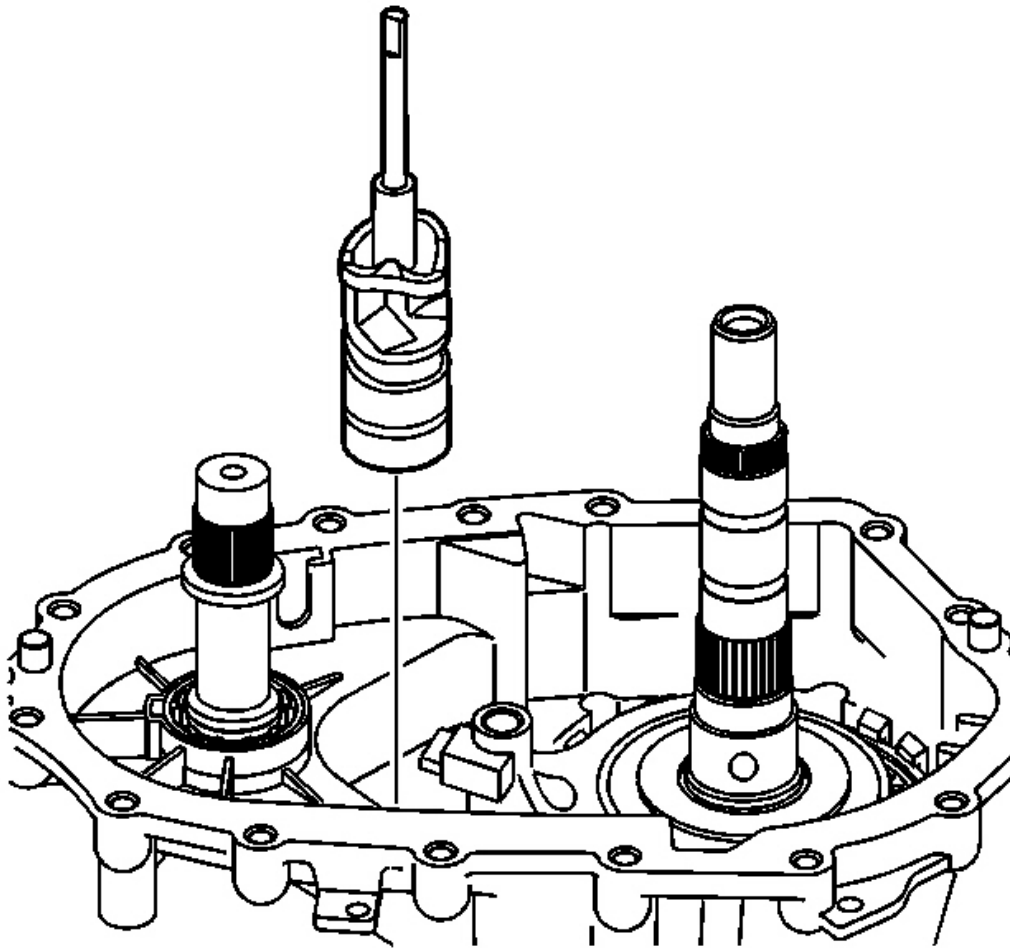

Fig. 54: Identifying Shift Cam And Shaft Assembly
Courtesy of GENERAL MOTORS CORP.

NOTE: In order to prevent component damage, properly remove and install the shift cam and shaft assembly. When removing or installing the shift cam and shaft assembly, keep the shaft straight and do not tilt. Tilting the shift cam and shaft assembly in the transfer case housing will break the tip on the end of the shaft.

40. Remove the shift cam and shaft assembly.

1. Rotate the high/low shift fork roller from the shift cam.
2. Lift straight up on the shift cam and shaft assembly.

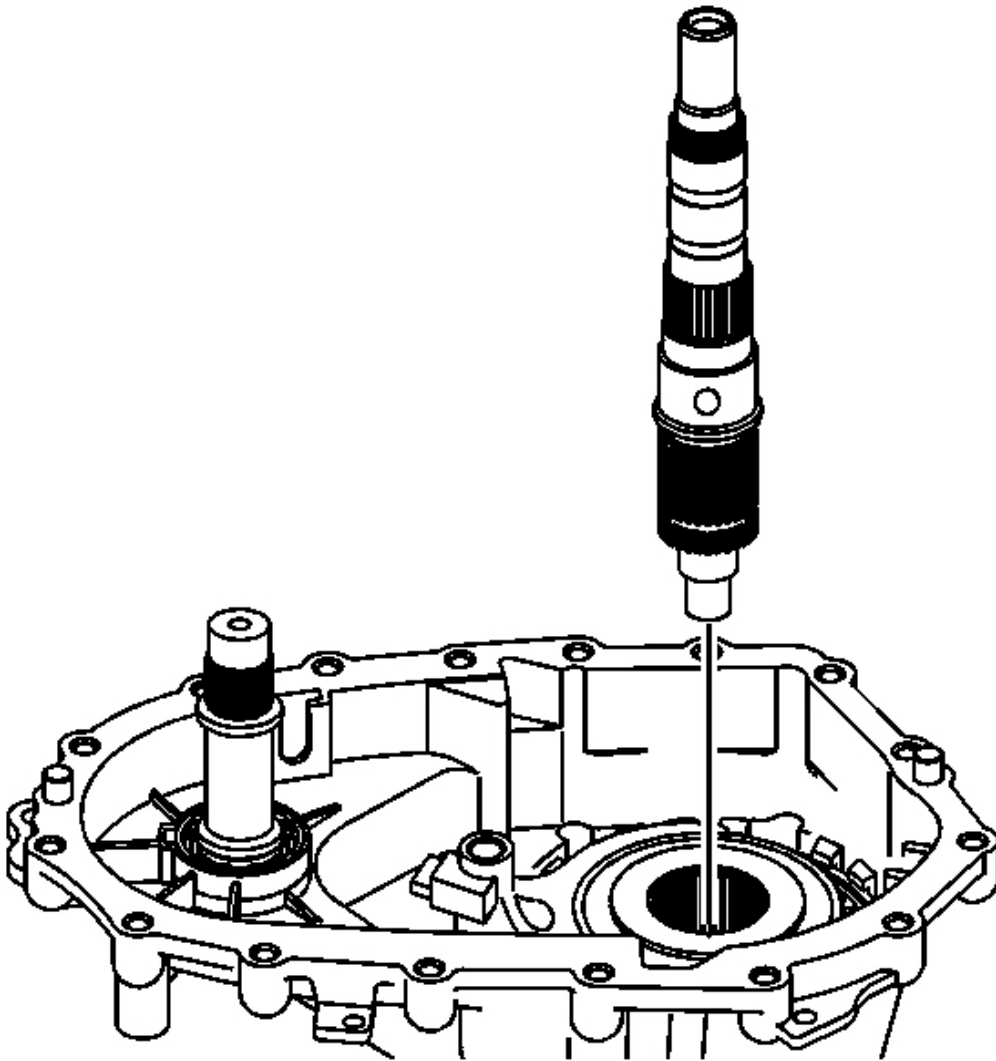

Fig. 55: Identifying Mainshaft
Courtesy of GENERAL MOTORS CORP.

41. Remove the mainshaft.

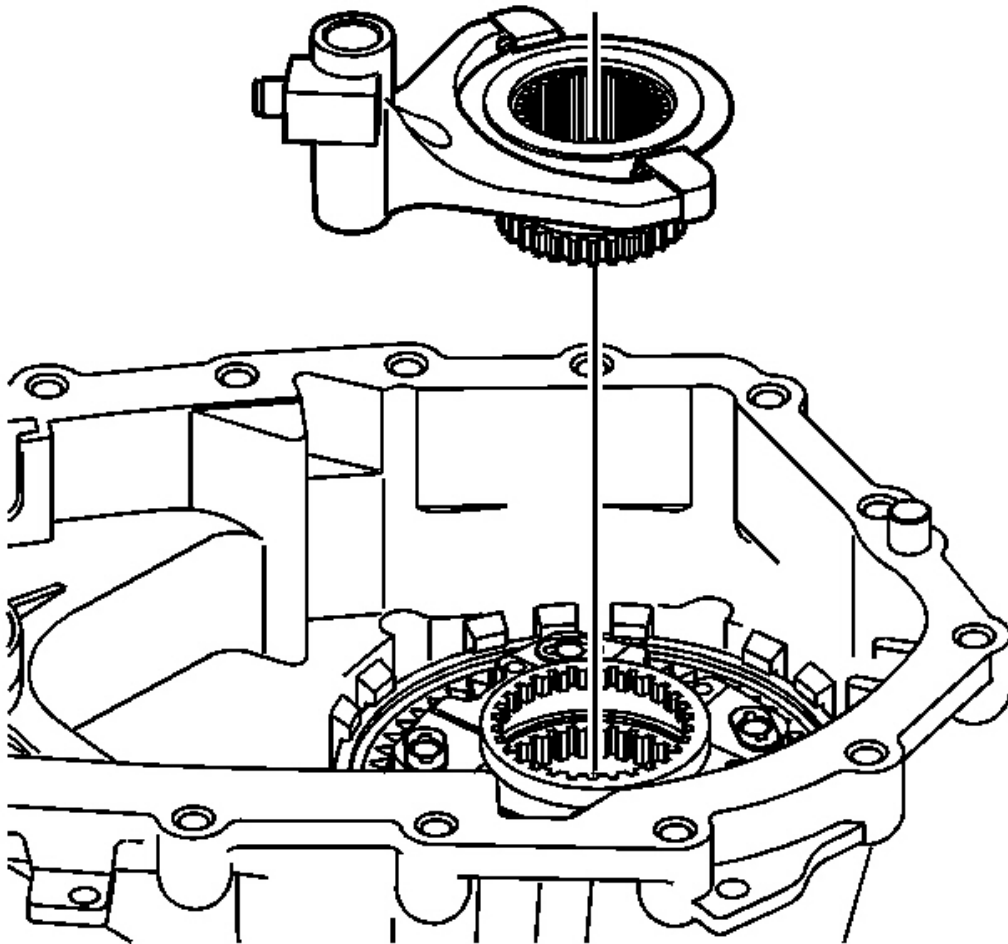

Fig. 56: View Of High/Low Range Sleeve With High/Low Range Shift Fork
Courtesy of GENERAL MOTORS CORP.

42. Remove the high/low range sleeve with the high/low range shift fork.

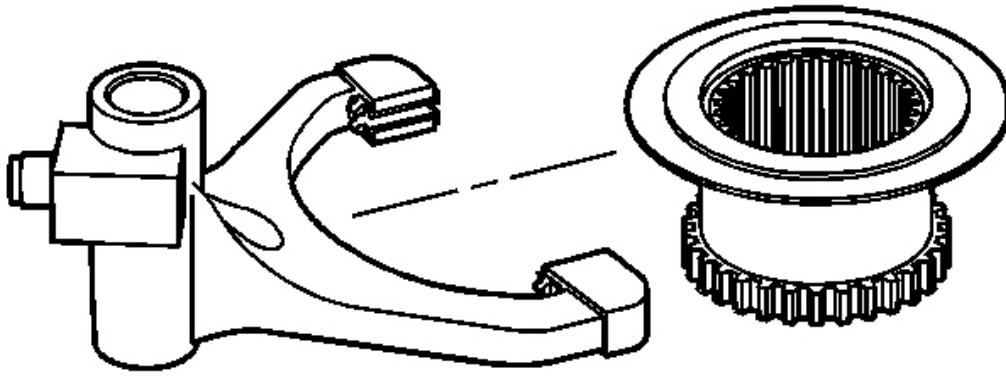

Fig. 57: View Of Range Shift Fork & Range Shift Sleeve
Courtesy of GENERAL MOTORS CORP.

43. Remove the range shift fork from the range shift sleeve.

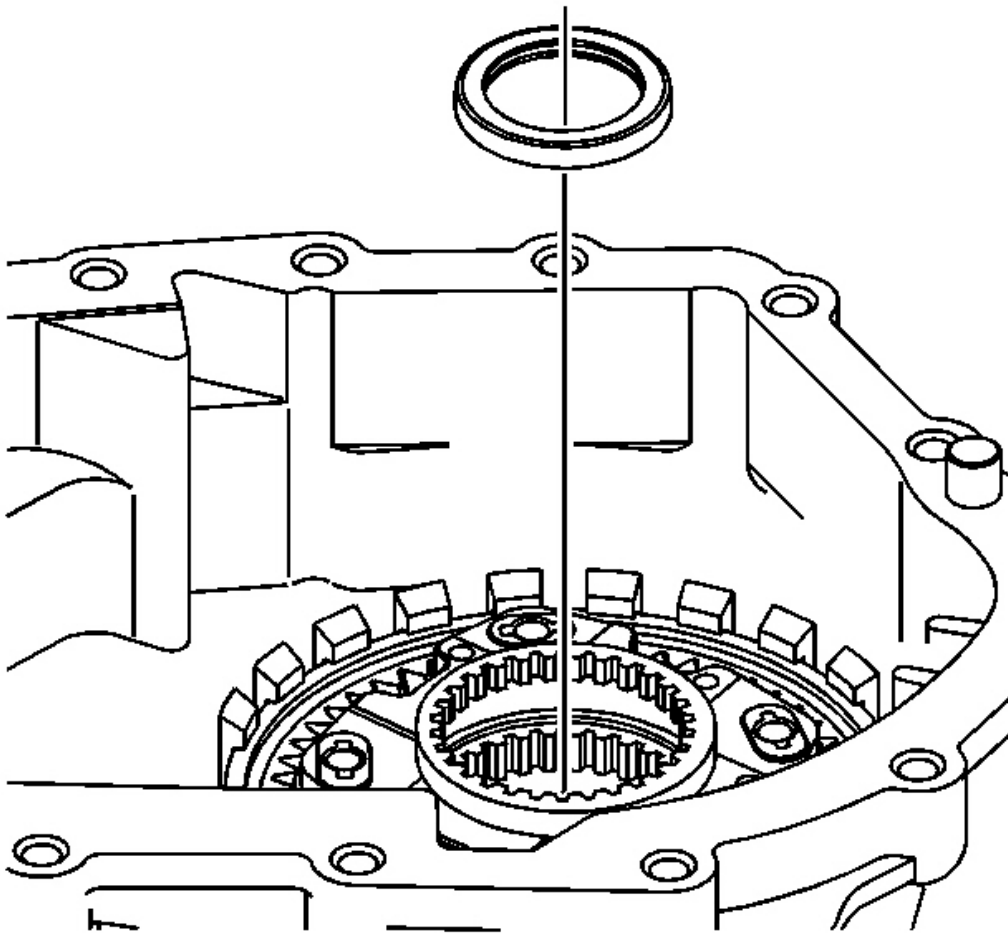

Fig. 58: Locating Input Shaft Needle Thrust Bearing
Courtesy of GENERAL MOTORS CORP.

44. Remove the input shaft needle thrust bearing.

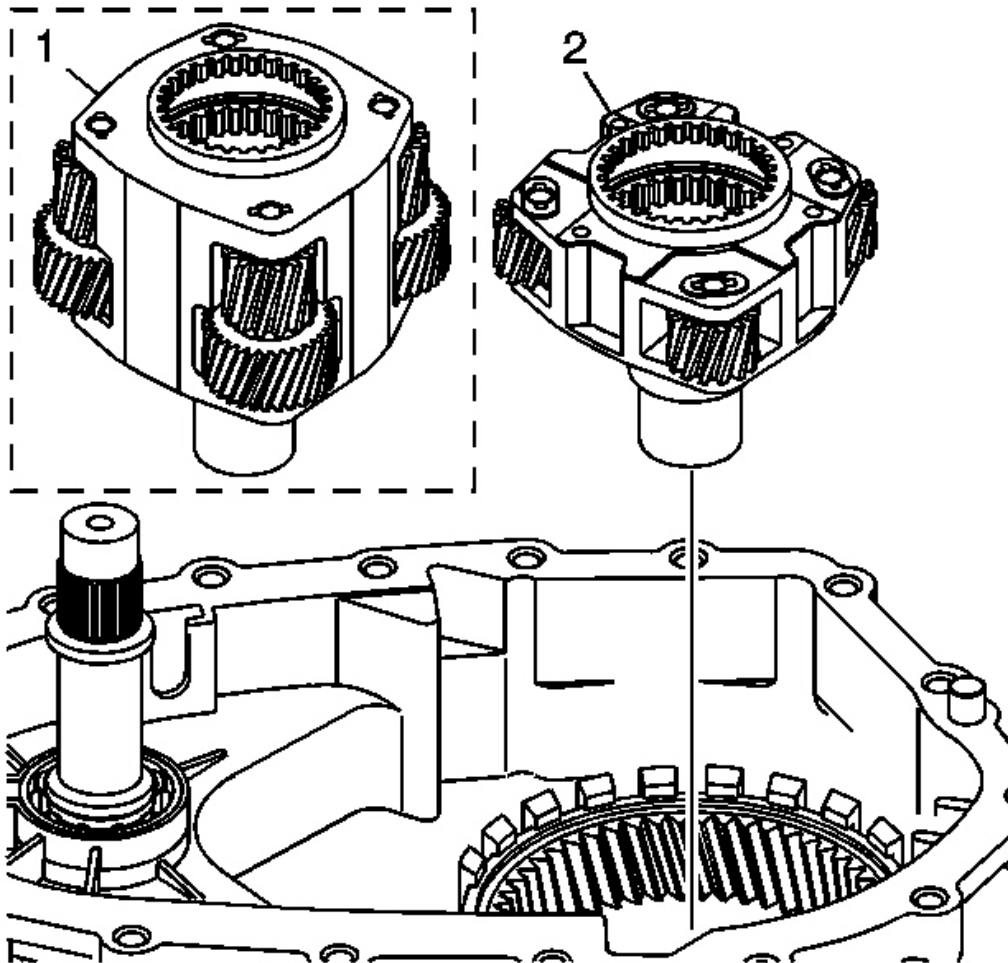

Fig. 59: View Of High/Low Planetary Carrier
Courtesy of GENERAL MOTORS CORP.

45. Remove the 4494 (1) or the 4493 (2) high/low planetary carrier.

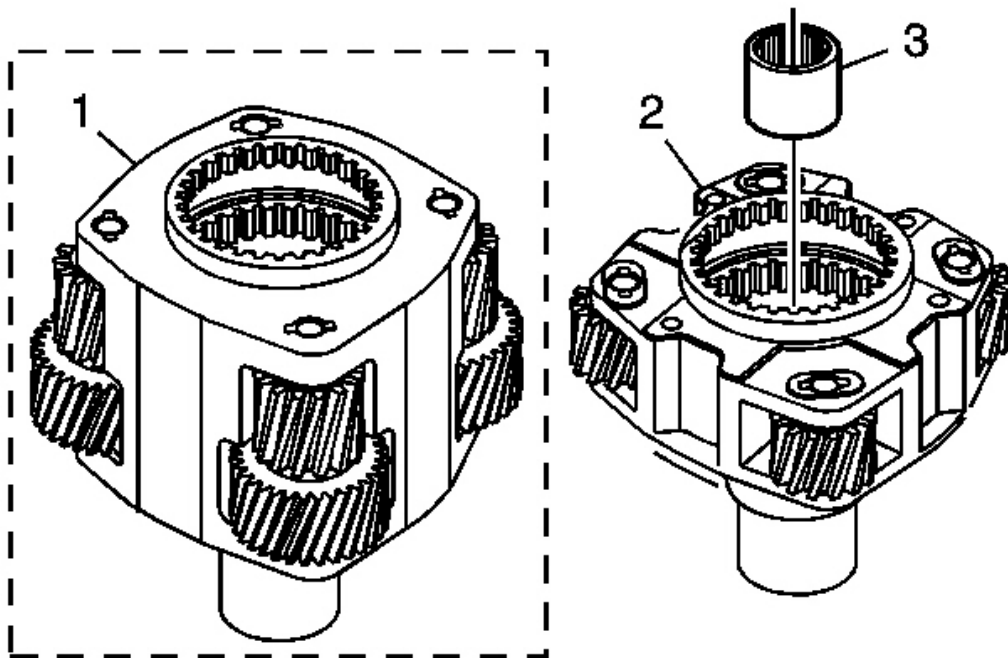

Fig. 60: Mainshaft Front Support Bearing
Courtesy of GENERAL MOTORS CORP.

46. Inspect the 4494 (1) or the 4493 (2) mainshaft front support bearing (3) for being faulty. Refer to **Cleaning and Inspection**.
47. Using a brass drift and a hammer, remove the mainshaft front support bearing (3) from the planetary carrier assembly.

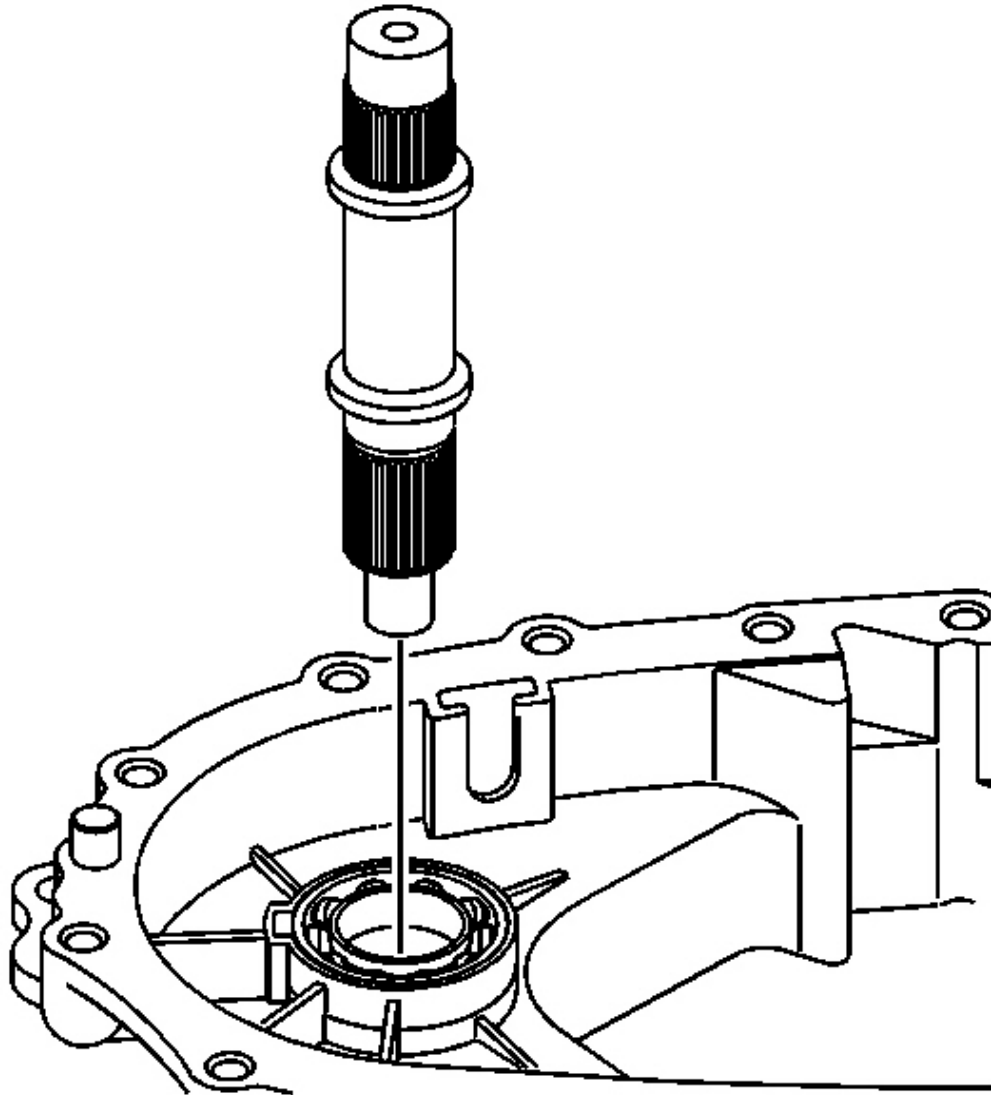

Fig. 61: Removing/Installing Front Output Shaft Assembly
Courtesy of GENERAL MOTORS CORP.

48. Remove the front output shaft assembly.

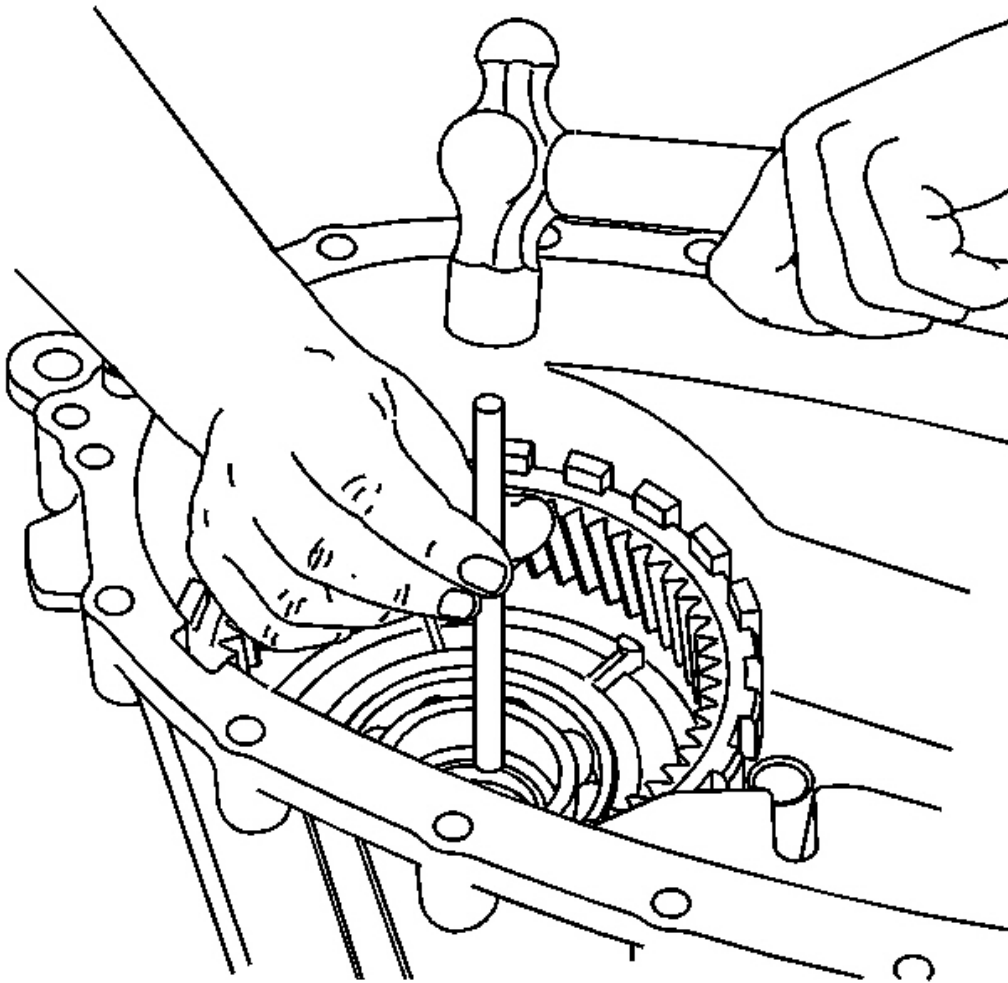

Fig. 62: View Of Input Seal
Courtesy of GENERAL MOTORS CORP.

49. Using a hammer and a suitable punch, remove the input shaft seal.

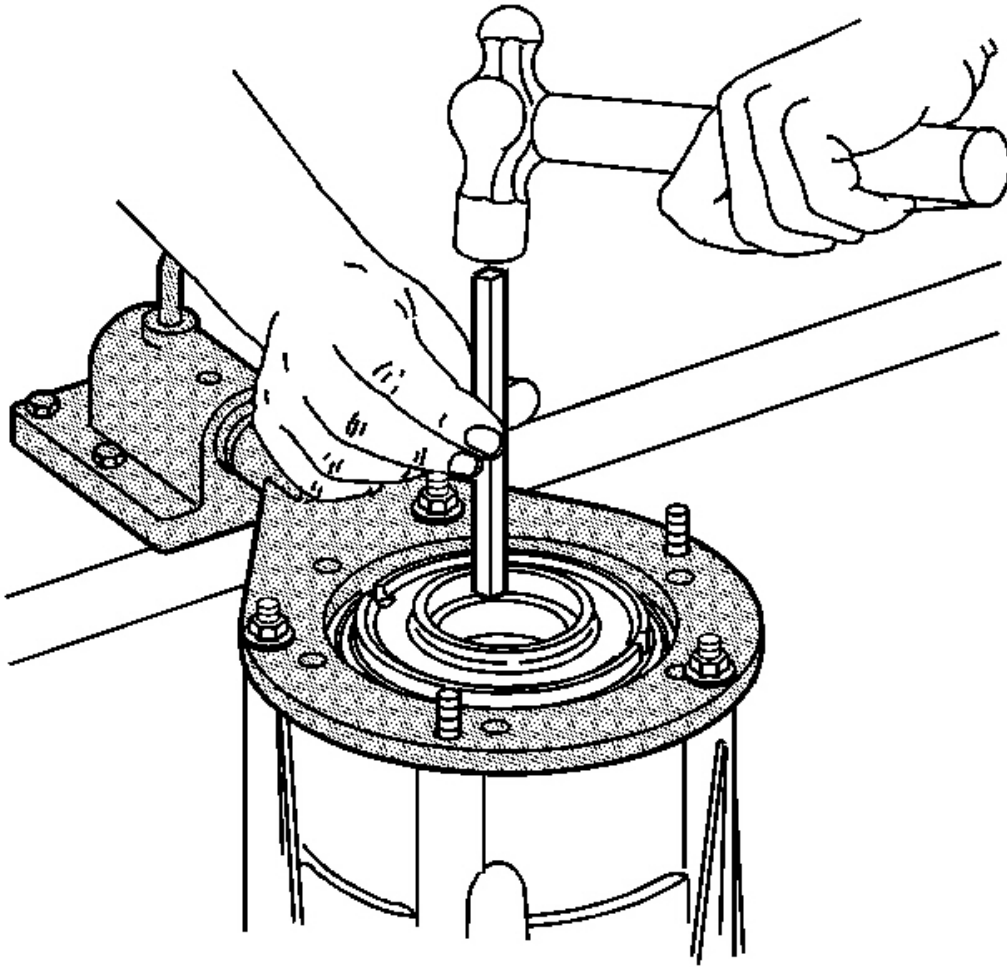

Fig. 63: Removing Input Gear Bearing From Front Case Half
Courtesy of GENERAL MOTORS CORP.

50. Using a hammer and a brass drift, remove the input gear bearing from the front case half.

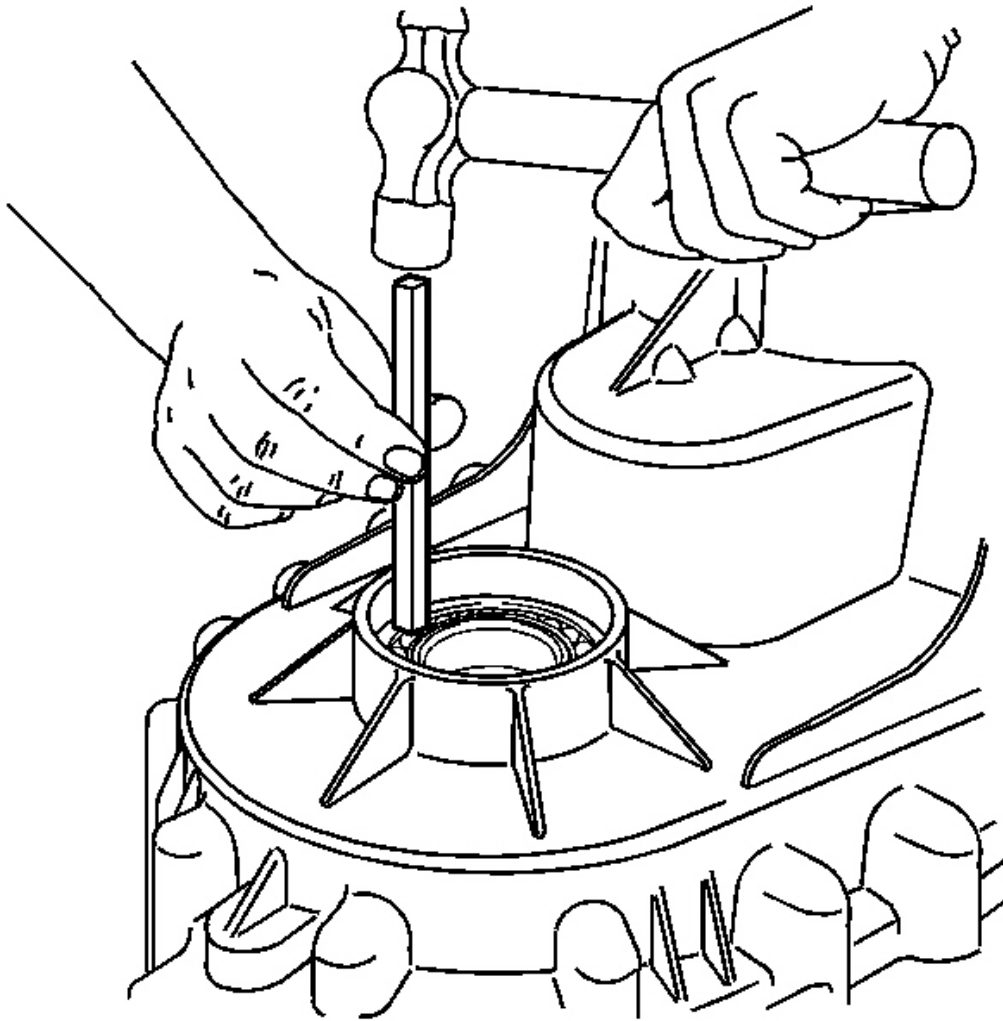

Fig. 64: Removing Front Output Shaft Bearing
Courtesy of GENERAL MOTORS CORP.

51. Using a brass drift, remove the front output shaft bearing from the front case half.

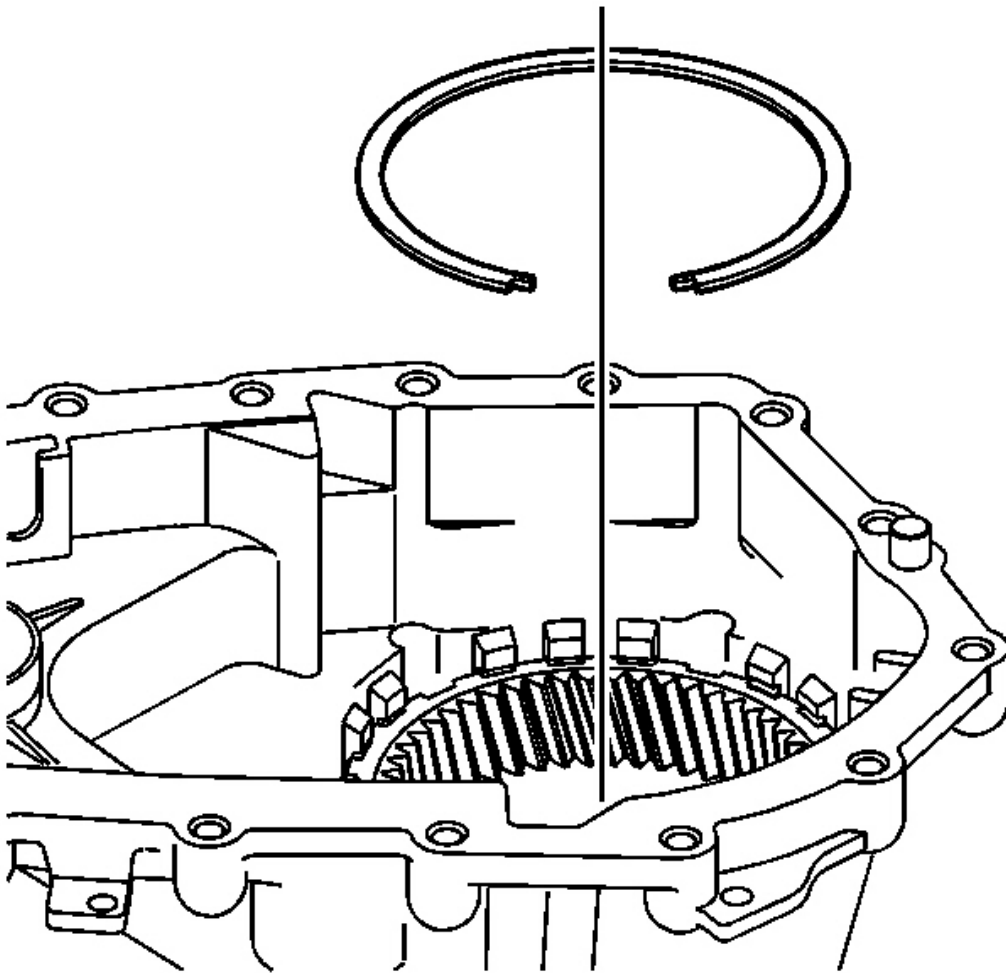

Fig. 65: Identifying Ring Gear Retaining Ring
Courtesy of GENERAL MOTORS CORP.

52. Remove the ring gear retaining ring.

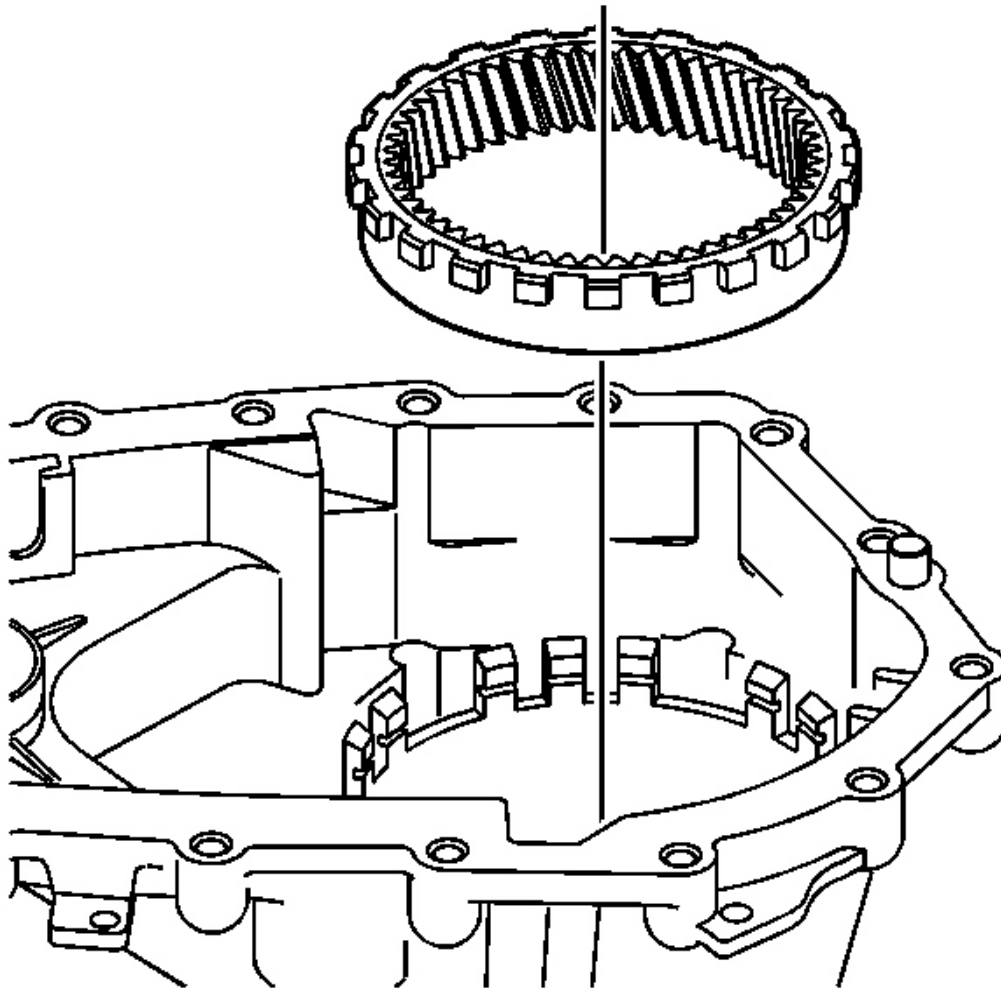

Fig. 66: Identifying Ring Gear At Front Case Half
Courtesy of GENERAL MOTORS CORP.

53. Remove the ring gear from the front case half.

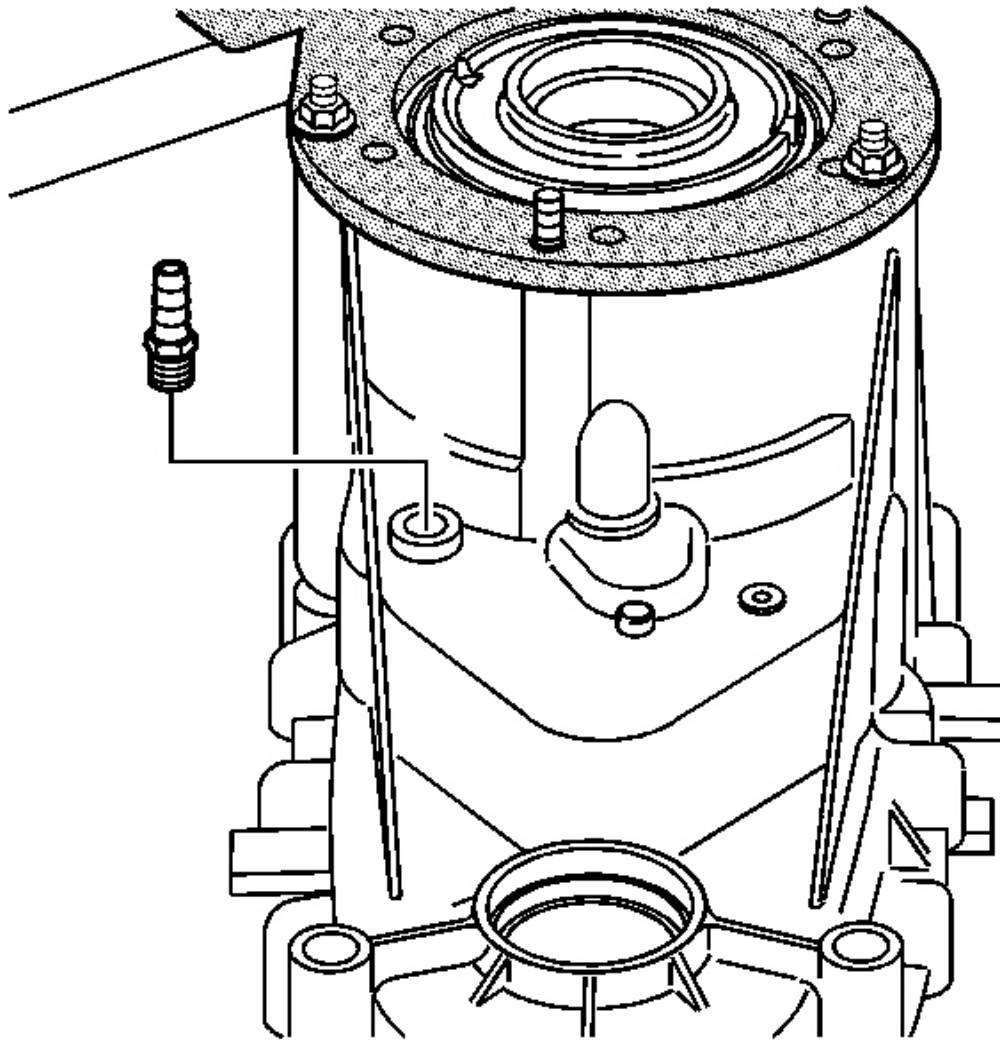

Fig. 67: Locating Front Case Half Vent
Courtesy of GENERAL MOTORS CORP.

54. If necessary, remove the vent from the front case half.

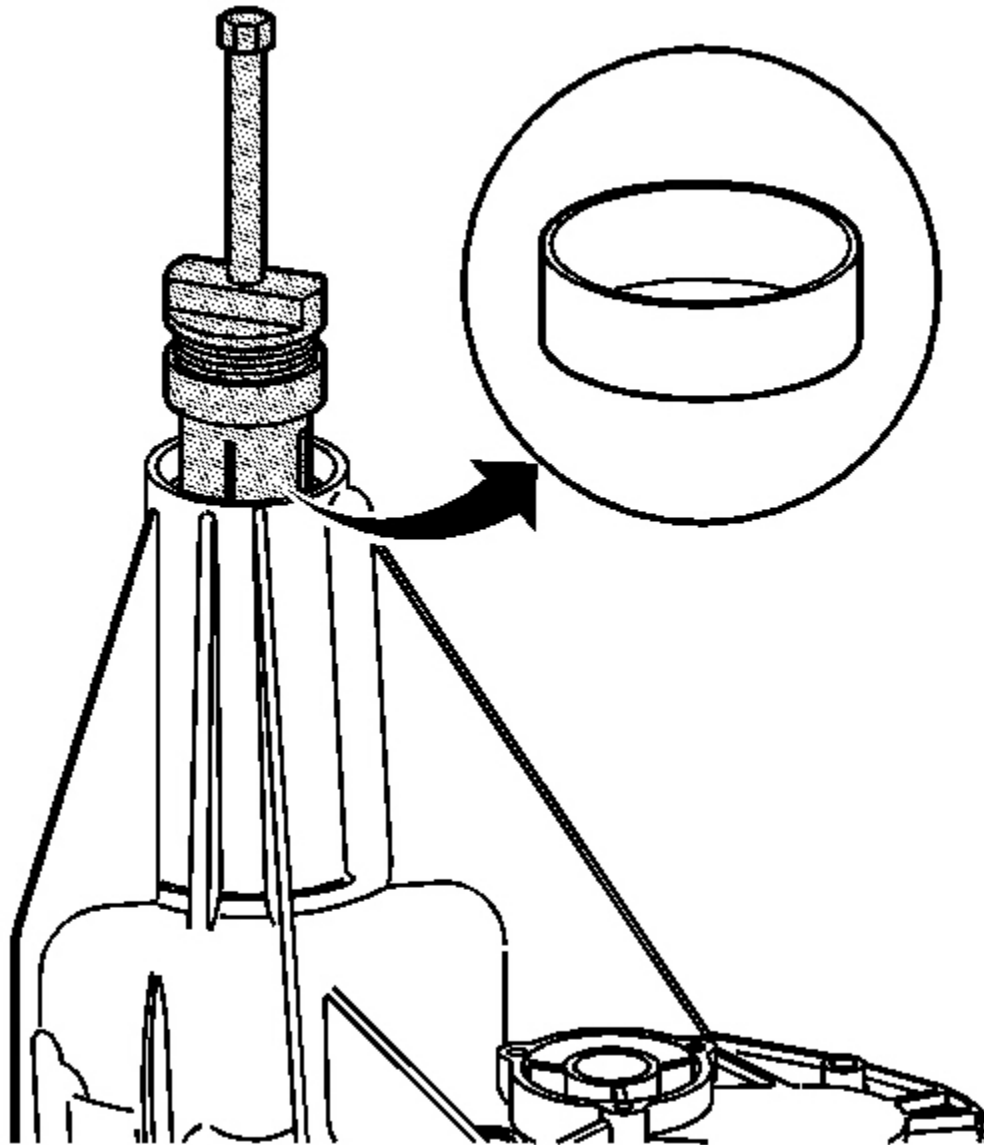

Fig. 68: Rear Output Shaft Bushing
Courtesy of GENERAL MOTORS CORP.

55. Using the **J 45380** , remove the rear output shaft bushing. See **Special Tools**.

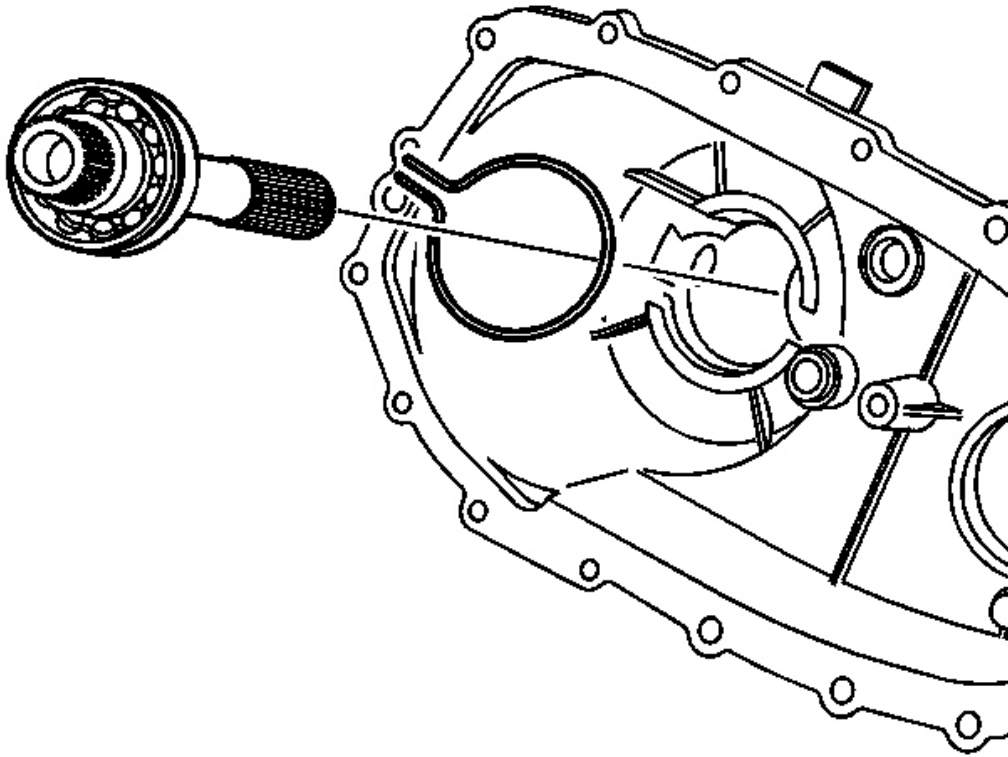

Fig. 69: Identifying Rear Output Shaft
Courtesy of GENERAL MOTORS CORP.

56. Remove the rear output shaft from the rear case half.
 1. Spread the rear output shaft rear bearing outer retaining ring.
 2. Using a soft-face hammer, tap on the end of the rear output shaft.

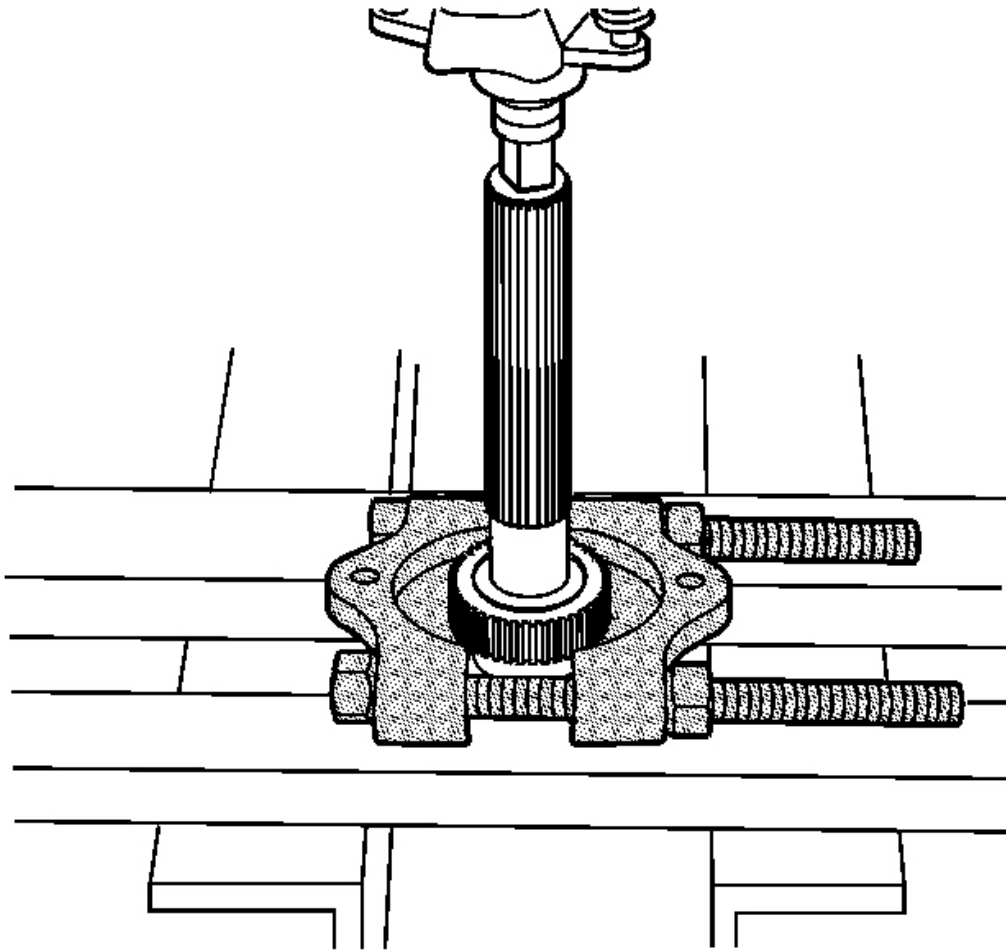

Fig. 70: Removing Speed Sensor Tone Wheel
Courtesy of GENERAL MOTORS CORP.

57. Using a hydraulic press and the **J 22912-B** , remove the speed sensor tone wheel.

Do not use the speed sensor tone wheel again.

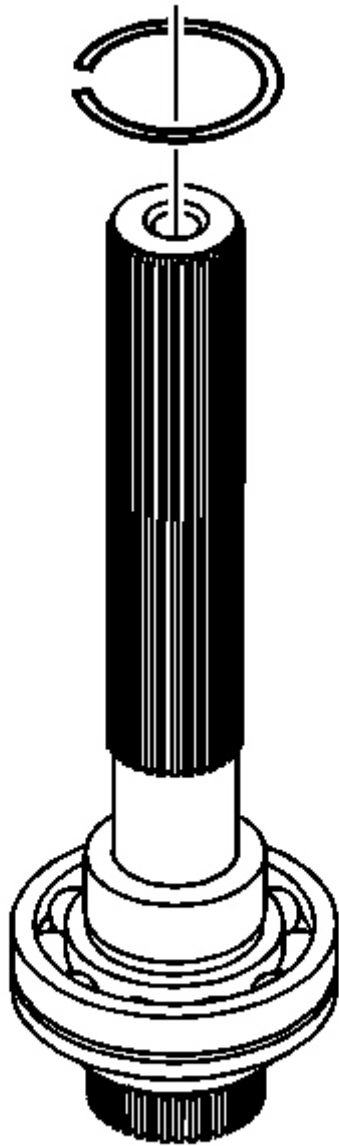

Fig. 71: Identifying Rear Output Shaft Bearing Retaining Ring
Courtesy of GENERAL MOTORS CORP.

58. Remove the rear output shaft bearing retaining ring.

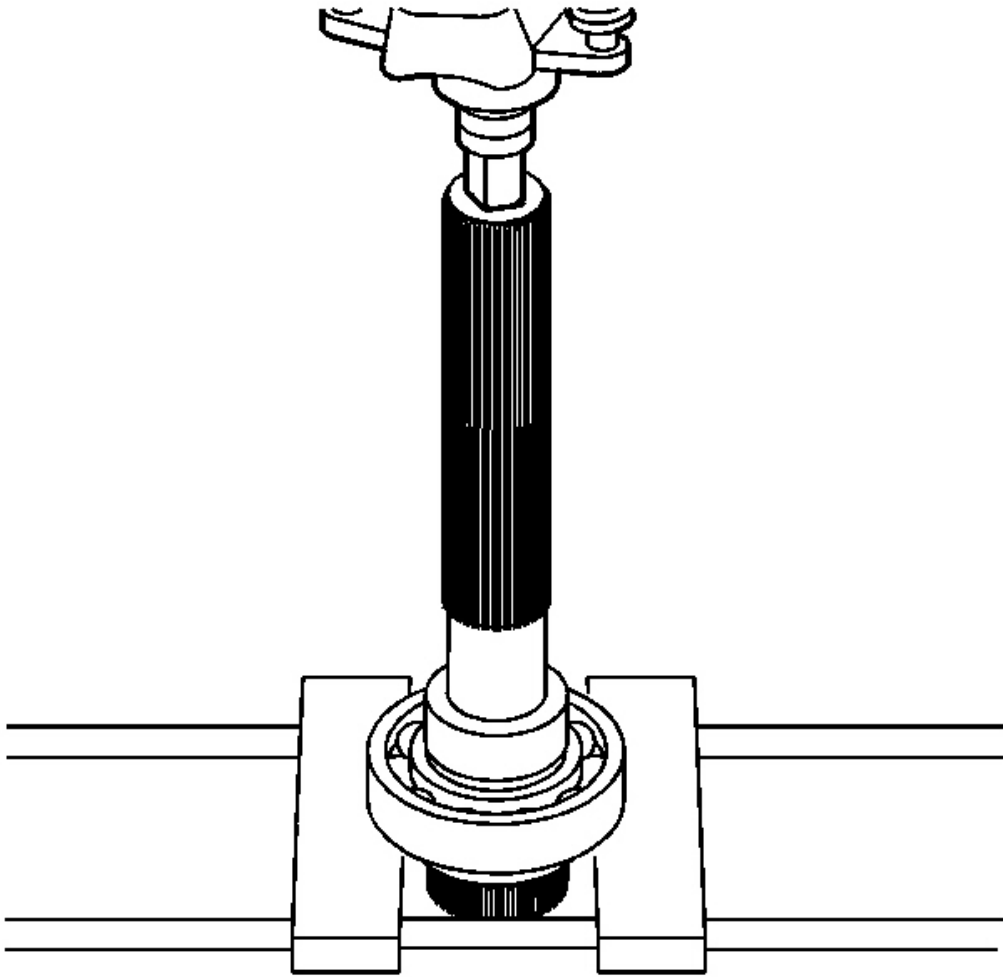

Fig. 72: Rear Output Shaft Bearing
Courtesy of GENERAL MOTORS CORP.

59. Using a hydraulic press, remove the rear output shaft bearing.

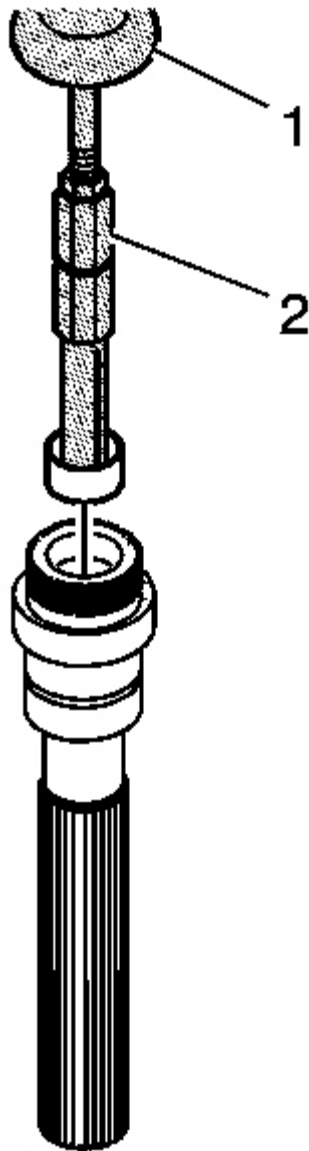

Fig. 73: Removing Mainshaft Rear Support Bushing From Rear Output Shaft
Courtesy of GENERAL MOTORS CORP.

60. Inspect the mainshaft rear support bushing, in the rear output shaft, for being faulty. Refer to **Cleaning and Inspection**.

61. Using the **J 2619-01** (1) and the **J 45548** (2), remove the mainshaft rear support bushing from the rear output shaft. See **Special Tools**.

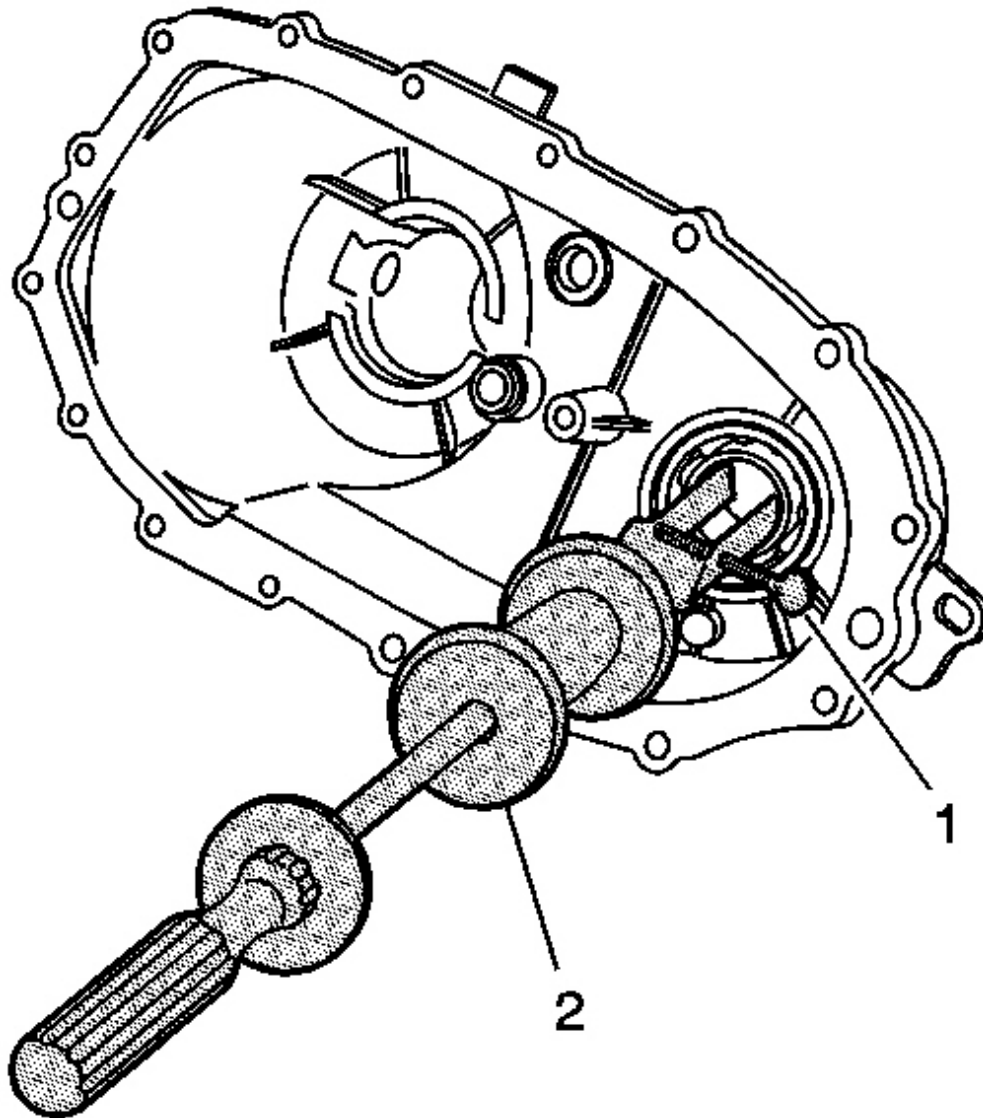

Fig. 74: Removing Front Output Shaft Rear Bearing From Rear Case
Courtesy of GENERAL MOTORS CORP.

62. Using the **J 29369-1** (1) and the **J 23907** (2), remove the front output shaft rear bearing from the rear case.

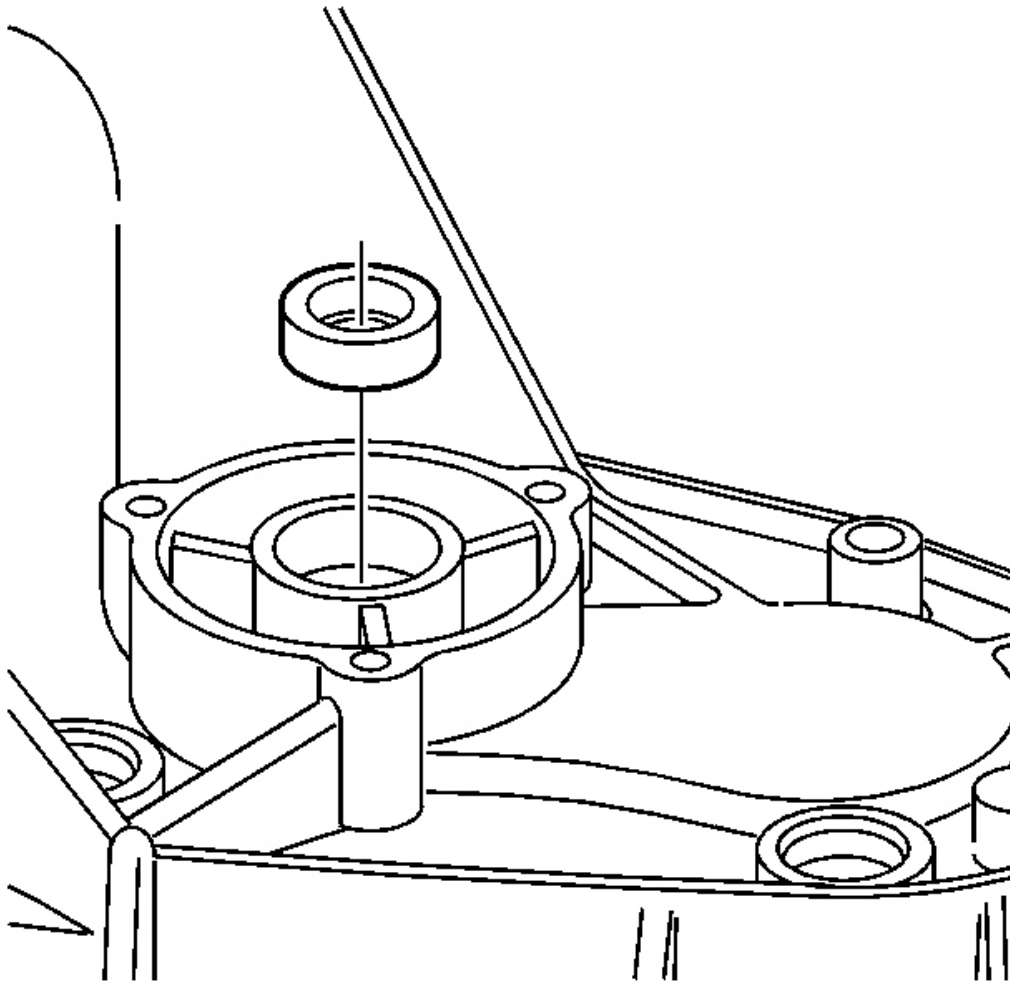

Fig. 75: Locating Shift Shaft Seal
Courtesy of GENERAL MOTORS CORP.

63. Remove the shift shaft seal by prying it out of the case.

CLEANING AND INSPECTION

Front Case Half

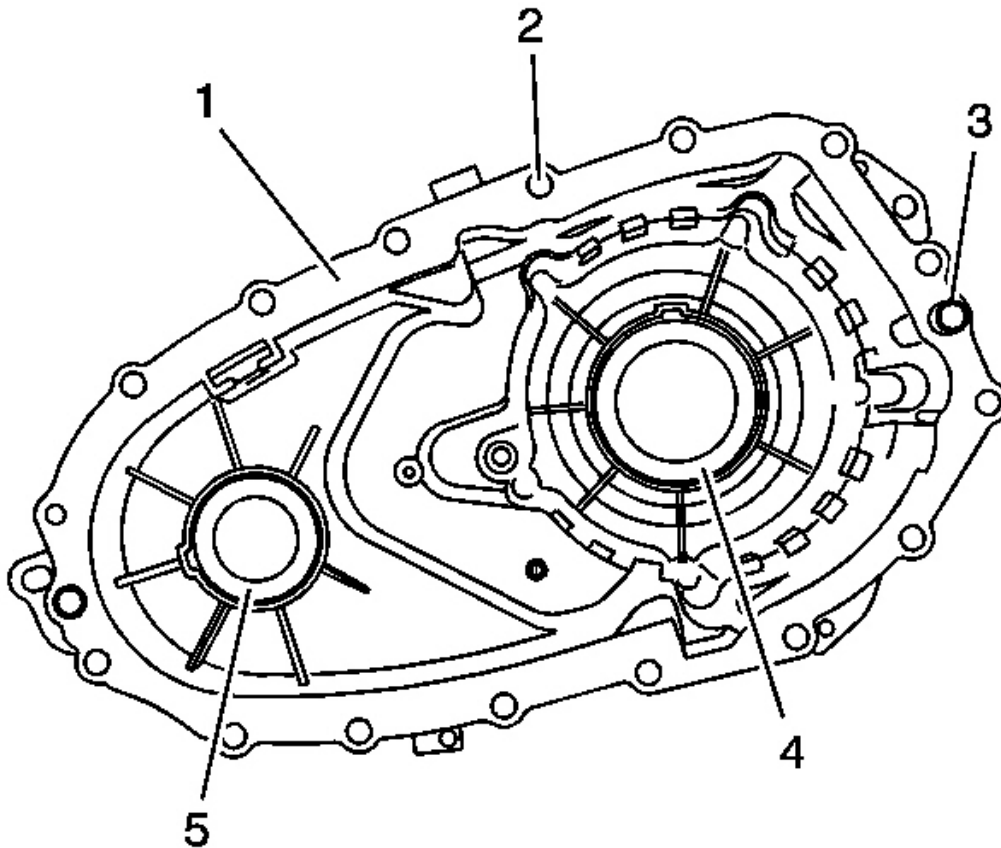

Fig. 76: Front Case Half
Courtesy of GENERAL MOTORS CORP.

1. Clean the front case half in cleaning solvent and air dry.
2. Remove the shavings from the case half bolt holes.

NOTE: Refer to Machined Surface Damage Notice .

3. Remove the sealer from the case sealing surfaces.
4. Inspect the case for being broken or cracked.
5. Inspect the front output shaft front bearing bore (5) for the following conditions:
 - A spun bearing
 - Cracks

2007 Hummer H3

2007 TRANSMISSION Transfer Case - BW 4493/4494 - H3

6. Inspect the input shaft bearing bore (4) for the following conditions:
 - A spun bearing
 - Cracks
7. Replace the front case half if any of the above conditions are found.
8. Inspect the sealing surfaces (1) for damage.
9. Repair small scratches or nicks with a soft stone.
10. Inspect the front case to transmission case mounting surface for damage.
11. Inspect the case threaded bolt holes (2) for damage.
12. Repair any damaged threads.
13. Inspect the transmission to transfer case studs for damage.
14. Replace any damaged studs.
15. Inspect the location pins (3) for being loose or missing.
16. Repair or replace any damaged location pins.
17. Inspect the front output shaft front bearing and the input shaft bearing for the following conditions:
 - Roughness
 - Brinelling
 - Pitting
18. Replace the bearings if any of the above conditions are found. Refer to **Transfer Case Disassemble** and **Transfer Case Assemble**.

Rear Case Half

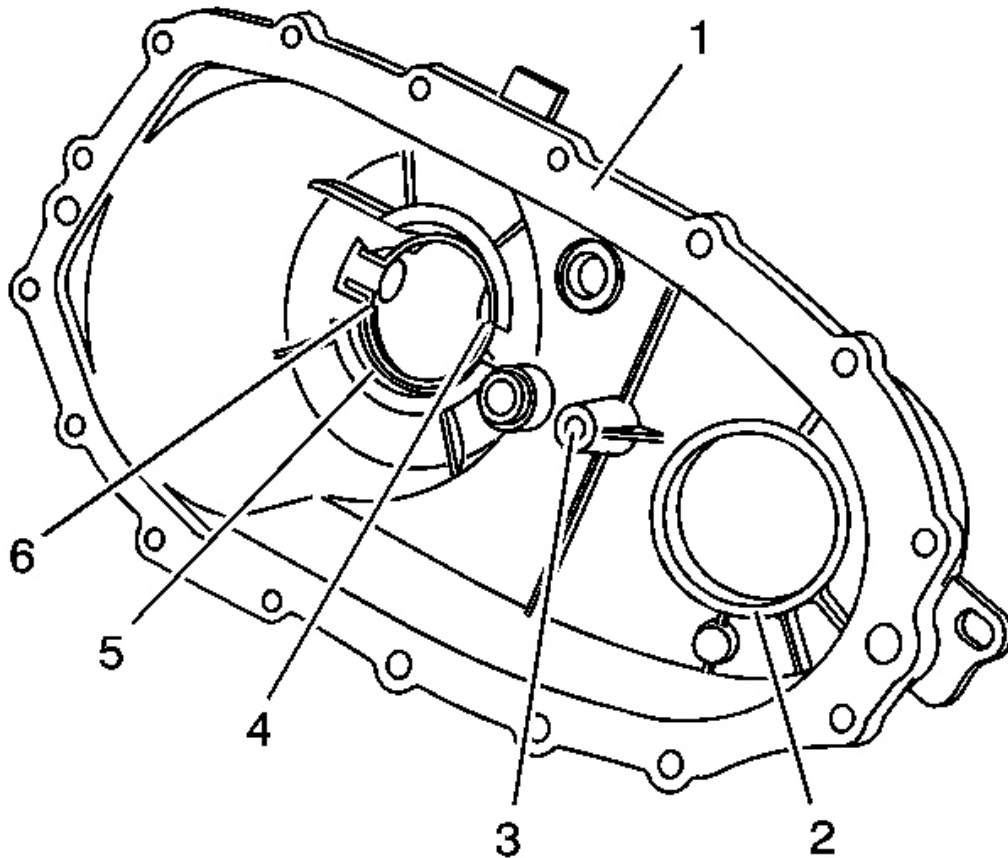

Fig. 77: Rear Case Half

Courtesy of GENERAL MOTORS CORP.

1. Clean the rear case half in cleaning solvent and air dry.

NOTE: Refer to Machined Surface Damage Notice .

2. Remove the sealer from the case sealing surfaces.
3. Inspect the case for being broken or cracked.
4. Replace the case if it is broken or cracked.
5. Inspect the sealing surfaces (1) for damage.
6. Repair small scratches or nicks with a soft stone.
7. Inspect the case threaded bolt holes for damage.

2007 Hummer H3

2007 TRANSMISSION Transfer Case - BW 4493/4494 - H3

8. Repair any damaged threads.
9. Inspect the front output shaft rear bearing bore (2) for the following conditions:
 - Spun bearing
 - Cracks
10. Inspect the rear output shaft rear bearing bore (5) for the following conditions:
 - Spun bearing
 - Cracks
11. Replace the case if the bearing has spun. Refer to **Transfer Case Disassemble** and **Transfer Case Assemble**.
12. Inspect the retaining ring (6) for the rear output shaft rear bearing for being bent or twisted.
13. Replace a faulty retaining ring.
14. Inspect the rear output shaft bushing (4) for scoring or wear.
15. Replace the rear output shaft bushing if it is faulty. Refer to **Transfer Case Disassemble** and **Transfer Case Assemble**.
16. Inspect the shift shaft bore (3) for the following conditions:
 - Out of round
 - Excessive wear
17. Replace the case if the shift shaft bore is faulty. Refer to **Transfer Case Disassemble** and **Transfer Case Assemble**.

Center Bearing Support

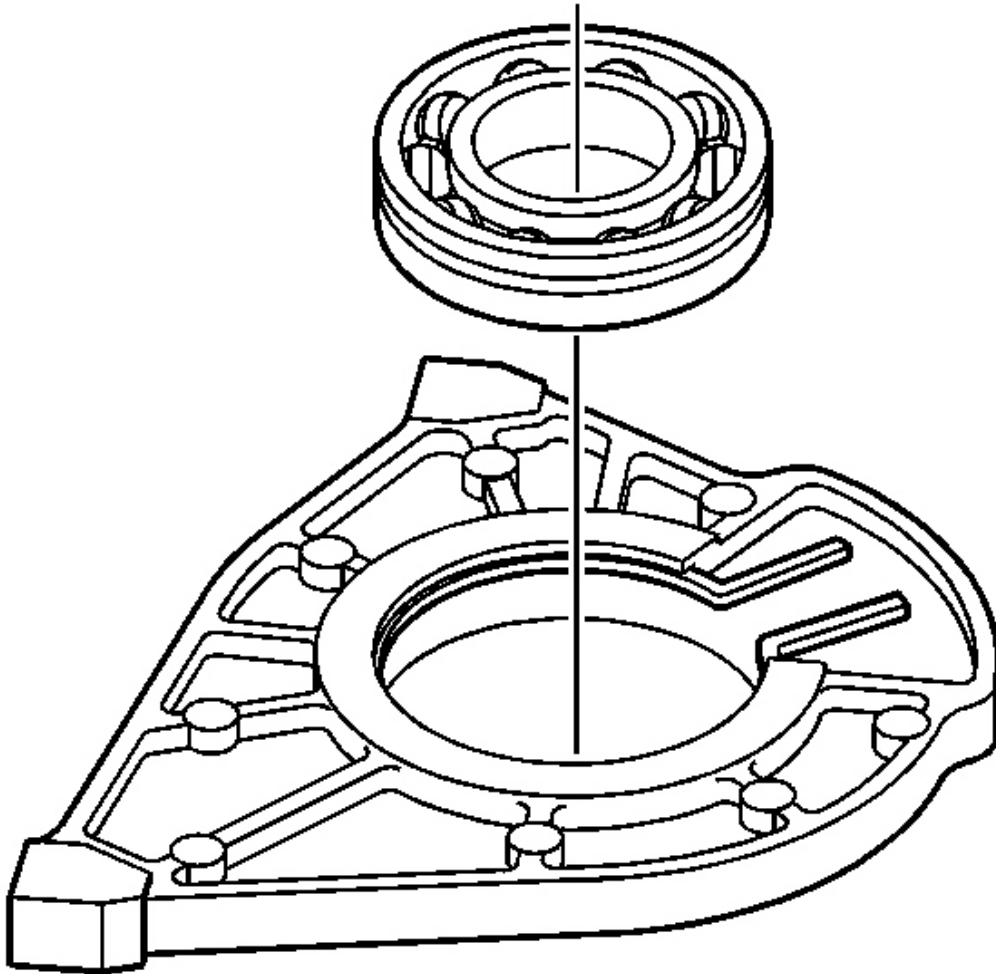

Fig. 78: Center Bearing Support
Courtesy of GENERAL MOTORS CORP.

1. Clean the center bearing support in cleaning solvent and air dry.

NOTE: Refer to Machined Surface Damage Notice .

2. Inspect the center bearing support for being broken or cracked.
3. Replace the center bearing support if it is broken or cracked. Refer to Transfer Case Disassemble and Transfer Case Assemble.

4. Inspect the center bearing support bearing bore for the following conditions:
 - Spun bearing
 - Cracks
5. Replace the center bearing support if the bearing has spun.
6. Inspect the center bearing retaining ring for being bent or twisted.
7. Replace the center bearing retaining ring if it is faulty.
8. Inspect the center support bearing for the following conditions:
 - Roughness
 - Brinelling
 - Pitting
9. Replace the bearing if any of the above conditions are found. Refer to **Transfer Case Disassemble** and **Transfer Case Assemble**.

Oil Pump

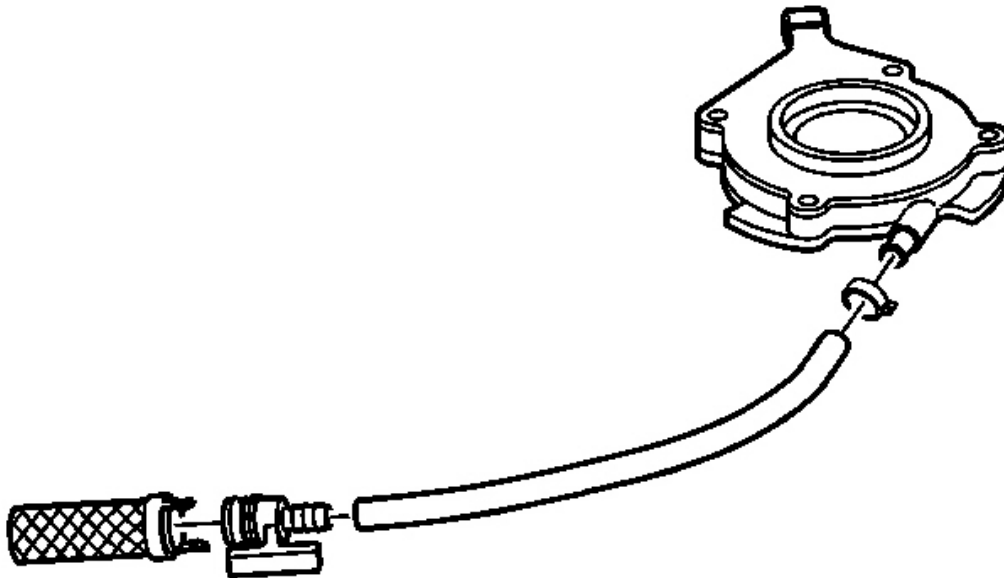

Fig. 79: Oil Pump, Hose & Oil Pump Screen
Courtesy of GENERAL MOTORS CORP.

1. Remove the oil pump suction hose from the oil pump screen.
2. Clean the hose and screen in cleaning solvent and air dry.
3. If the screen is embedded with debris, replace the screen.
4. Inspect the hose for cracking or tears.
5. Replace the hose if it is faulty.
6. Inspect the oil pump for free movement.
7. Replace the oil pump if there is any binding. Do not disassemble the oil pump. The oil pump is serviced as a unit.
8. Inspect the wear clip on the oil pump.
9. Replace the oil pump if the wear clip is missing or faulty.

High/Low Range Components

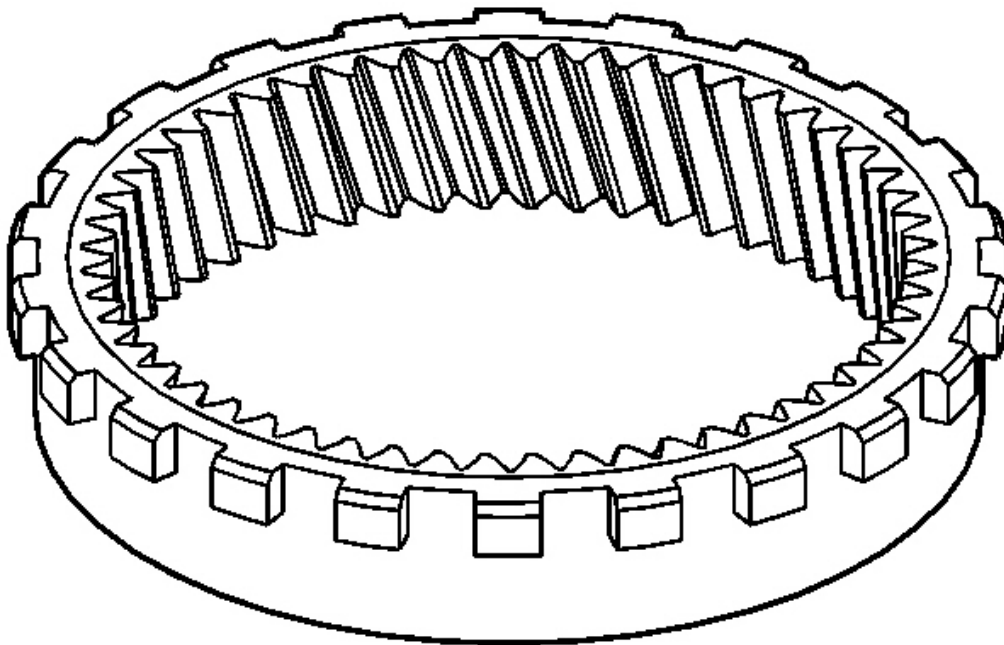

Fig. 80: Annulus Gear
Courtesy of GENERAL MOTORS CORP.

1. Clean the ring gear in cleaning solvent and air dry.

2. Inspect the ring gear teeth for the following conditions:
 - Damage or excessive wear
 - Chipped
 - Debris embedded in the root of the teeth
3. Replace the ring gear if it is faulty.

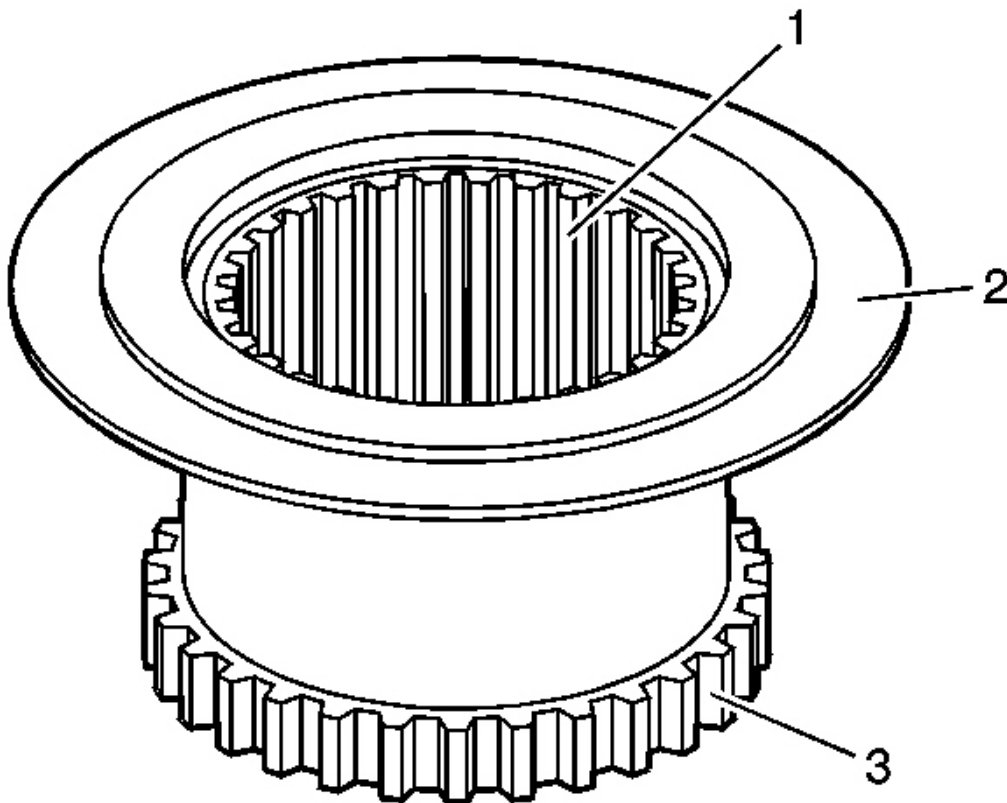

Fig. 81: Identifying High/Low Range Shift Sleeve Inspection Areas
Courtesy of GENERAL MOTORS CORP.

1. Clean the high/low range shift sleeve in cleaning solvent and air dry.
2. Inspect the high/low range shift sleeve for the following conditions:
 - Excessive wear or roughness on the shift fork pad surface (2)
 - Damaged, chipped or excessive wear on the engagement teeth (3)

- Excessive looseness or gouging on the mainshaft splines (1)

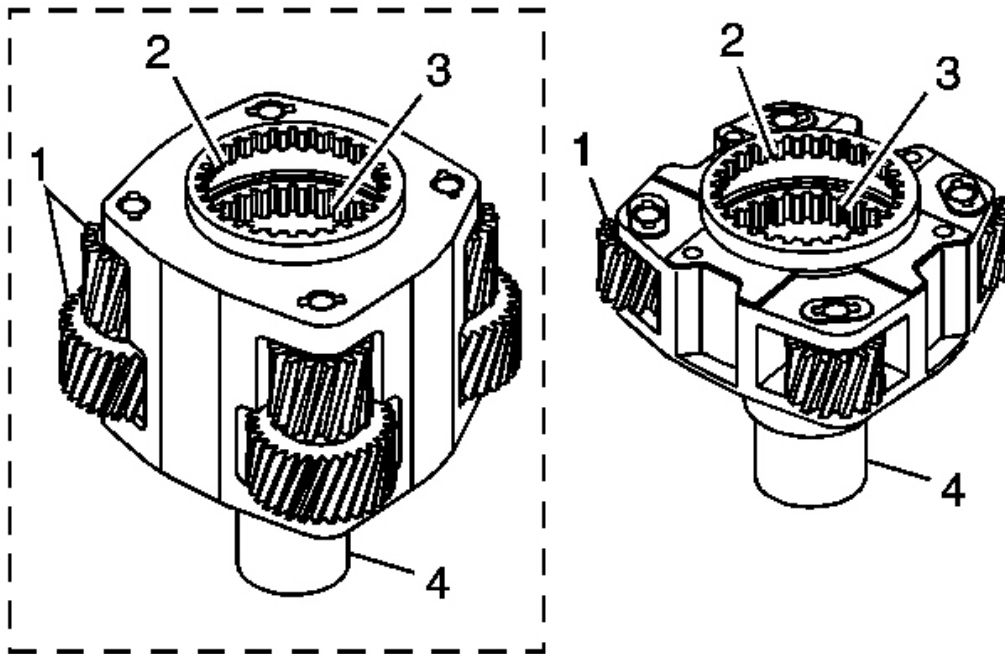

Fig. 82: High/Low Planetary Carrier
Courtesy of GENERAL MOTORS CORP.

1. Clean the high/low planetary carrier in cleaning solvent. Do not disassemble the planetary carrier.
2. Air dry and ensure all cleaning solvent is removed from the bearings in the planetary gears (1). Do not spin the planetary gears with compressed air.
3. Inspect the planetary gears for chipped teeth.
4. Inspect the planetary gears for debris embedded in the root of the teeth.
5. Inspect the planetary gears for excessive side movement from worn bearings, thrust washers or shafts.
6. Inspect the low range teeth (2) for damage or excessive wear.
7. Inspect the high range teeth (3) for damage or excessive wear.
8. Inspect the input seal surface (4) for scoring or excessive wear.
9. Inspect the thrust bearing surface for scoring or excessive wear.

2007 Hummer H3

2007 TRANSMISSION Transfer Case - BW 4493/4494 - H3

10. Replace the high/low planetary carrier if any of the above conditions are found.
11. Inspect the mainshaft front support bearing for the following conditions:
 - Scoring
 - Pitting
 - Brinelling
 - Excessive wear
12. Replace the mainshaft front support bearing if it is faulty. Refer to **Transfer Case Disassemble** and **Transfer Case Assemble**.
13. Inspect the high/low planetary thrust bearing for excessive wear or scoring.
14. Replace the thrust bearing if it is faulty.

Differential Components

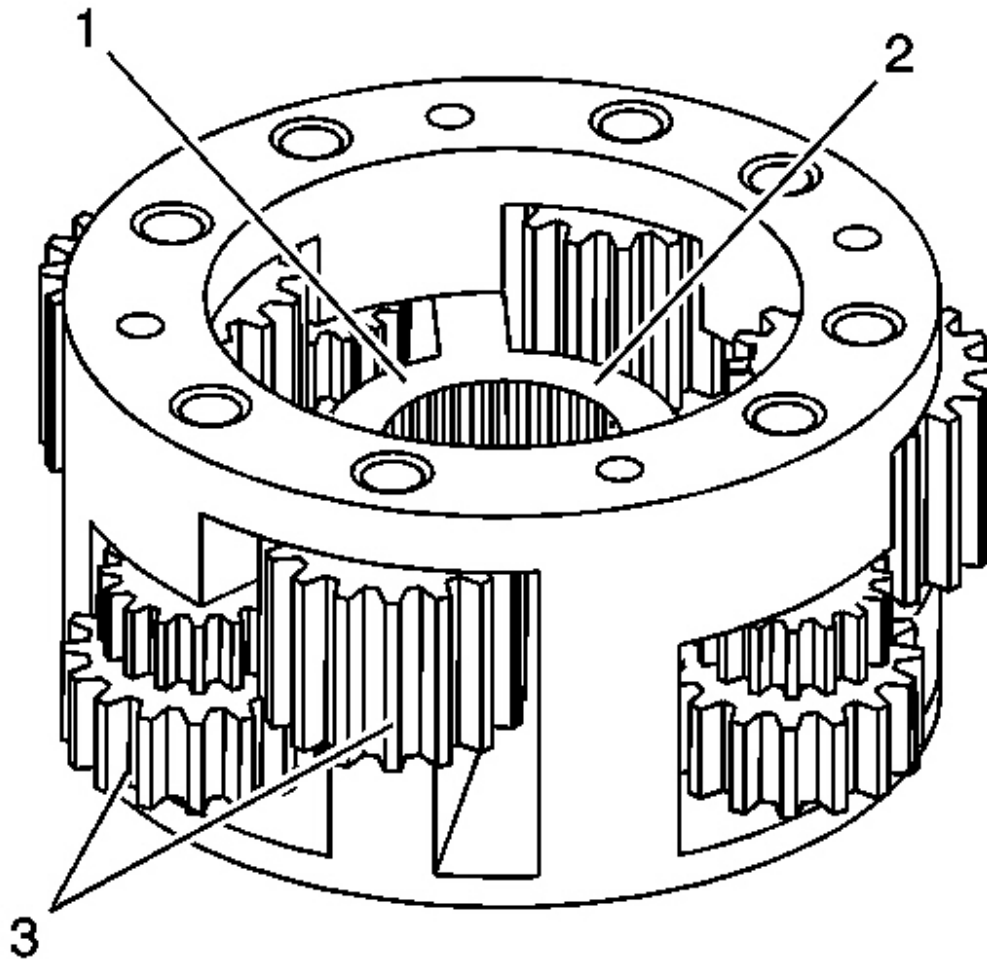

Fig. 83: Inspecting Planetary Differential Components
Courtesy of GENERAL MOTORS CORP.

1. Clean the planetary differential in cleaning solvent. Do not disassemble the planetary differential.
2. Air dry and ensure all cleaning solvent is removed from the bushings in the pinion gears (3). Do not spin the pinion gears with compressed air.
3. Inspect the pinion gears for chipped teeth.
4. Inspect the pinion gears for debris embedded in the root of the teeth.
5. Inspect the pinion gears for excessive side movement from worn bushings, thrust washers or

shafts.

6. Inspect the planetary differential assembly for cracks at the web (1) of the housing.
7. Inspect the thrust washer surface (2) for scoring or excessive wear.
8. Inspect the planetary differential for distortion.
9. Inspect the planetary differential to mainshaft splines for excessive wear.
10. Replace the planetary differential if any of the above conditions are found.
11. Inspect the thrust washer for excessive wear or scoring.
12. Replace the thrust washer if it is faulty.

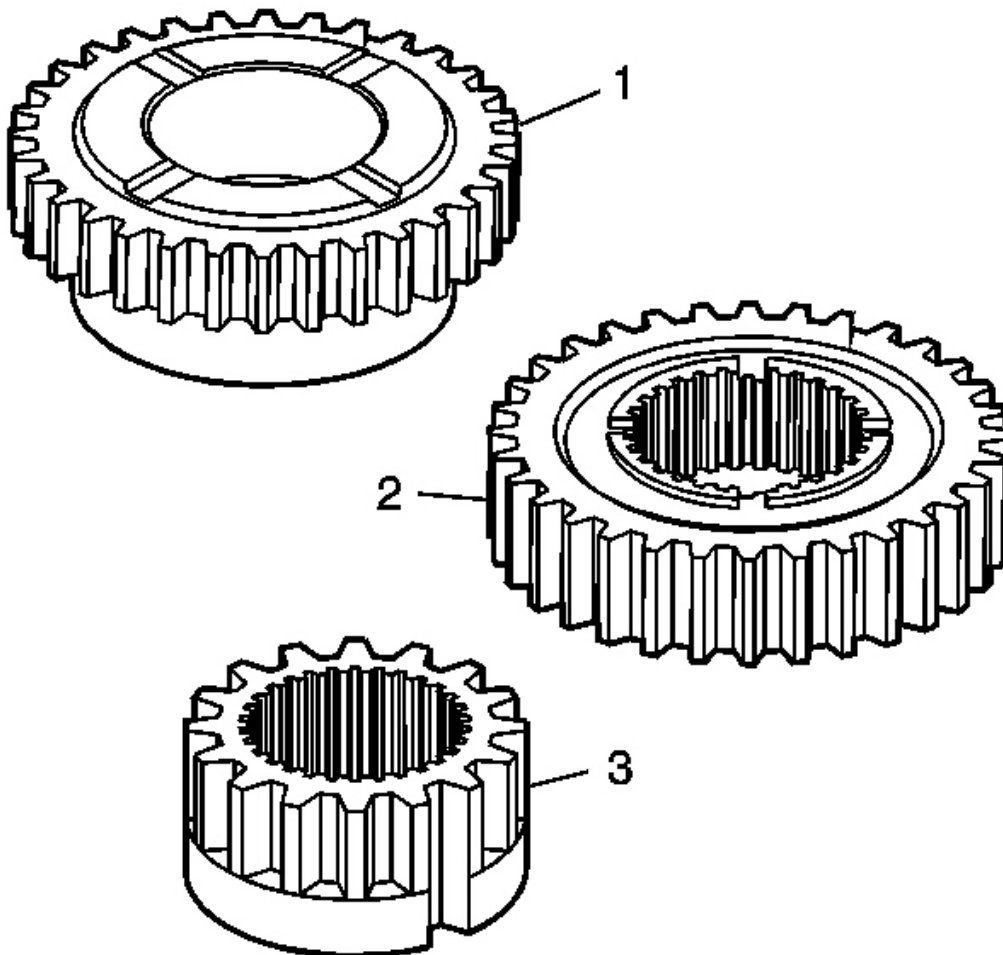

Fig. 84: Front Sun Gear, Rear Sun Gear And Inner Lockup Hub

Courtesy of GENERAL MOTORS CORP.

1. Clean the front sun gear (1), the rear sun gear (2) and the inner lockup hub (3) in cleaning solvent and air dry.
2. Inspect the teeth on the front sun gear (1), the rear sun gear (2) and the inner lockup hub (3) for the following conditions:
 - Chipped teeth
 - Excessively worn gear surfaces

Slight wear marks are normal.

 - Debris embedded in the root of the teeth
3. Inspect the thrust washer surfaces for excessive wear or scoring.
4. Replace the front sun gear (1), the rear sun gear (2) and the inner lockup hub (3) if they are faulty.

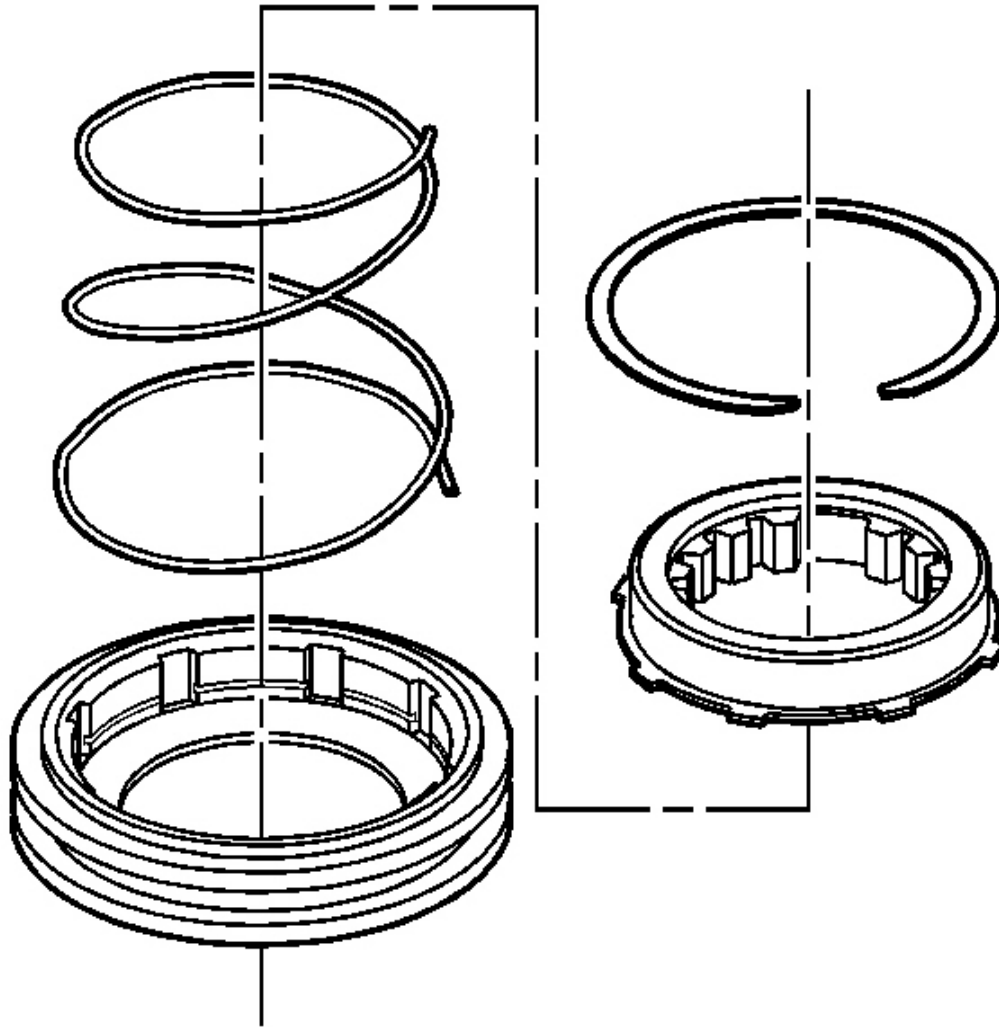

Fig. 85: View Of Lockup Shift Collar Assembly
Courtesy of GENERAL MOTORS CORP.

1. Disassemble the lockup shift collar assembly, if necessary. Refer to **Transfer Case Disassemble** and **Transfer Case Assemble**.
2. Clean the lockup shift collar assembly components in cleaning solvent and air dry.
3. Inspect the lockup shift hub engagement teeth for the following conditions:
 - Chipped teeth

- Excessively worn gear surfaces

Slight wear marks are normal.

- Debris embedded in the root of the teeth
4. Replace the lockup shift collar assembly if it is faulty. The lockup shift collar assembly components are not serviced separately.

Drive Chain and Sprockets

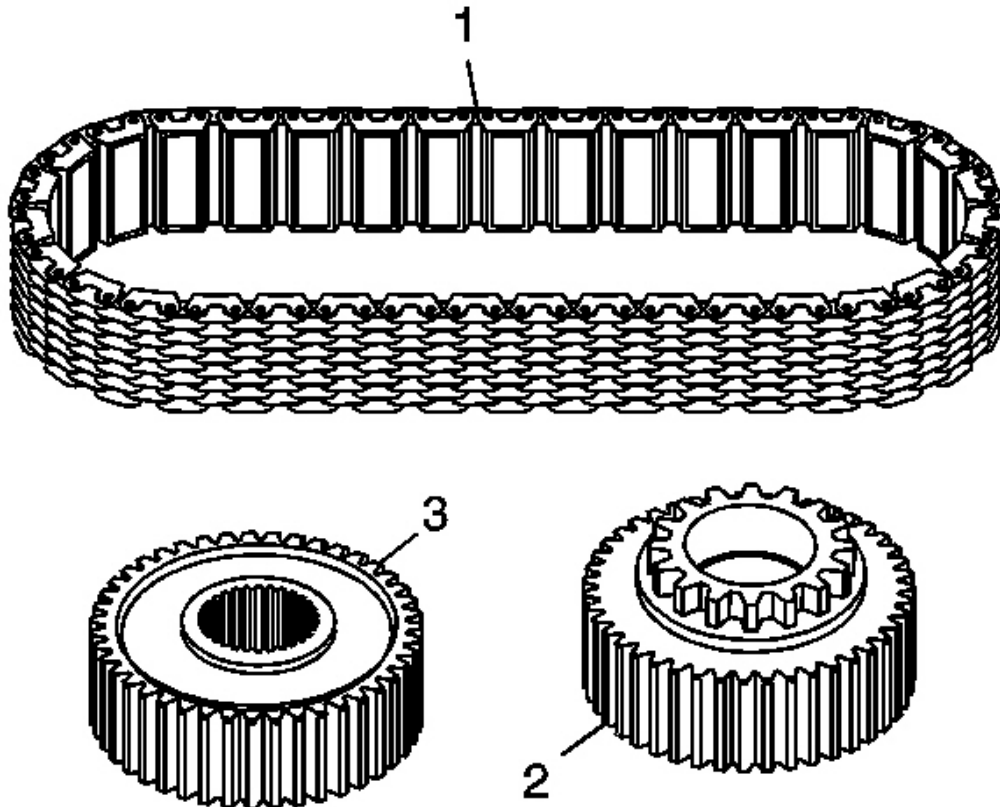

Fig. 86: Drive Chain and Sprockets
Courtesy of GENERAL MOTORS CORP.

1. Clean the drive chain (1), drive sprocket (2) and driven sprocket (3) in cleaning solvent and air dry.

2007 Hummer H3

2007 TRANSMISSION Transfer Case - BW 4493/4494 - H3

2. Inspect the drive chain (1) for the following conditions:
 - Loose link pins
 - Binding or stiff links
 - Debris embedded in the links
 - Worn teeth surfaces
3. Replace the chain if any of the above conditions are found.
4. Inspect the driven sprocket (3) and the drive sprocket (2) for the following conditions:
 - Chipped teeth
 - Excessively worn gear surfaces

Slight wear marks are normal.

 - Debris embedded in the root of the teeth
5. Inspect the drive sprocket (2) for the following conditions:
 - Lockup shift engagement teeth for chipping
 - Lockup shift engagement teeth for excessive wear
6. Inspect the drive sprocket bushing for the following conditions:
 - Excessive wear
 - Scoring
7. Replace the sprockets if any of the above conditions are found. The chain and sprockets may be replaced separately.

Mainshaft

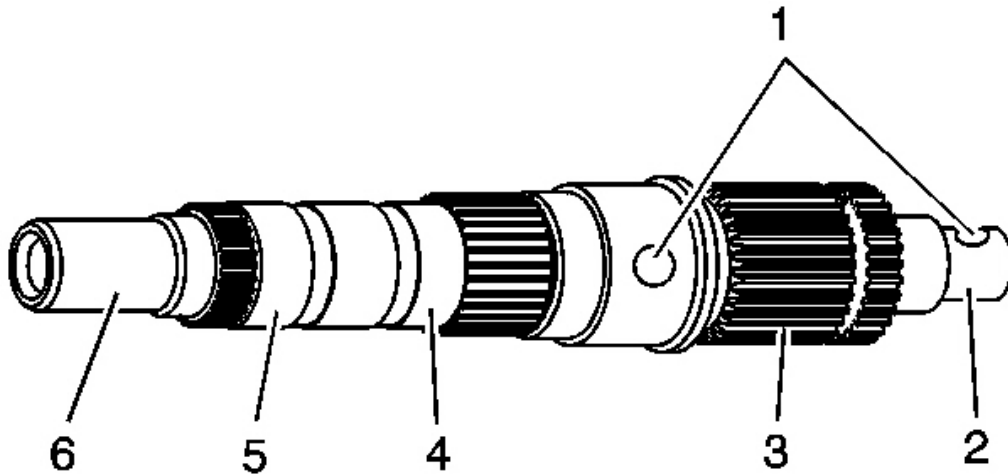

Fig. 87: Mainshaft

Courtesy of GENERAL MOTORS CORP.

1. Clean the mainshaft in cleaning solvent.
2. Clean the mainshaft oil galleries (1) and air dry.

IMPORTANT: Do not attempt to smooth any roughness in the bearing journals.

3. Inspect the front support bearing (2), drive gear bushing (4), front output sun gear (5) and the rear support bushing (6) bearing journals on the mainshaft for the following conditions:
 - Scoring
 - Pitting
 - Brinelling
 - Excessive wear
4. Inspect the mainshaft range collar splines (3) for damage or excessive wear. Witness marks at the location of the gear is normal.
5. Replace the mainshaft if any of the above conditions are found.

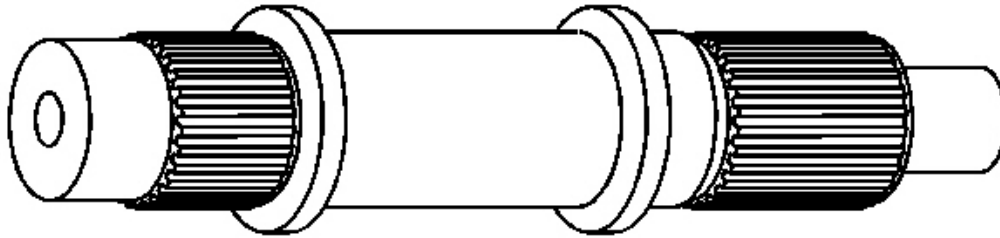

Fig. 88: Front Output Shaft
Courtesy of GENERAL MOTORS CORP.

1. Clean the front output shaft in cleaning solvent and air dry.
2. Inspect for spun bearings at the front output shaft bearing areas.
3. Inspect the front output internal splines and driven gear splines for damage or excessive wear.
4. Replace the front output shaft if it is damaged.

Rear Output Shaft

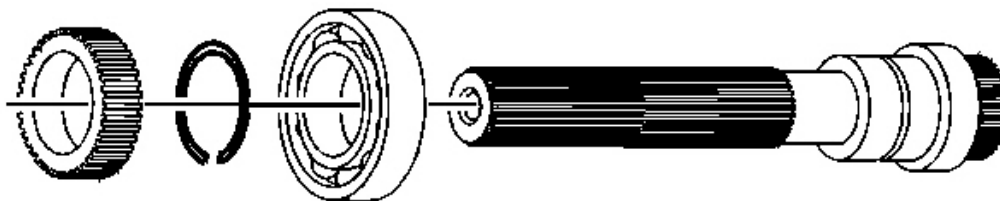

Fig. 89: Rear Output Shaft
Courtesy of GENERAL MOTORS CORP.

1. Clean the rear output shaft, with rear output shaft bearing, in cleaning solvent.
2. Air dry and ensure all solvent is removed from the bearing.
3. Inspect the speed sensor tone wheel for damage.

4. Replace the speed sensor tone wheel if it is faulty. Refer to **Transfer Case Disassemble** and **Transfer Case Assemble**.
5. Inspect the rear output shaft bearing for the following conditions:
 - Scoring
 - Pitting
 - Brinelling
 - Excessive wear
6. Replace the rear output shaft bearing if it is faulty. Refer to **Transfer Case Disassemble** and **Transfer Case Assemble**.
7. Inspect the mainshaft rear support bushing for the following conditions:
 - Pitted
 - Wear
 - Corrosion
8. Replace the mainshaft rear support bushing if any of the above conditions are found. Refer to **Transfer Case Disassemble** and **Transfer Case Assemble**.
9. Inspect the rear output shaft splines for wear or damage.
10. Inspect the rear output shaft bearing area for a spun bearing.
11. Replace the rear output shaft if any of the above conditions are found.

Shift System Components

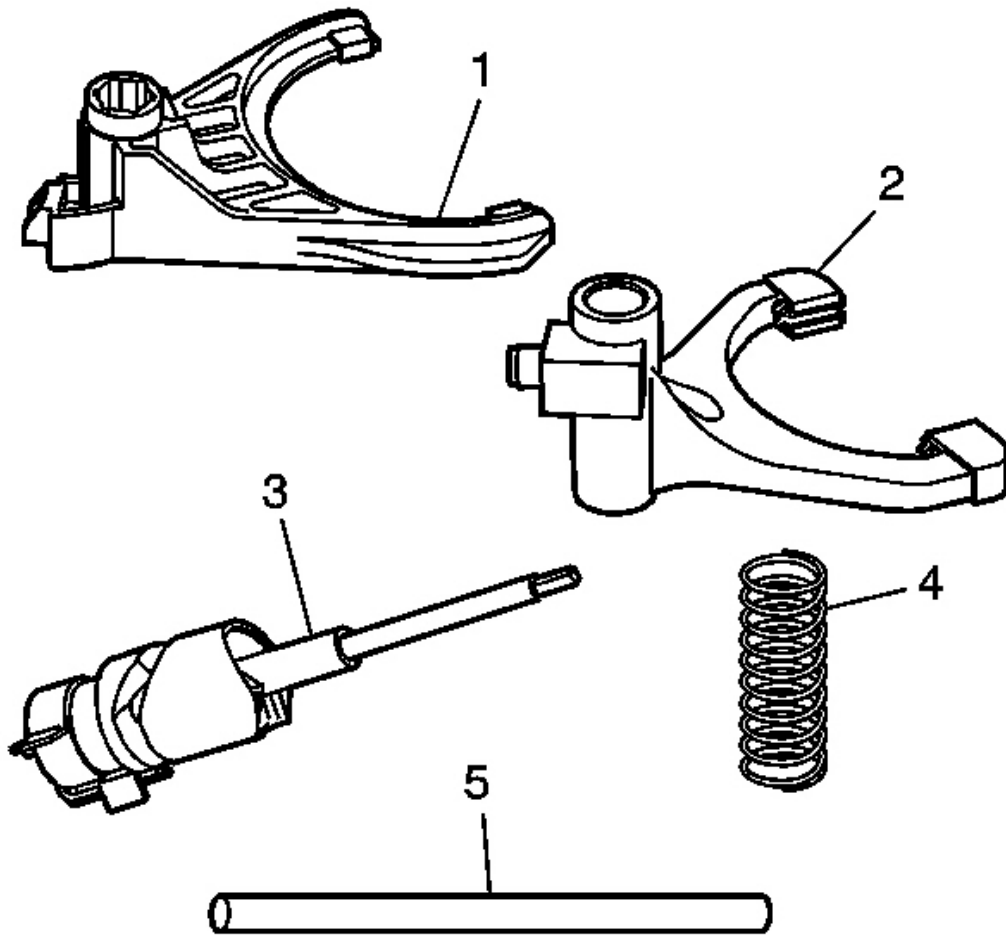

Fig. 90: Shift System Components
Courtesy of GENERAL MOTORS CORP.

1. Clean the following shift system components in cleaning solvent and air dry.
 - The lockup mode shift fork (1)
 - The high/low range shift fork (2)
 - The shift cam and shaft assembly (3)
 - The shift fork spring (4)
 - The shift fork shaft (5)
2. Inspect the shift fork shaft (5) for straightness and excessive wear at the shift fork locations.

3. Replace the shift fork shaft if it is not straight or if it is worn excessively.

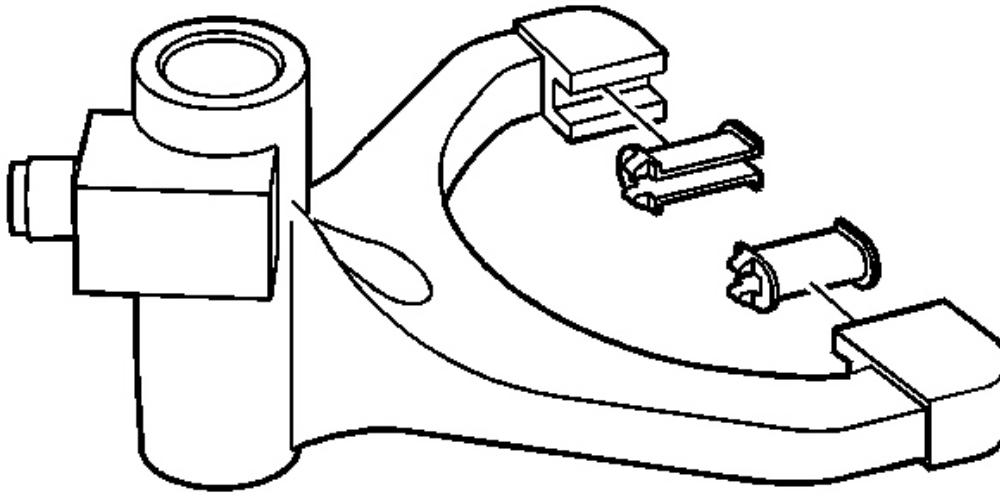

Fig. 91: Pads On High/Low Range Shift Fork
Courtesy of GENERAL MOTORS CORP.

1. Inspect the pads on the high/low range shift fork for wear.
2. Replace worn pads.
3. Inspect the roller on the shift fork for wear.
4. Inspect the bore for the shift fork shaft for excessive wear.
5. Replace the shift fork if the above conditions are found.

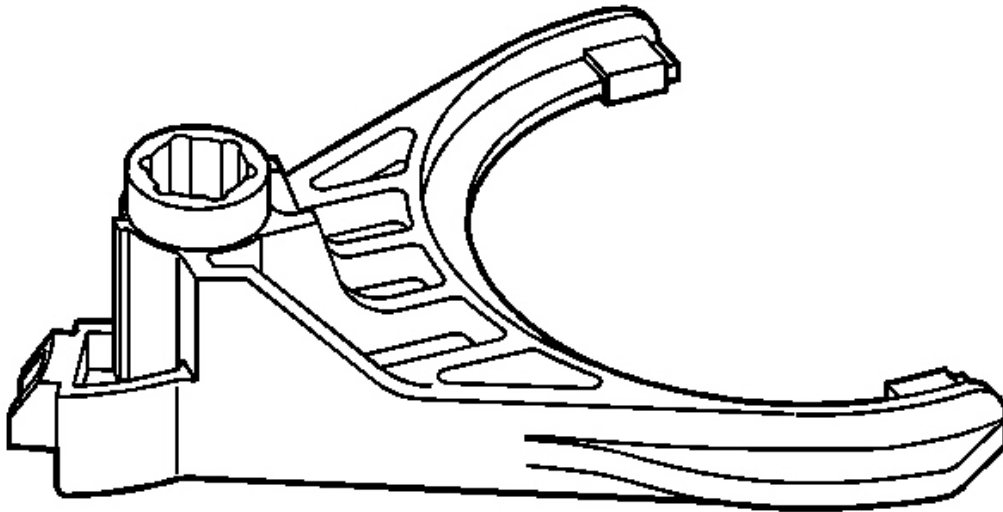

Fig. 92: Lockup Mode Shift Fork
Courtesy of GENERAL MOTORS CORP.

1. Inspect the lockup mode shift fork for excessive wear at the lockup collar pads.
2. Inspect the lockup mode shift fork for wear at the shift detent cam follower.
3. Inspect the lockup mode shift fork for cracks.
4. Replace the lockup mode shift fork if any of the above conditions are found.

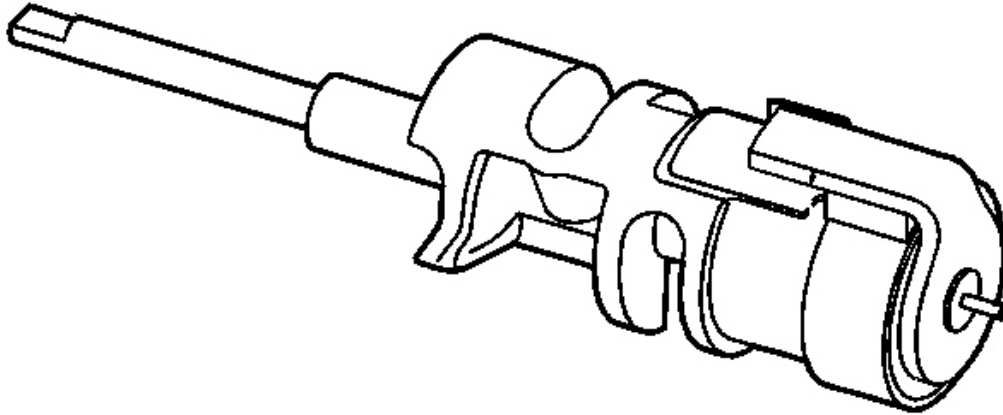

Fig. 93: Shift Cam And Shaft Assembly
Courtesy of GENERAL MOTORS CORP.

IMPORTANT: Only disassemble the shift cam and shaft assembly if replacing a faulty component. The tip on the end of the shift cam shaft is used for assembly. If the tip is broken off, the shaft can still be used, but may cause problems aligning with the rear case half during the assembly procedure.

1. Inspect the shift cam surfaces for the following conditions:
 - Roughness
 - Grooves
 - Excessive wear
2. Inspect the shift cam shaft for the following conditions:
 - Encoder motor drive end excessively worn
 - Straightness
3. Inspect the spring for being weak or the tabs bent.
4. Replace any of the above components if they are found to be faulty.

TRANSFER CASE ASSEMBLE

Tools Required

2007 Hummer H3

2007 TRANSMISSION Transfer Case - BW 4493/4494 - H3

- **DT-47847** Front Output Shaft Seal Installer. See **Special Tools**.
- **DT-47946** Bearing Installer. See **Special Tools**.
- **J 3289-20** Holding Fixture
- **J 8614-01** Flange and Pulley Holding Tool
- **J 22912-B** Rear Pinion and Axle Bearing Remover
- **J 36850** Transjel Lubricant
- **J 42176** Universal Driver Handle - Non-Threaded. See **Special Tools**.
- **J 42738** Seal Installer. See **Special Tools**.
- **J 45380** Transfer Case Rear Bushing Remover and Installer. See **Special Tools**.
- **J 45756** Rear Output Shaft Seal Installer. See **Special Tools**.
- **J 45757** Mainshaft Support Bushing and Bearing Installer. See **Special Tools**.
- **J 45759** Assembly Fixture. See **Special Tools**.

Assembly Procedure

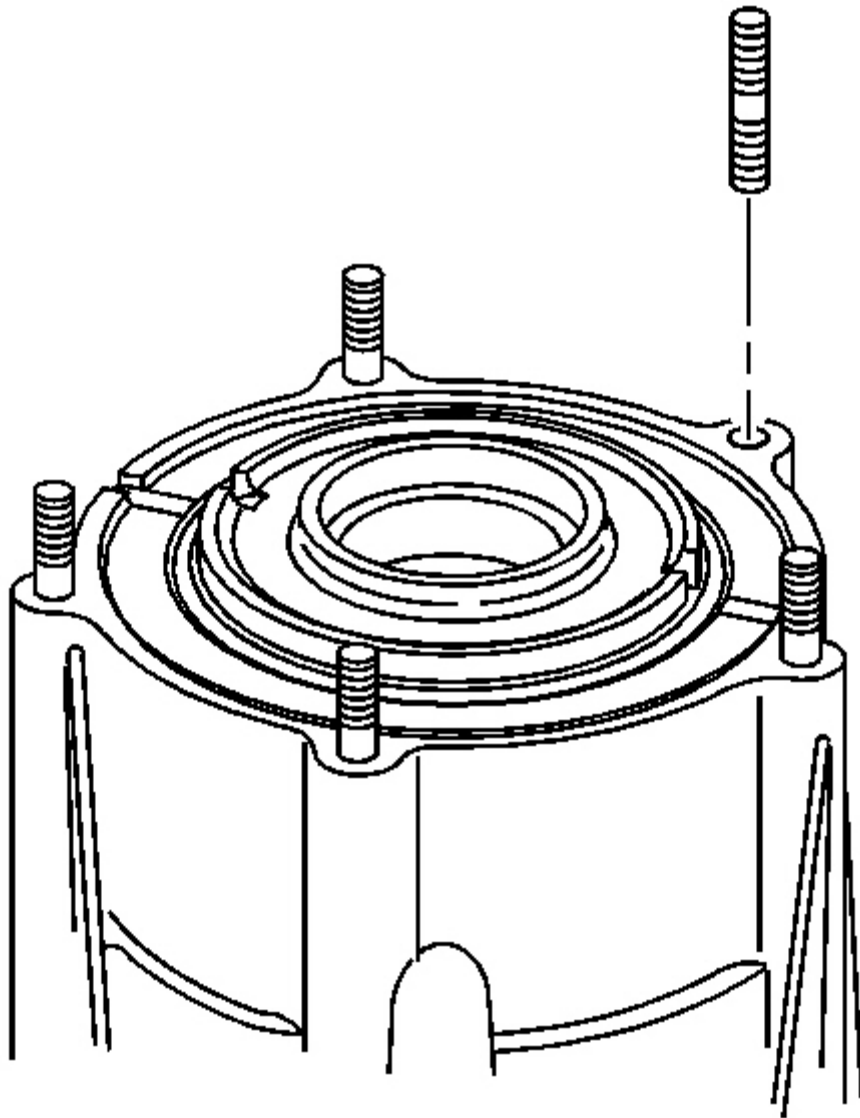

Fig. 94: Transfer Case Mounting Studs
Courtesy of GENERAL MOTORS CORP.

NOTE: Refer to Fastener Notice .

1. If removed, install the transfer case mounting studs.

Tighten: Tighten the adapter studs to 14 N.m (10 lb ft).

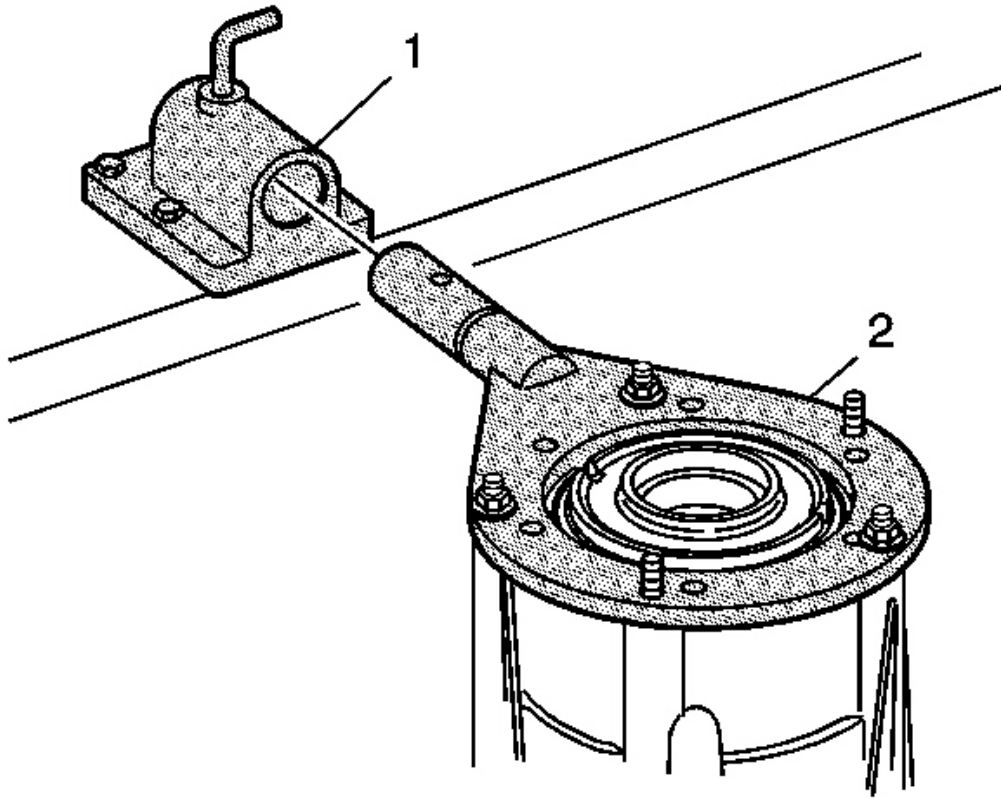

Fig. 95: J 45759 And J 3289-20 Mounted On Workbench
Courtesy of GENERAL MOTORS CORP.

2. Using the adapter studs, attach the **J 45759** to the front transfer case. See **Special Tools**. All of the assembly procedures can be performed with the case mounted to the **J 45759** . See **Special Tools**.
3. Install the **J 45759** (2) into the **J 3289-20** (1) and secure with the pivot pin. See **Special Tools**.

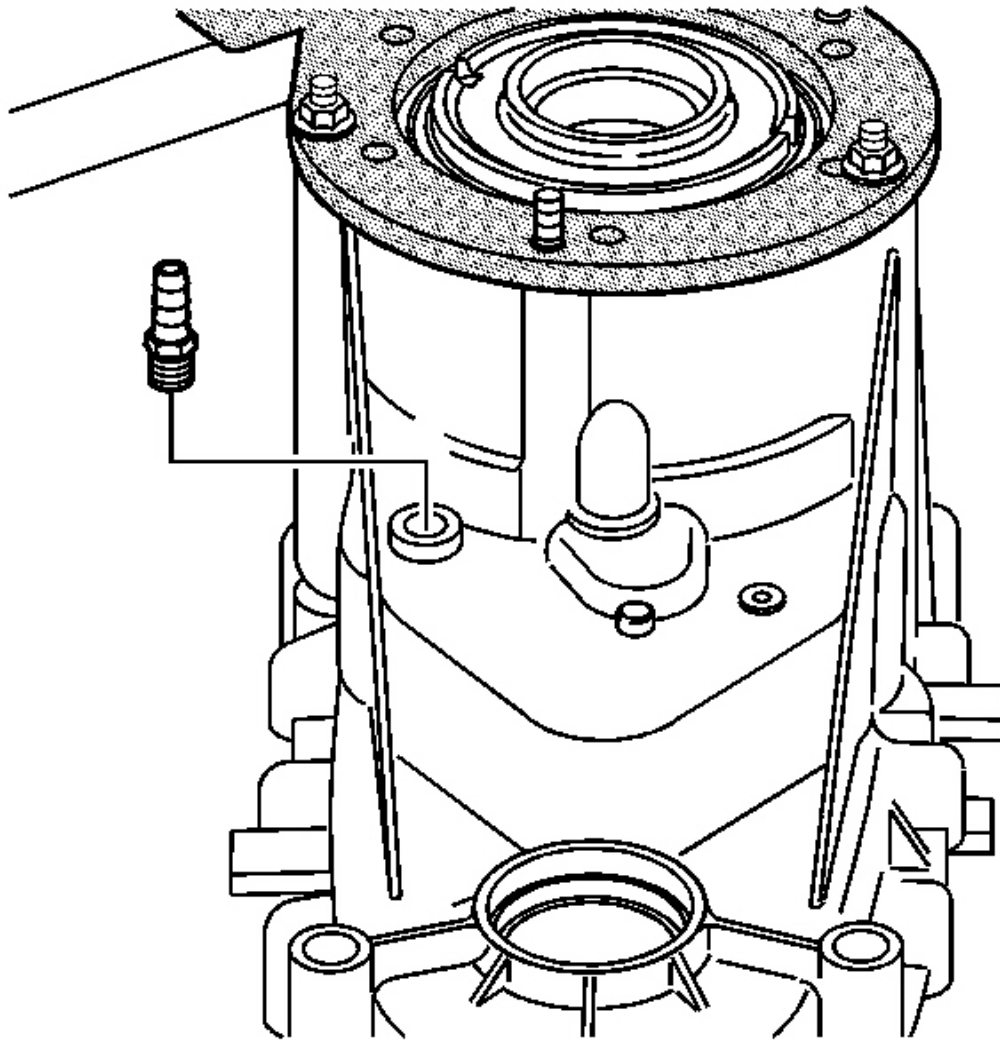

Fig. 96: Locating Front Case Half Vent
Courtesy of GENERAL MOTORS CORP.

4. If the vent is removed, apply pipe sealant GM P/N 12346004 (Canadian P/N 10953480) to the threads on the vent.
5. Install the vent.

Tighten: Tighten the vent to 6 N.m (53 lb in).

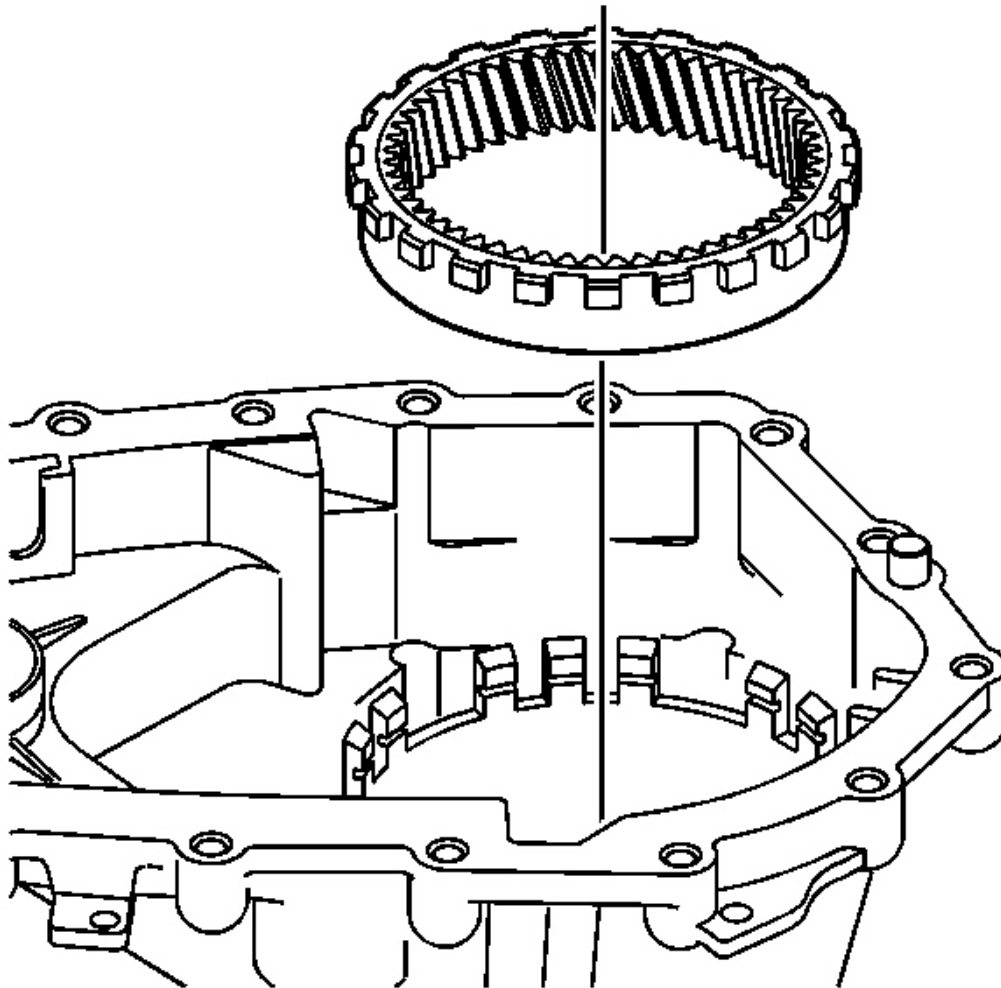

Fig. 97: Identifying Ring Gear At Front Case Half
Courtesy of GENERAL MOTORS CORP.

6. Install the ring gear in the front case half.

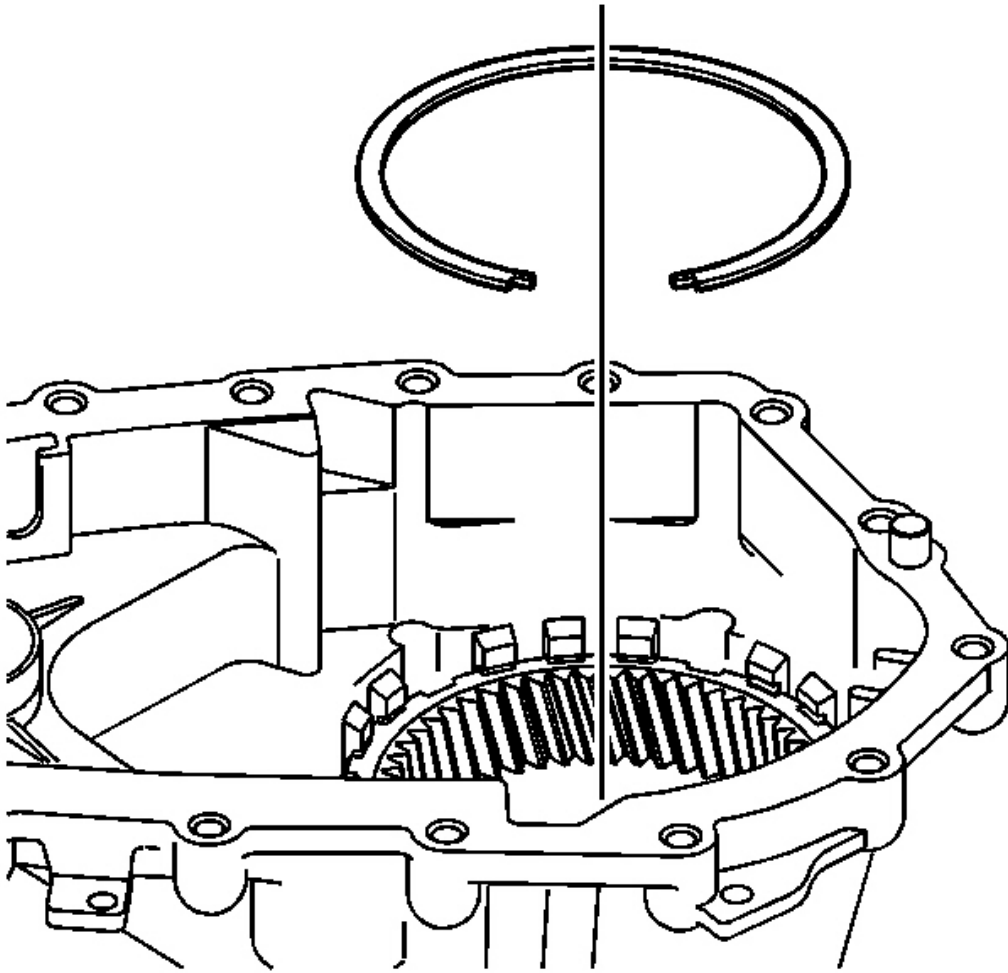

Fig. 98: Identifying Ring Gear Retaining Ring
Courtesy of GENERAL MOTORS CORP.

7. Install a NEW ring gear retaining ring.

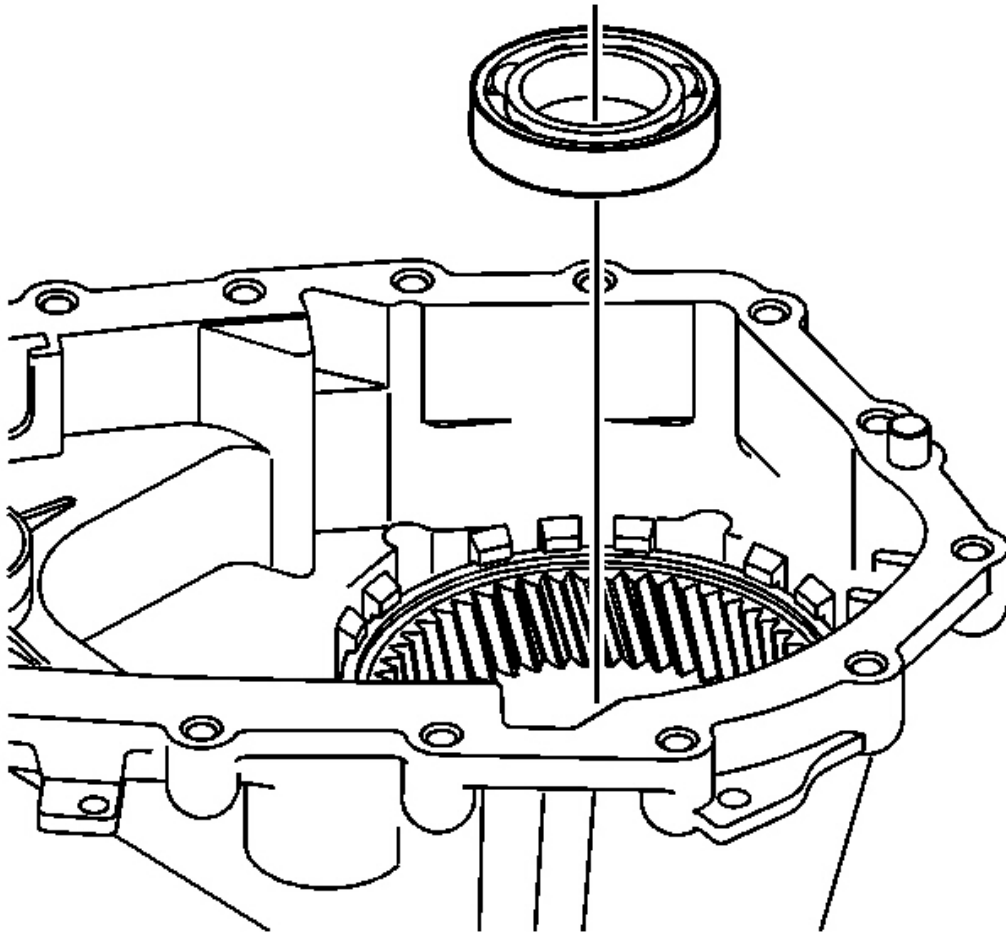

Fig. 99: Input Shaft Bearing
Courtesy of GENERAL MOTORS CORP.

IMPORTANT: Lubricate all of the bearings and bearing journals with transfer case fluid during installation.

8. Install the input shaft bearing in the front case half.
 - Use a hammer and a brass drift only on the outer bearing race.
 - Ensure the bearing is kept square to the bore while installing.

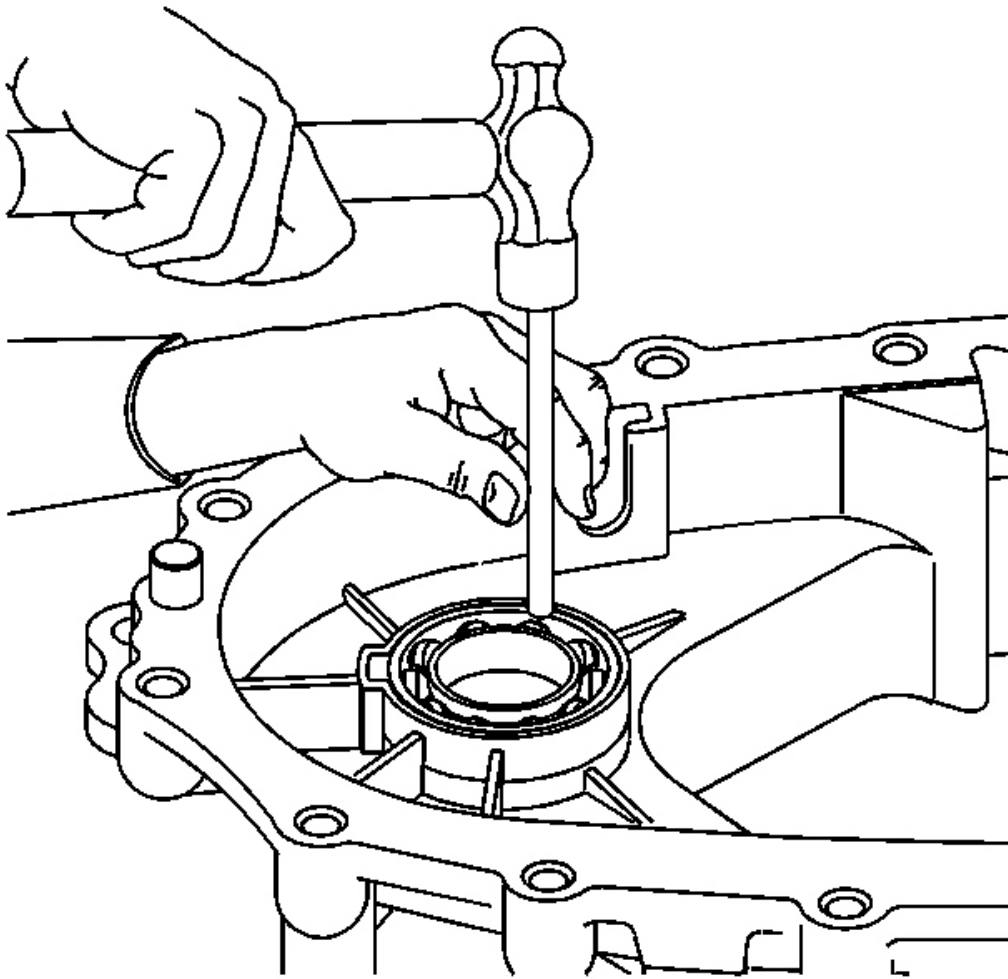

Fig. 100: Installing Front Output Shaft Front Bearing
Courtesy of GENERAL MOTORS CORP.

9. Install the front output shaft front bearing in the front case half.
 - Use a hammer and a brass drift only on the outer bearing race.
 - Ensure the bearing is kept square to the bore while installing.

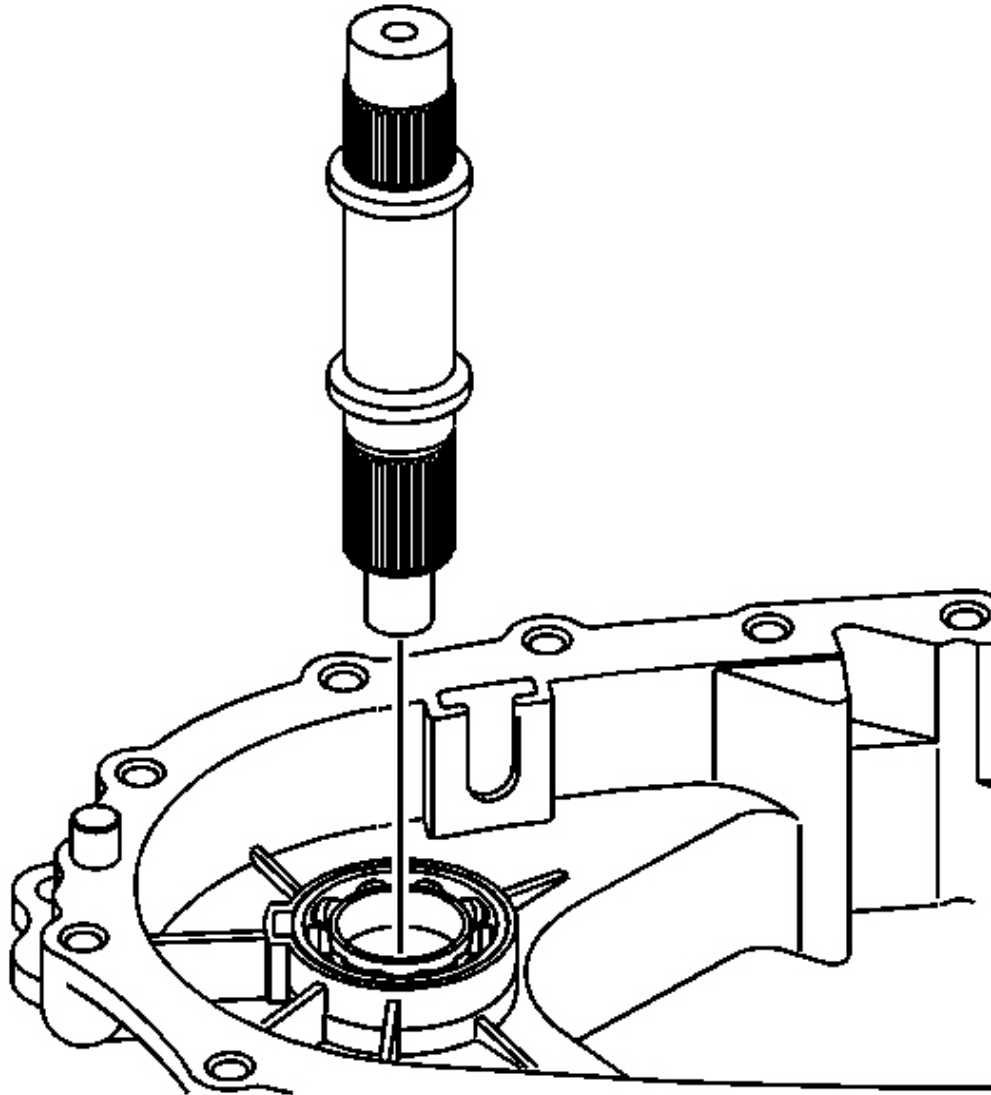

Fig. 101: Removing/Installing Front Output Shaft Assembly
Courtesy of GENERAL MOTORS CORP.

10. Install the front output shaft.

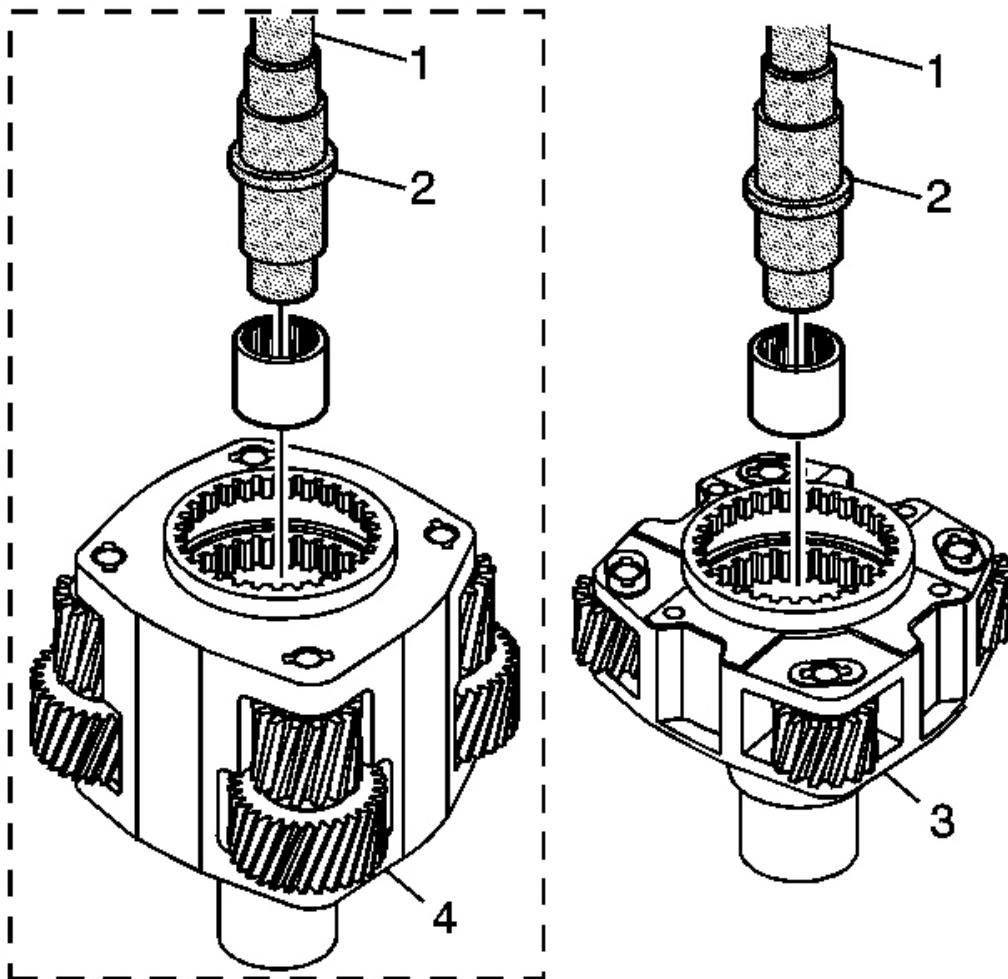

Fig. 102: Installing Mainshaft Front Support Bearing In High/Low Planetary Carrier Assembly

Courtesy of GENERAL MOTORS CORP.

IMPORTANT: DT-47946 is a double ended tool. See Special Tools. In order to install the mainshaft front support bearing to the proper depth, ensure the correct end of the DT-47946 is used. See Special Tools.

For the BW 4493 planetary carrier, the short reach end of the tool is used.

For the BW 4494 planetary carrier, the long reach end of the

tool is used.

- Using the **J 42176** (1) and the **DT-47946** (2), install the mainshaft front support bearing in the high/low planetary carrier assembly model 4493 (3) or 4494 (4). See **Special Tools**.

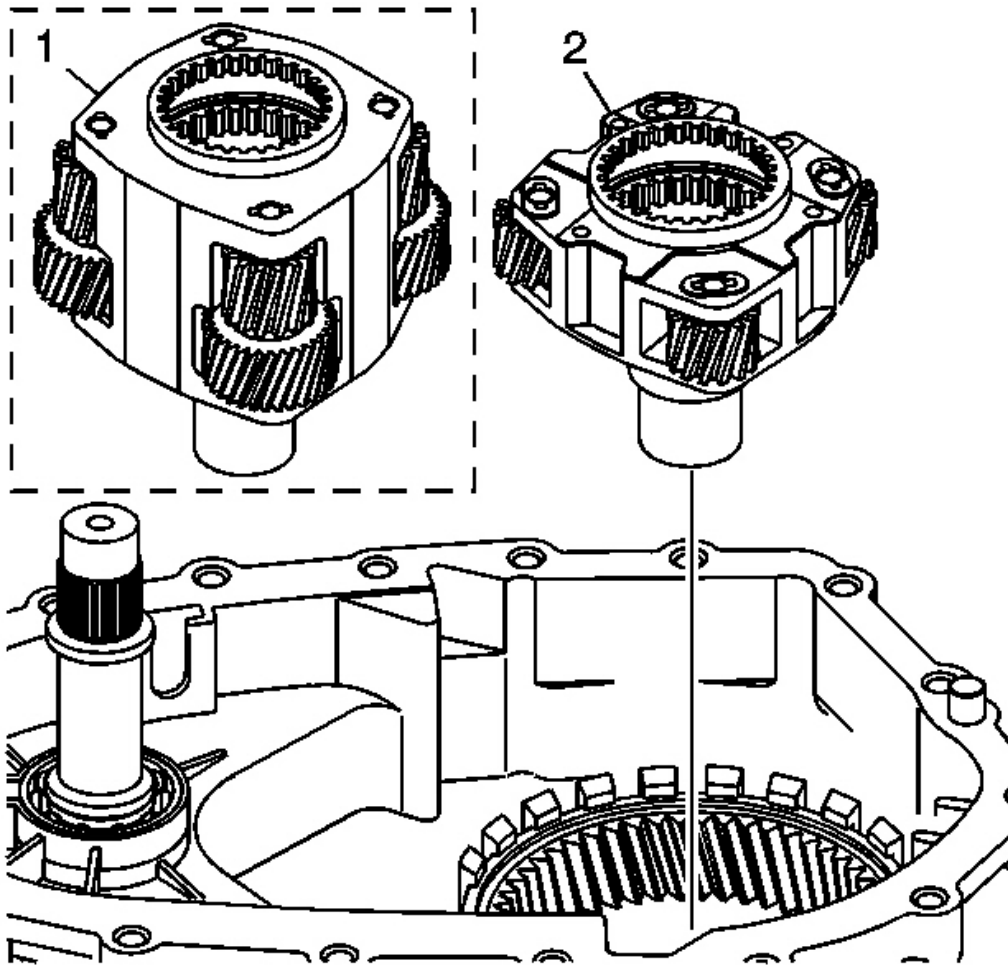

Fig. 103: View Of High/Low Planetary Carrier
Courtesy of GENERAL MOTORS CORP.

- Install the high/low planetary carrier assembly model 4494 (1) or 4493 (2).

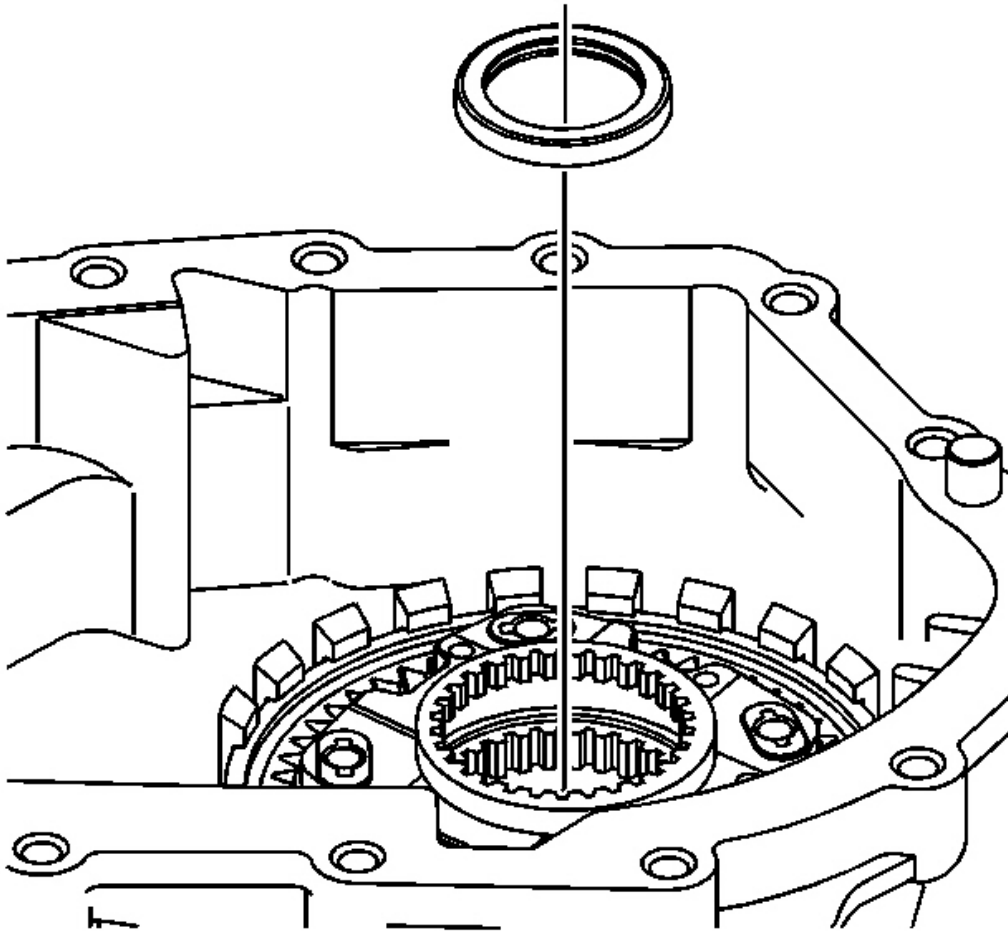

Fig. 104: Locating Input Shaft Needle Thrust Bearing
Courtesy of GENERAL MOTORS CORP.

13. Lubricate the input shaft needle thrust bearing with **J 36850** or equivalent.
14. Install the input shaft thrust bearing.

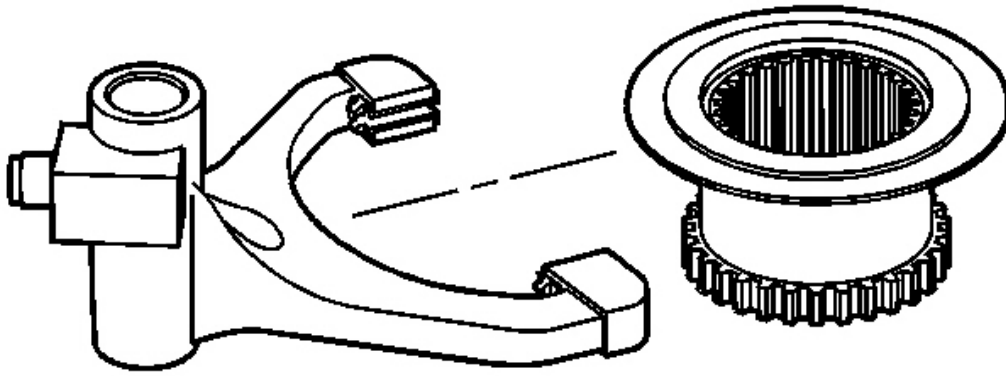

Fig. 105: View Of Range Shift Fork & Range Shift Sleeve
Courtesy of GENERAL MOTORS CORP.

15. Install new shift fork pads, if removed.
16. Install the high/low range sleeve in the high/low range fork.

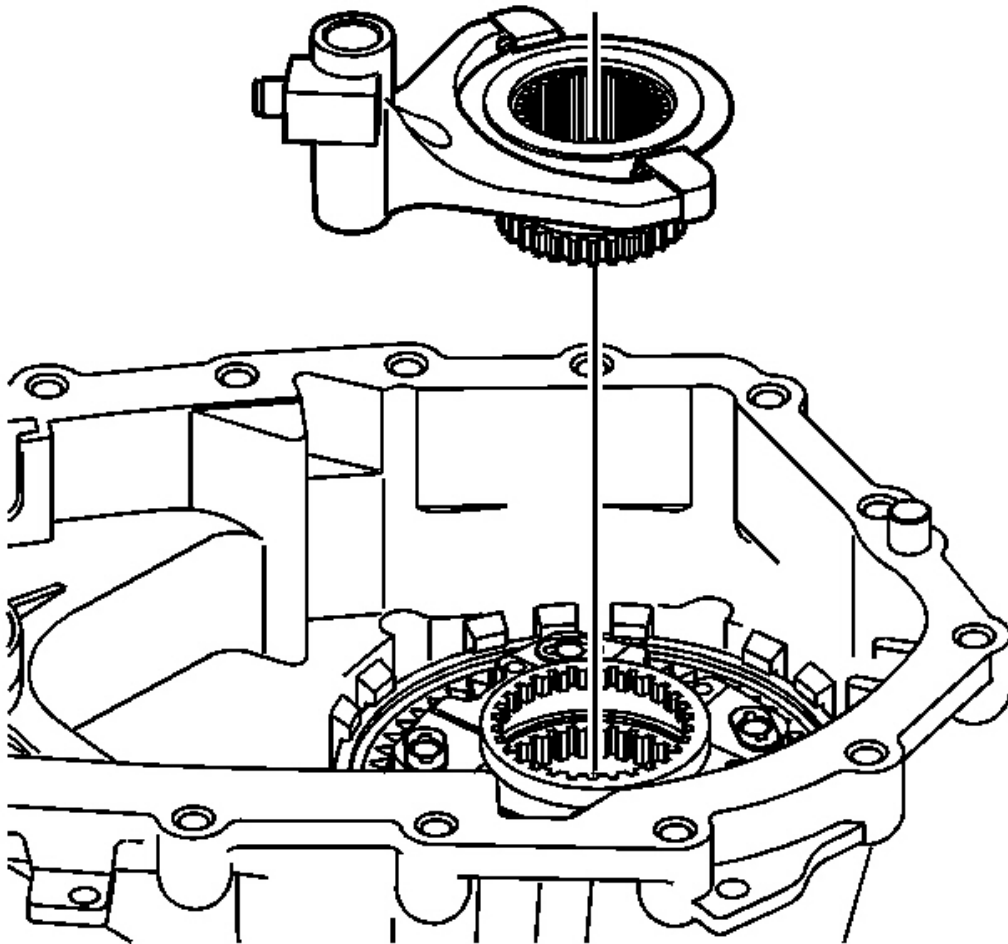

Fig. 106: View Of High/Low Range Sleeve With High/Low Range Shift Fork
Courtesy of GENERAL MOTORS CORP.

17. Align the gear teeth on the high/low range shift sleeve to the high/low planetary carrier.
18. Install the high/low range shift fork and the high/low range sleeve.

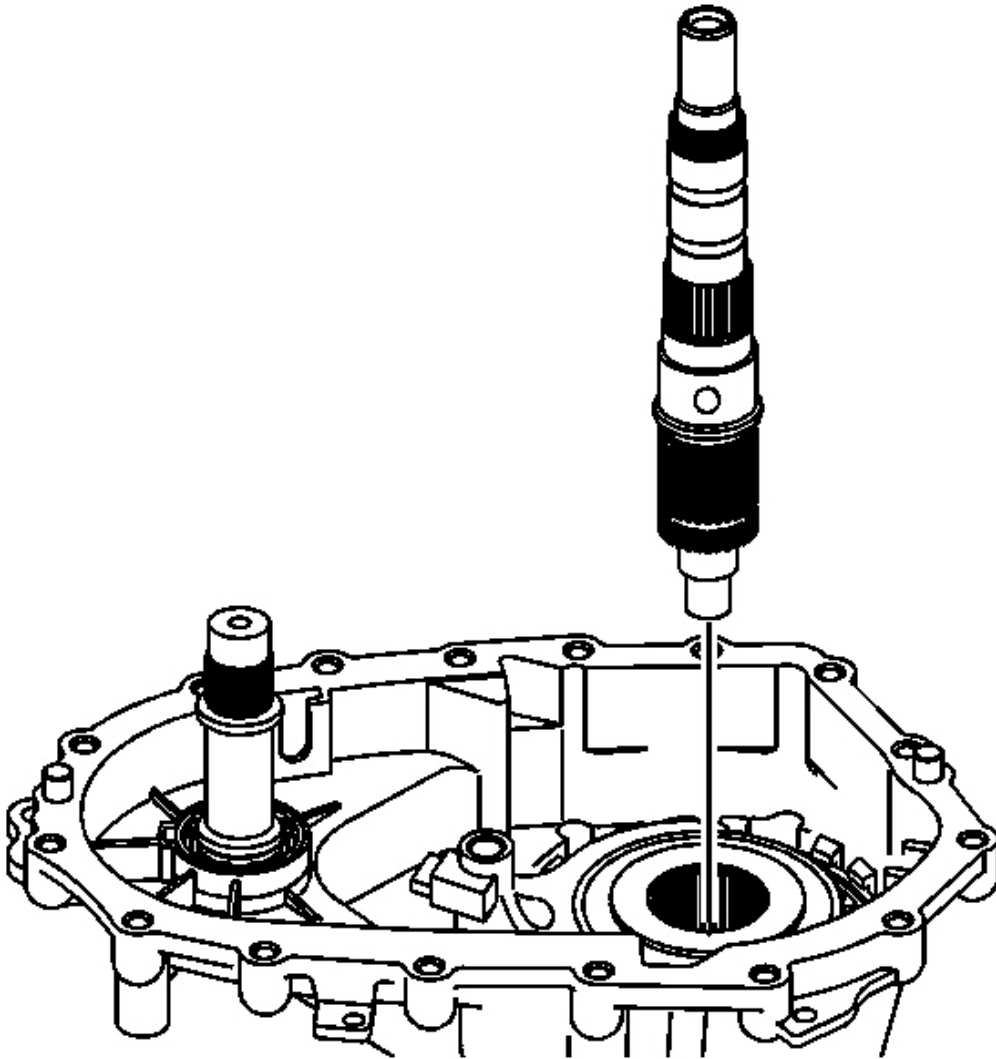

Fig. 107: Identifying Mainshaft
Courtesy of GENERAL MOTORS CORP.

19. Install the mainshaft.

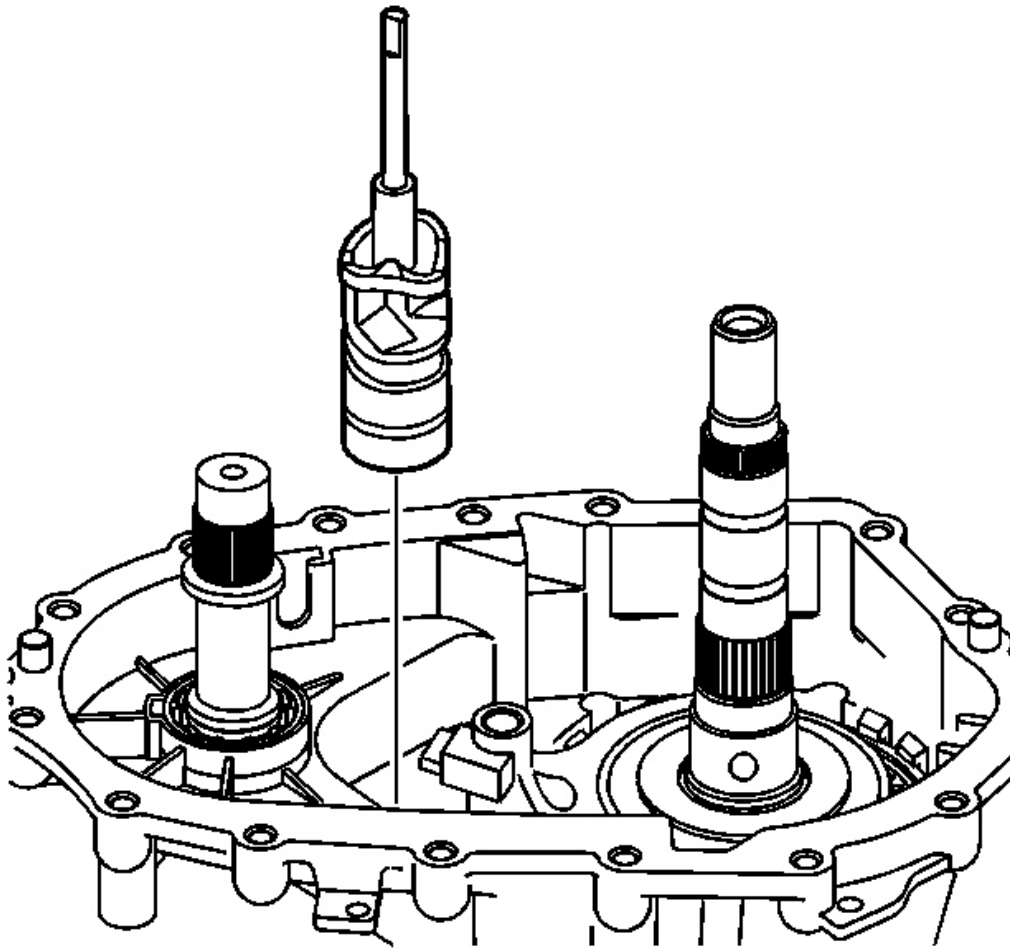

Fig. 108: Identifying Shift Cam And Shaft Assembly
Courtesy of GENERAL MOTORS CORP.

NOTE: In order to prevent component damage, properly remove and install the shift cam and shaft assembly. When removing or installing the shift cam and shaft assembly, keep the shaft straight and do not tilt. Tilting the shift cam and shaft assembly in the transfer case housing will break the tip on the end of the shaft.

20. Install the shift cam and shaft assembly.

1. Install the shift cam and shaft assembly straight, with the tip into the hole in the case.
2. Rotate the high/low range shift fork to position the shift fork roller in the shift cam slot.

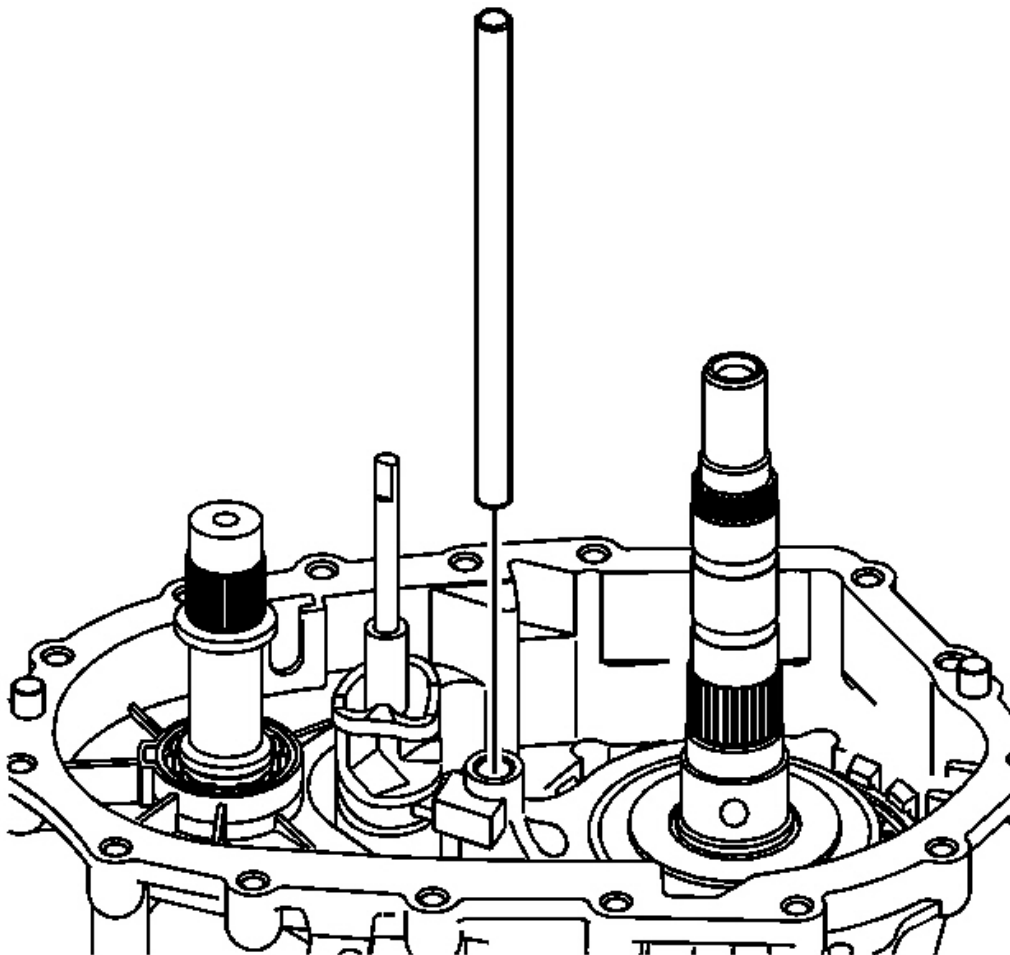

Fig. 109: Identifying Shift Fork Shaft
Courtesy of GENERAL MOTORS CORP.

21. Install the shift fork shaft.

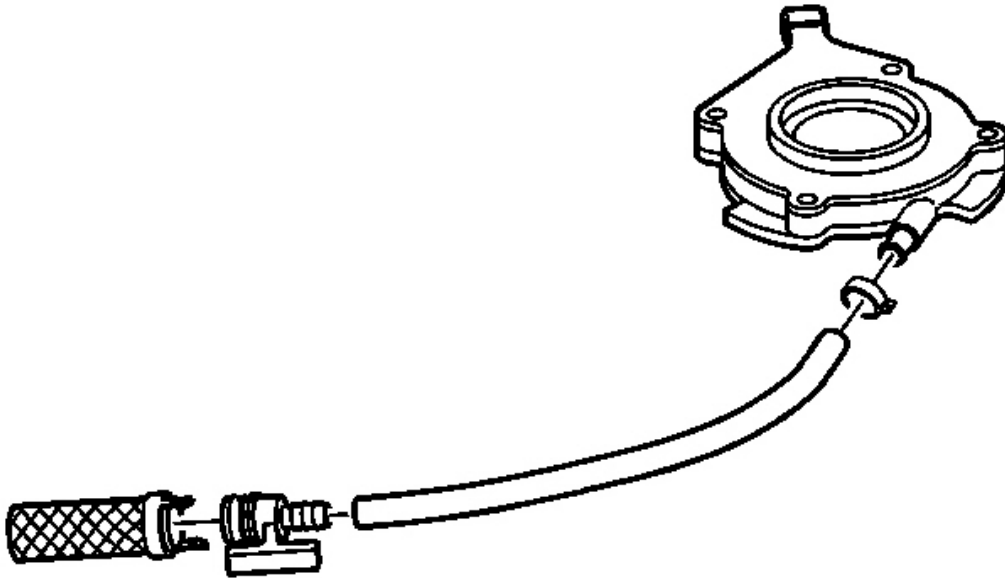

Fig. 110: Oil Pump, Hose & Oil Pump Screen
Courtesy of GENERAL MOTORS CORP.

22. Connect the oil pump hose to the oil pump screen.
23. Connect the oil pump hose to the oil pump.

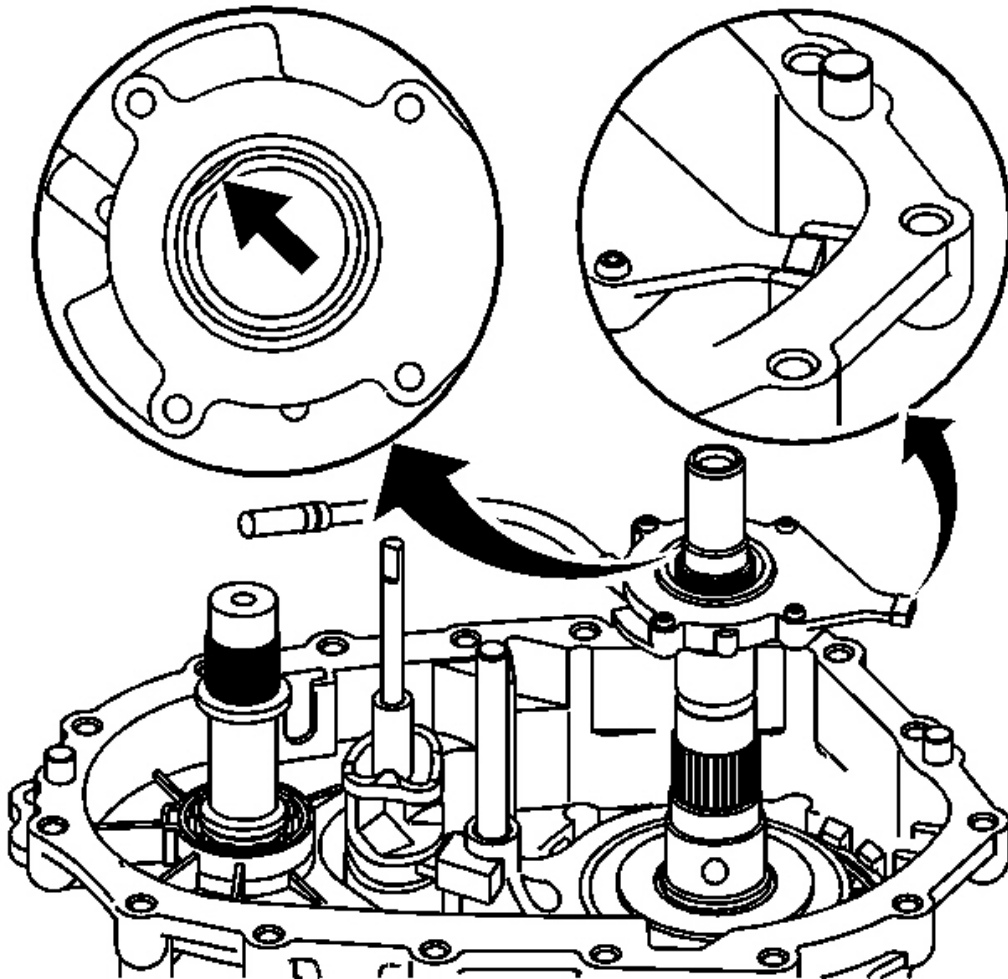

Fig. 111: Identifying Oil Pump Assembly With Hose & Screen
Courtesy of GENERAL MOTORS CORP.

24. Install the oil pump assembly with the hose and screen.
 1. Align the square boss of the oil pump gear with the flat area on the mainshaft.
 2. Install the oil pump in the slot of the front case half. Ensure the wear clip is on the oil pump.
 3. Install the oil pump screen in the front case half.

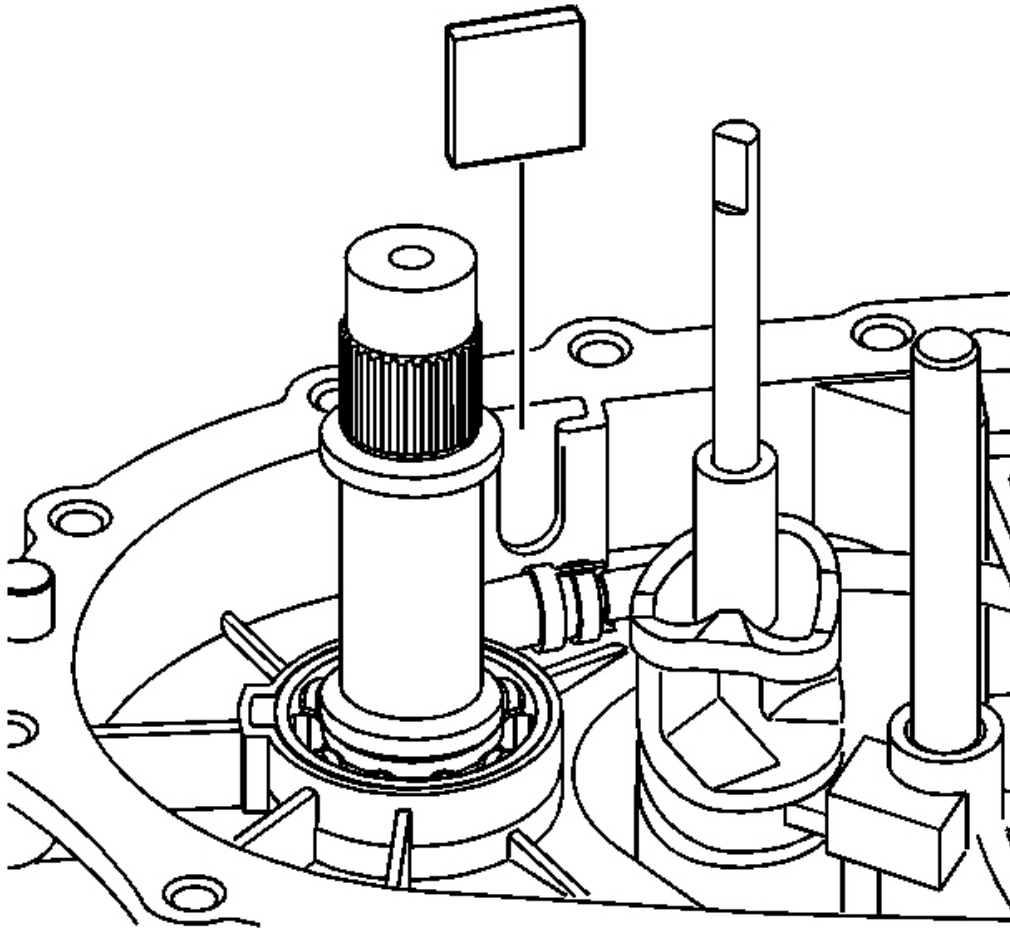

Fig. 112: Locating Magnet
Courtesy of GENERAL MOTORS CORP.

25. Install the magnet.

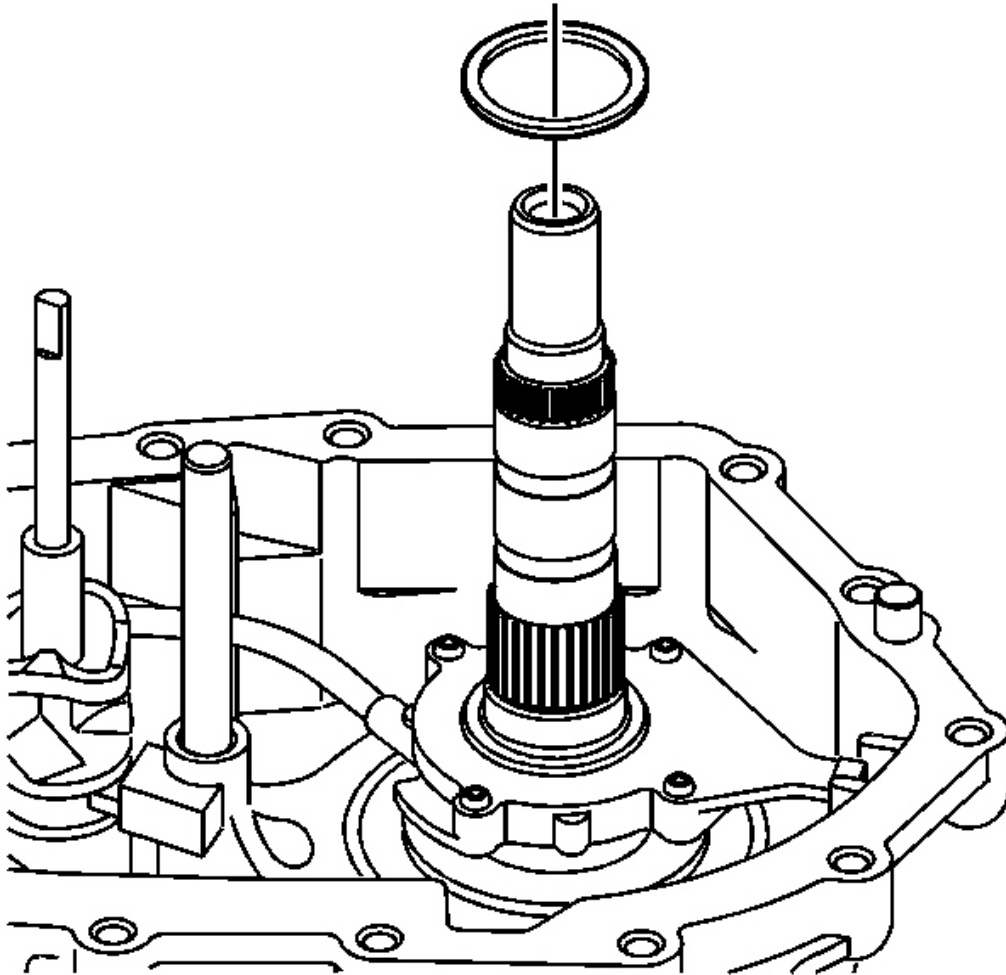

Fig. 113: Identifying Lower Thrust Washer
Courtesy of GENERAL MOTORS CORP.

26. Install the lower center support bearing thrust washer.

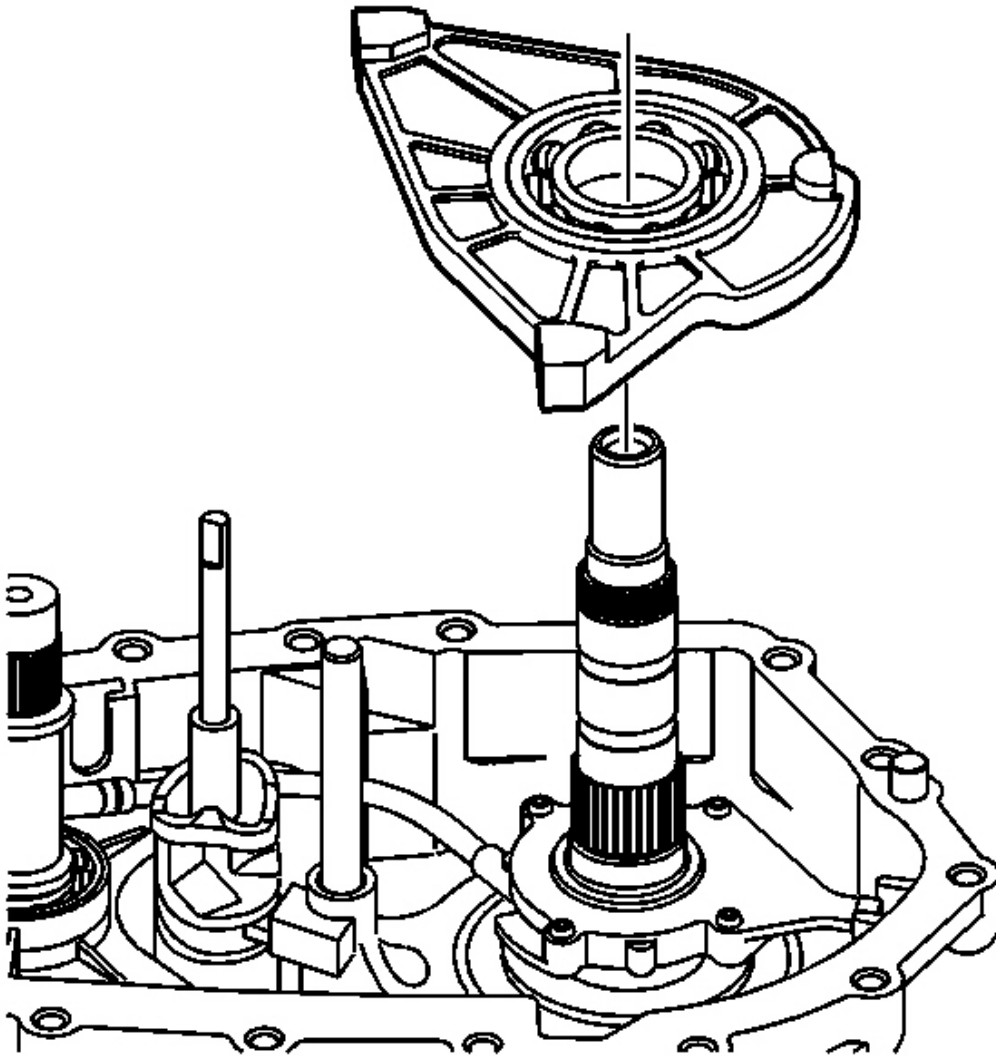

Fig. 114: Identifying Center Bearing Support
Courtesy of GENERAL MOTORS CORP.

27. Install the center bearing support.

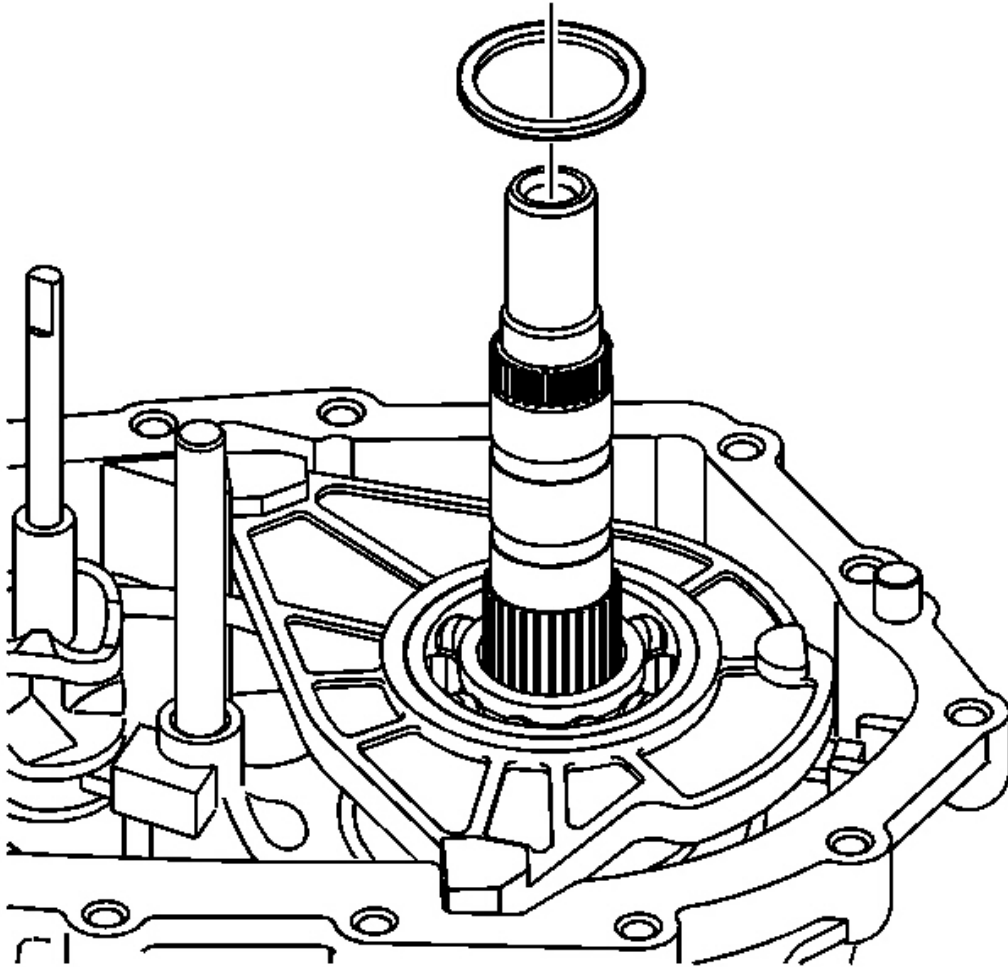

Fig. 115: Identifying Upper Thrust Washer
Courtesy of GENERAL MOTORS CORP.

28. Install the upper center bearing support thrust washer.

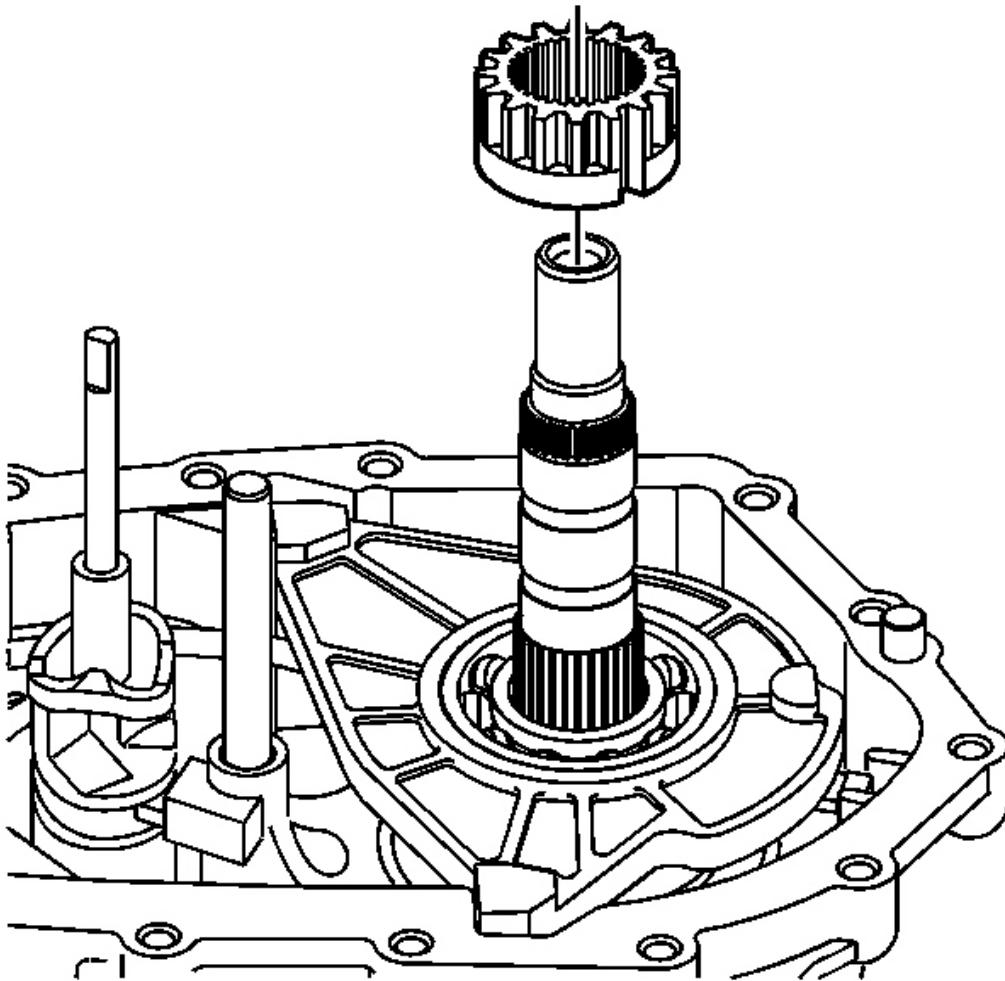

Fig. 116: Identifying Inner Lockup Hub
Courtesy of GENERAL MOTORS CORP.

29. Install the inner lockup hub.

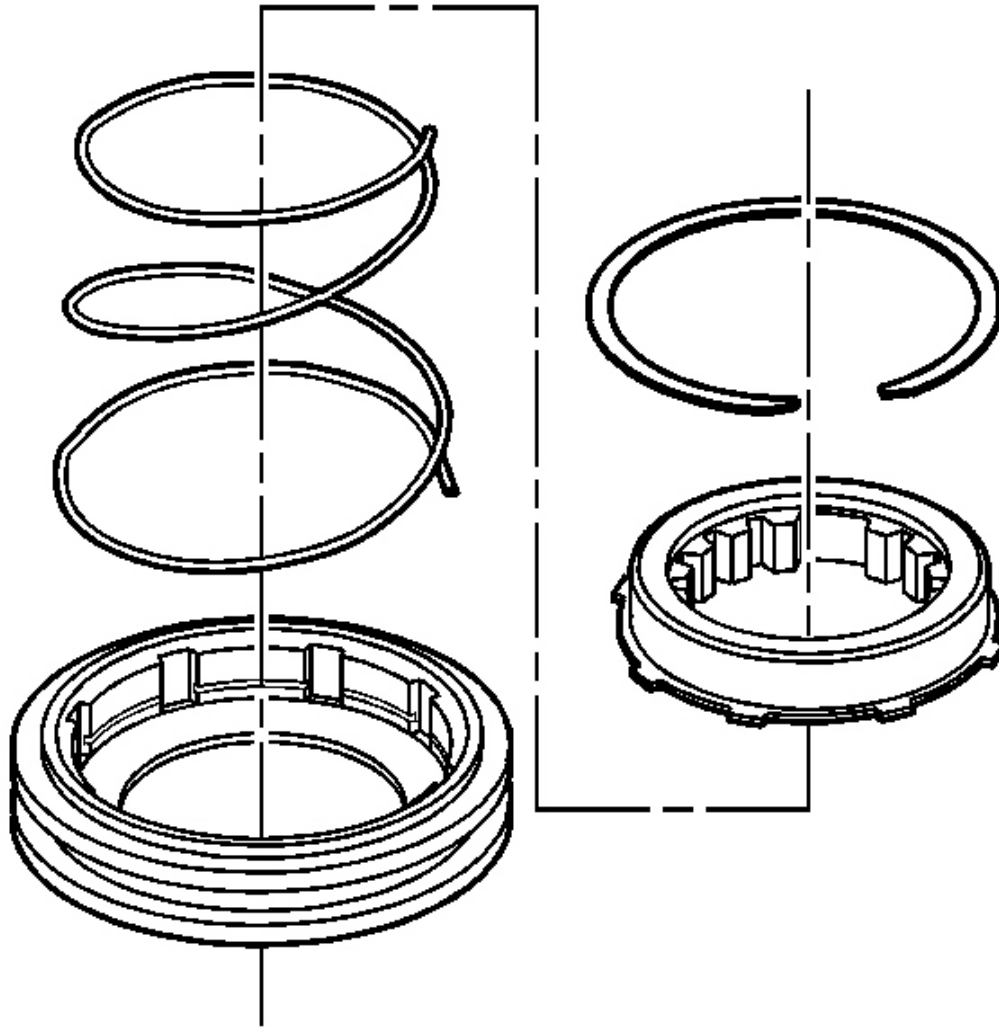

Fig. 117: View Of Lockup Shift Collar Assembly
Courtesy of GENERAL MOTORS CORP.

30. Assemble the lockup mode shift collar assembly, if necessary.
 1. Install the spring in the collar.
 2. Install the hub, with the external tabs toward the spring.
 3. Install the retainer ring in the collar.

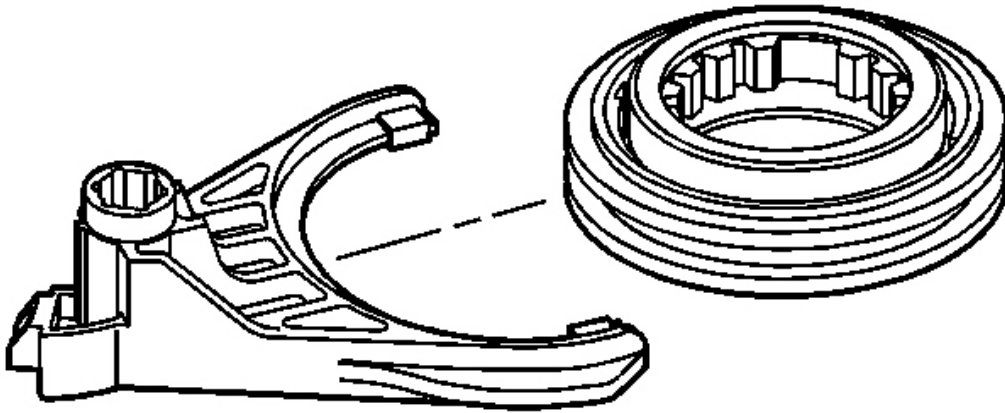

Fig. 118: Identifying Lockup Mode Shift Fork
Courtesy of GENERAL MOTORS CORP.

31. Install the lockup mode shift fork to the lockup mode shift collar assembly.

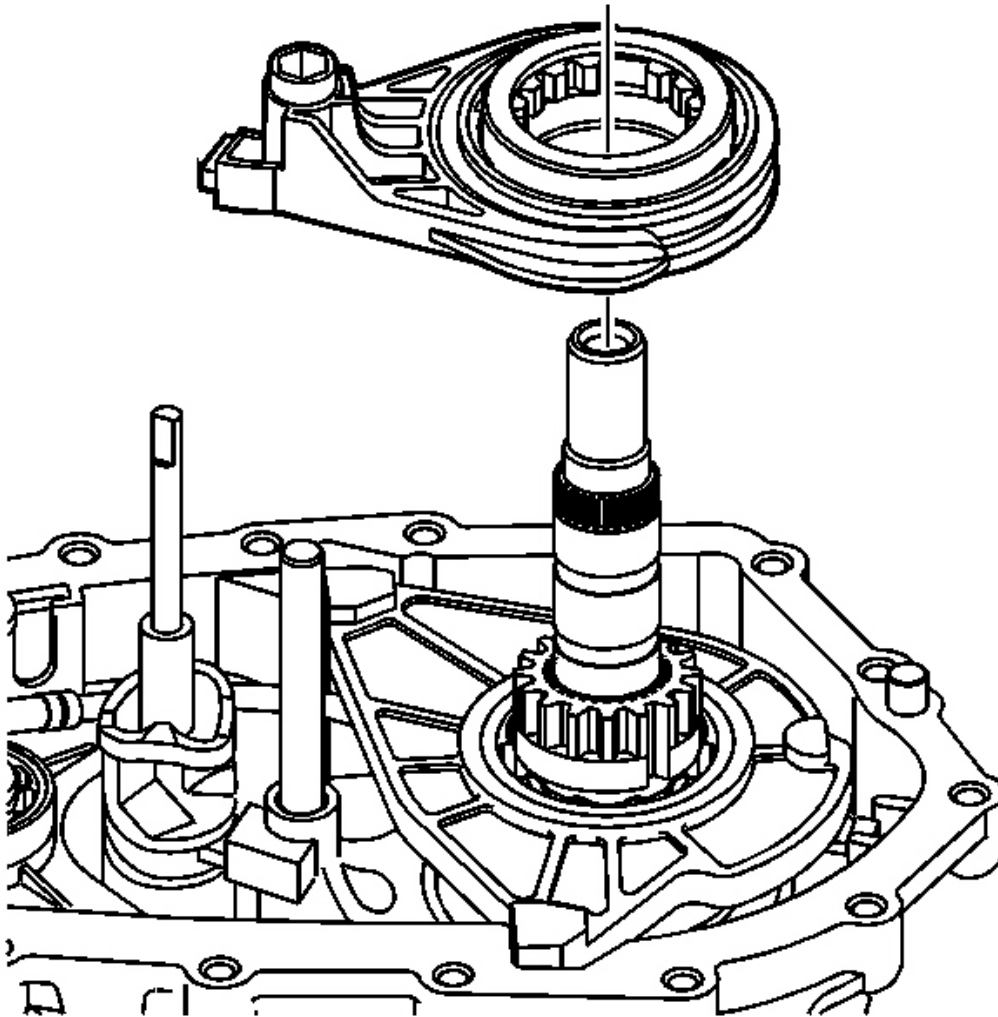

Fig. 119: View Of Lockup Mode Shift Fork & Lockup Shift Collar Assembly
Courtesy of GENERAL MOTORS CORP.

32. Install the lockup mode shift collar assembly and lockup mode shift fork.
 - Slide the shift fork and collar assembly over the shift fork shaft.
 - Turn the mainshaft in order to align the slot on the inner lockup hub with the large tooth area on the hub of the lockup shift collar assembly.

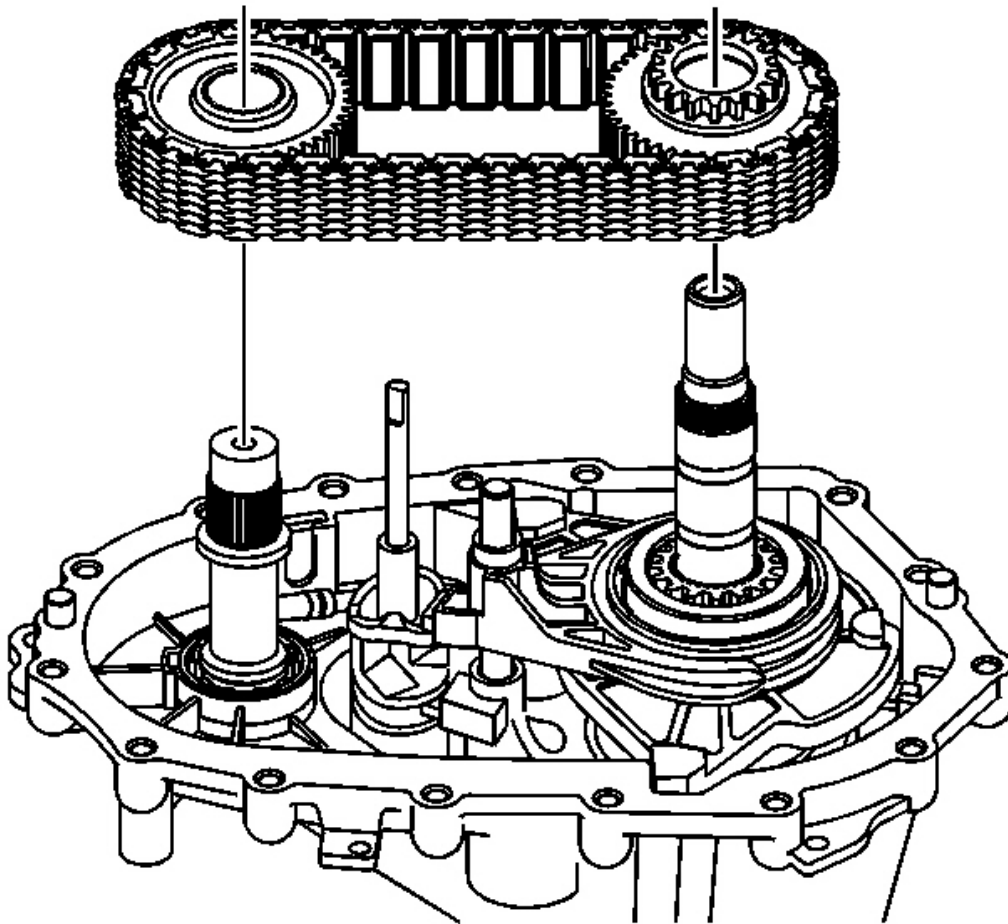

Fig. 120: View Of Chain With Drive Sprocket & Driven Sprocket
Courtesy of GENERAL MOTORS CORP.

IMPORTANT: If using the chain and sprockets again, ensure to align the marks of the drive chain and sprockets.

33. Install the drive chain and sprockets.
 - The blue link on the chain faces up.
 - Align the drive sprocket engagement teeth with the lockup shift assembly hub teeth.

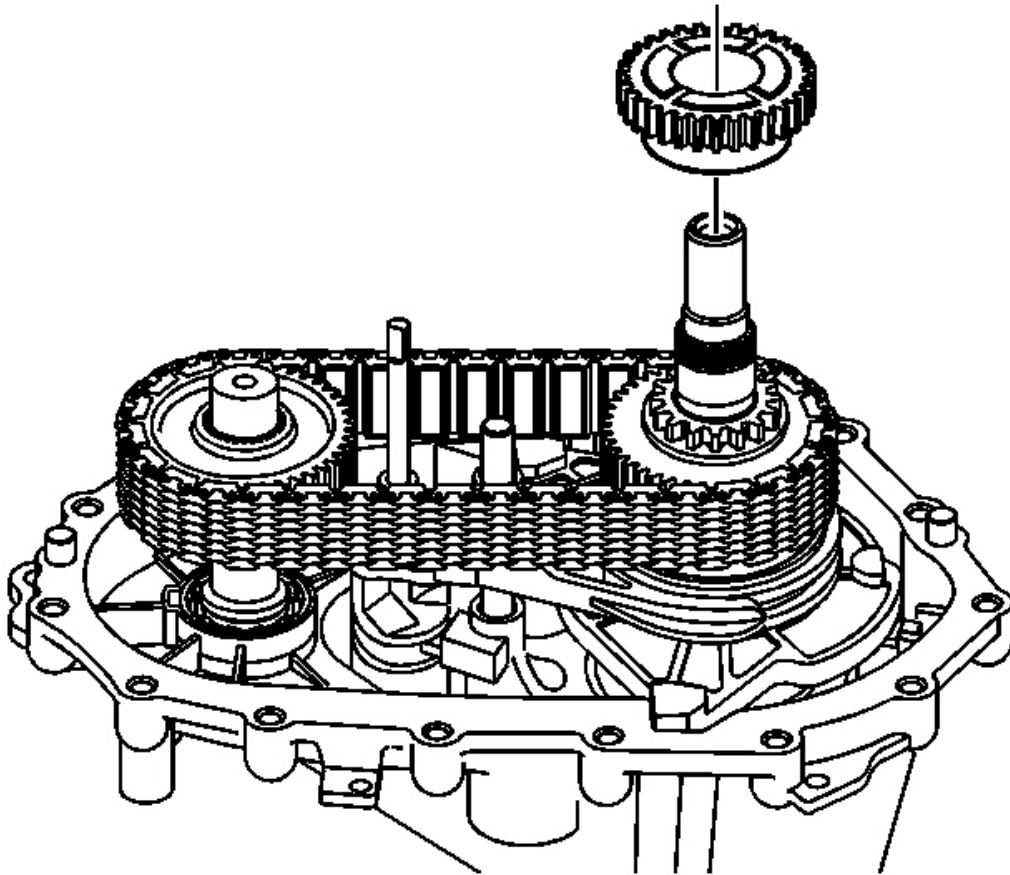

Fig. 121: Identifying Front Output Sun Gear
Courtesy of GENERAL MOTORS CORP.

34. Install the front output sun gear.

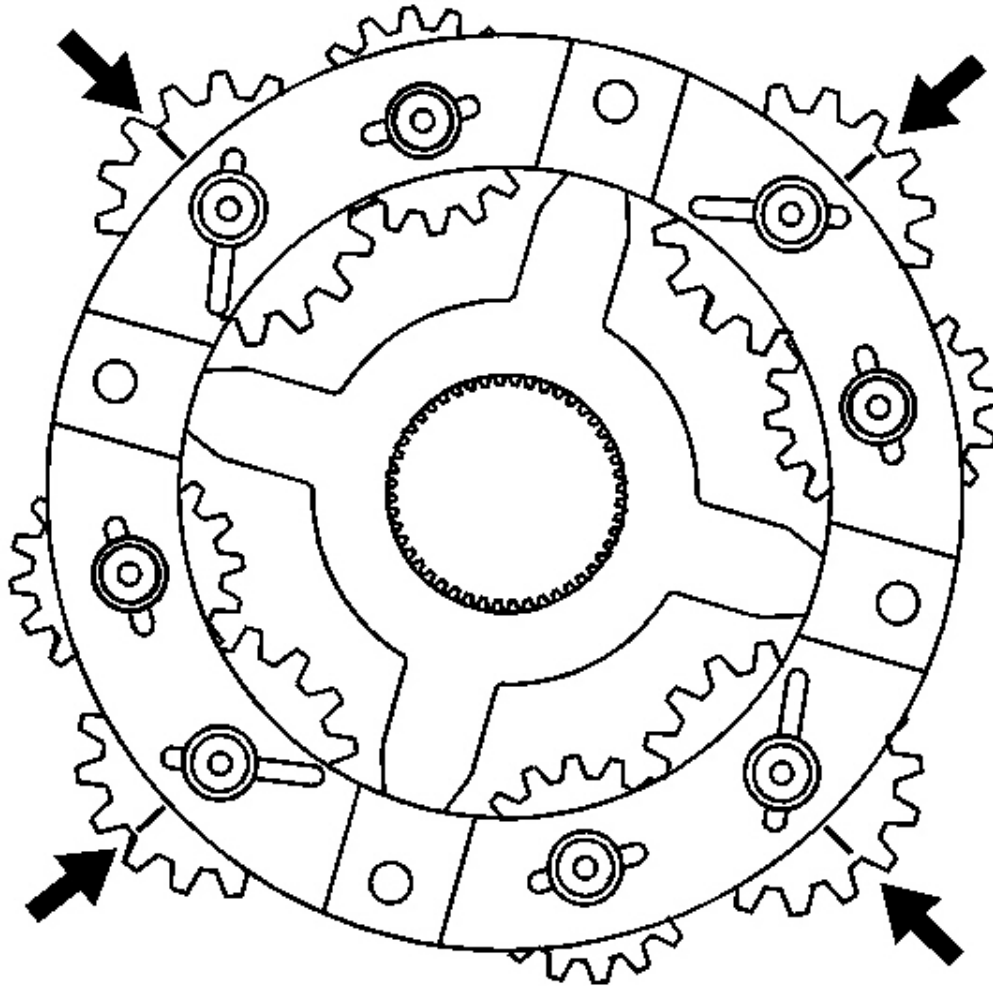

Fig. 122: Aligning Marks On Pinion Gears
Courtesy of GENERAL MOTORS CORP.

IMPORTANT: The planetary differential gears are timed to the sun gears. If the gears are not timed properly, the differential will not rotate without binding.

35. With the rear side of the planetary differential facing up, align the marks on the pinion gears. Position the alignment marks with an area on the planetary differential that can be reference for all gears.

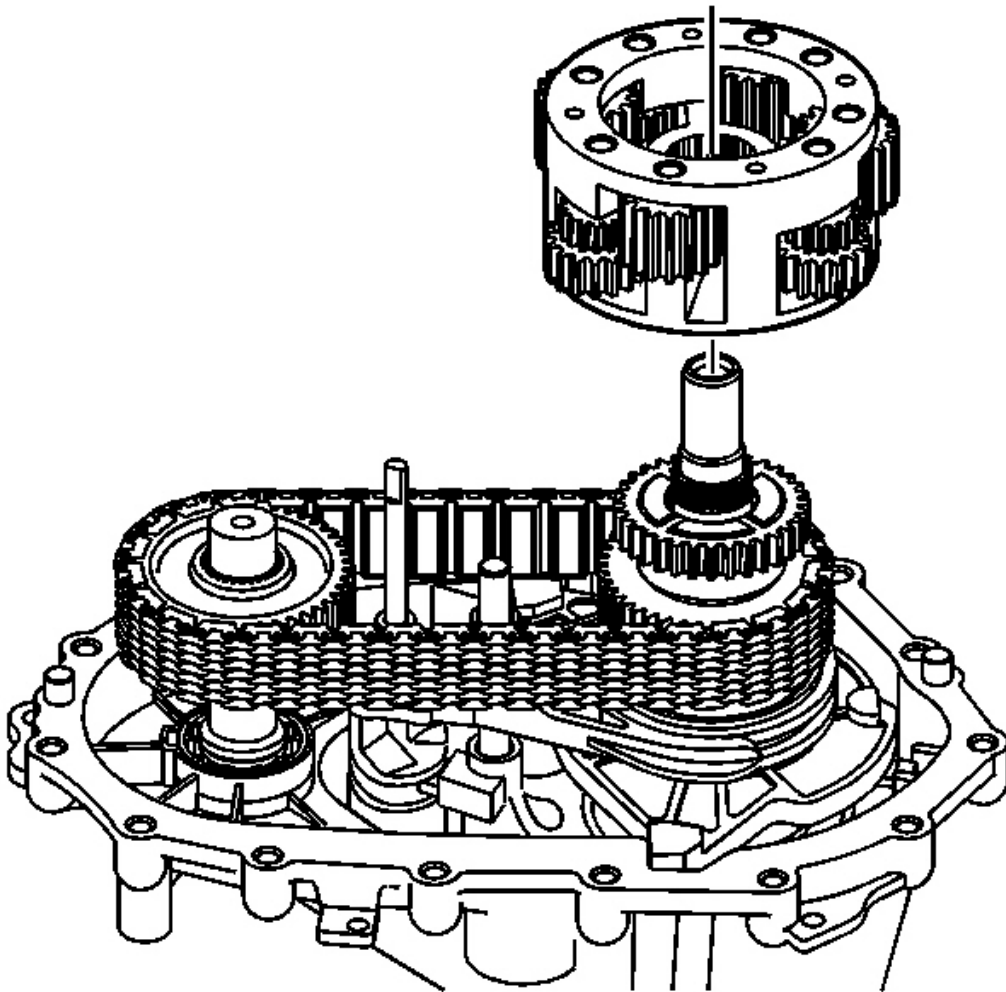

Fig. 123: Identifying Planetary Differential Assembly
Courtesy of GENERAL MOTORS CORP.

36. Install the planetary differential assembly.
- Do not rotate the planetary differential pinion gears when installing.
 - Ensure the alignment marks are in position.
 - The single row pinion gears face rearward or up. The double row pinion gears face forward or down.

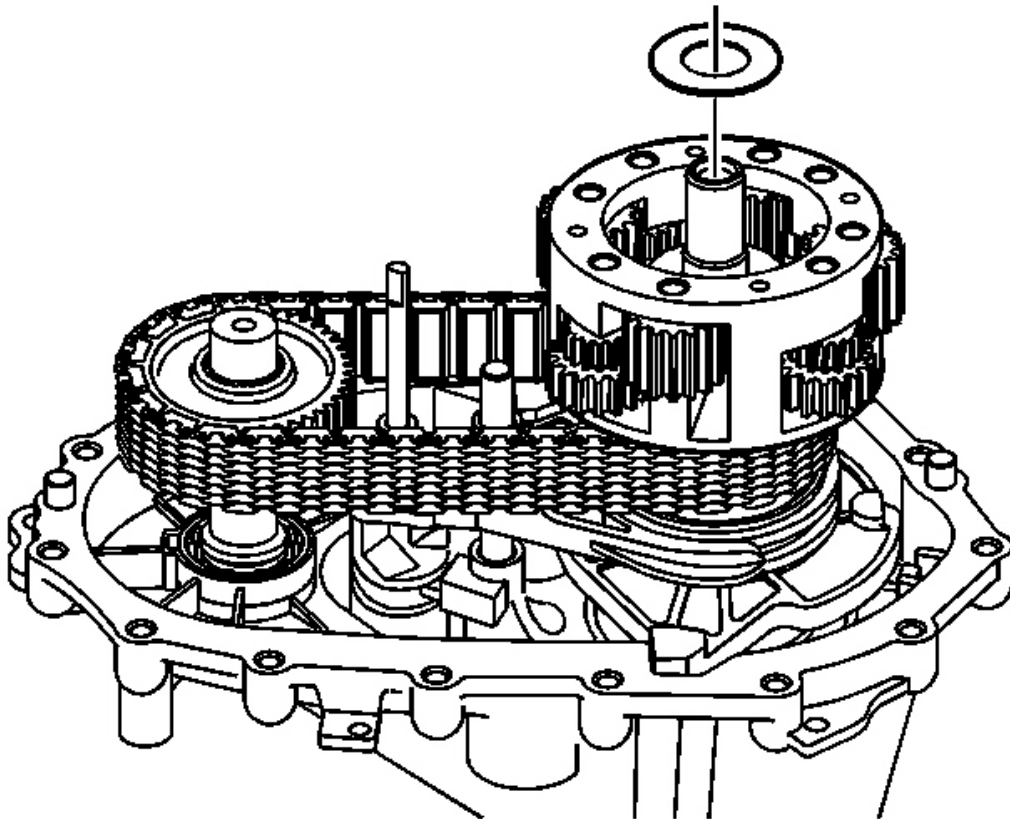

Fig. 124: Removing/Installing Rear Output Shaft Thrust Washer
Courtesy of GENERAL MOTORS CORP.

37. Lubricate the rear output shaft thrust washer with **J 36850** or equivalent.
38. Install the rear output shaft thrust washer.

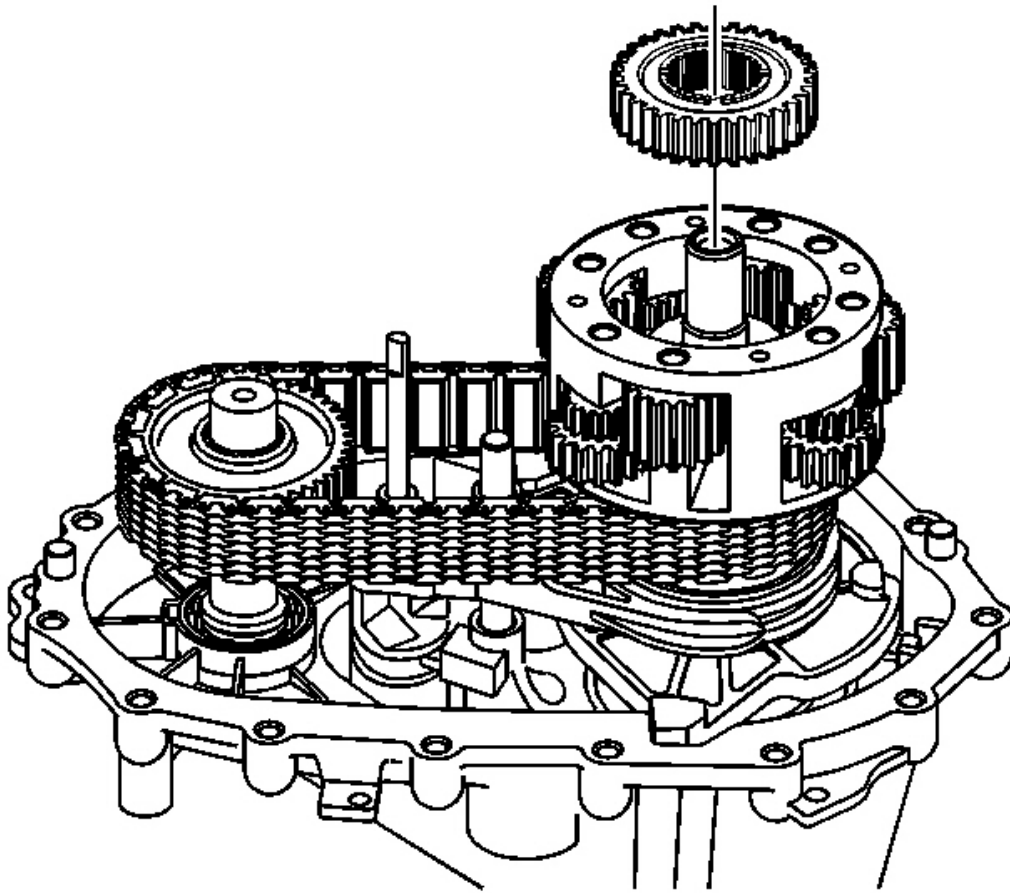

Fig. 125: Identifying Shift Fork Shaft Spring
Courtesy of GENERAL MOTORS CORP.

39. Install the rear output sun gear.
 - The shoulder side of the gear faces up.
 - Do not rotate the differential pinion gears.

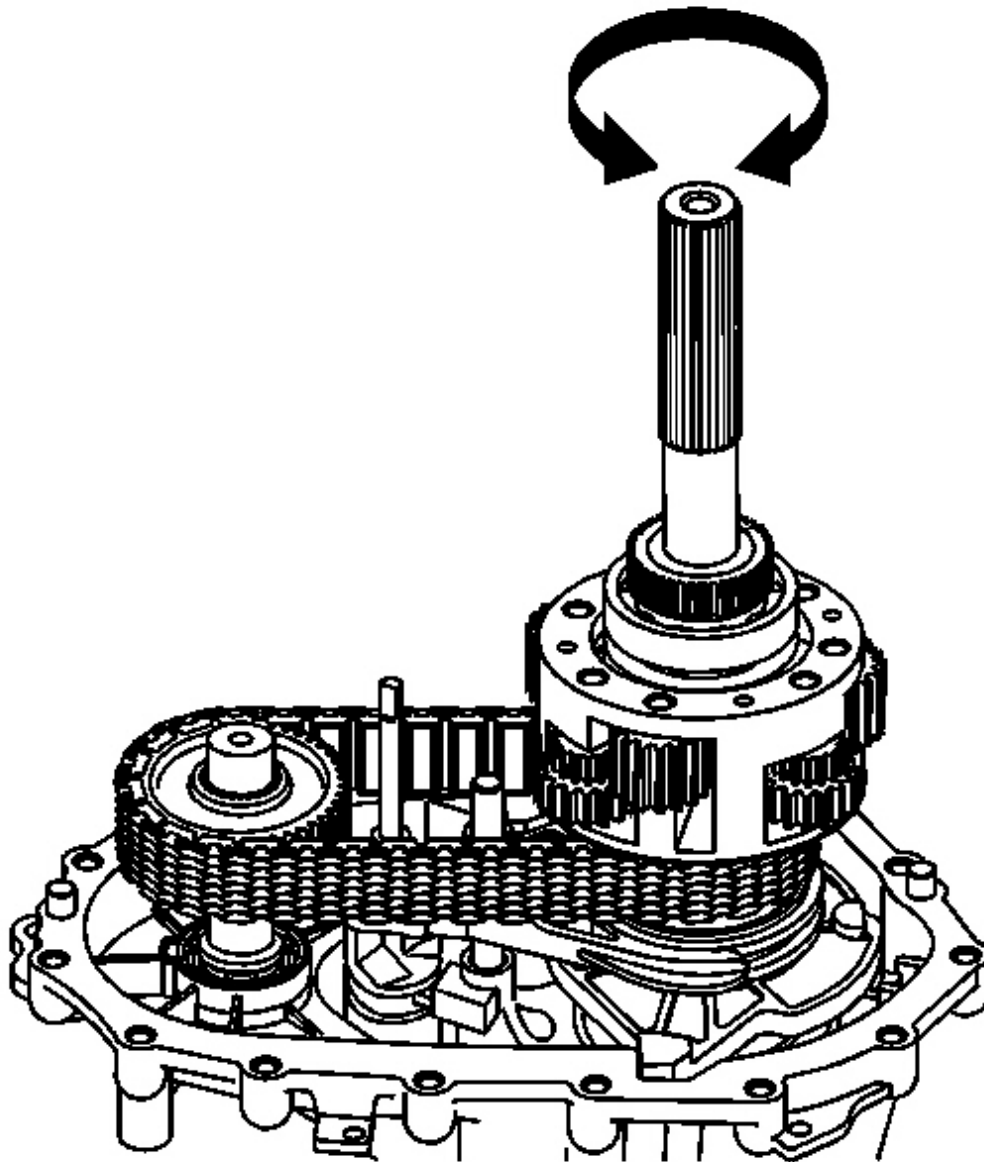

Fig. 126: Rear Output Shaft At Planetary Differential And Rear Output Sun Gear
Courtesy of GENERAL MOTORS CORP.

40. Temporarily install the rear output shaft to the planetary differential and the rear output sun gear.

41. Rotate the rear output shaft 3 or 4 revolutions to rotate the planetary differential pinion gears. If properly aligned, the pinion gears will rotate freely and there will be no binding.
42. Remove the rear output shaft without disturbing the rear sun gear.

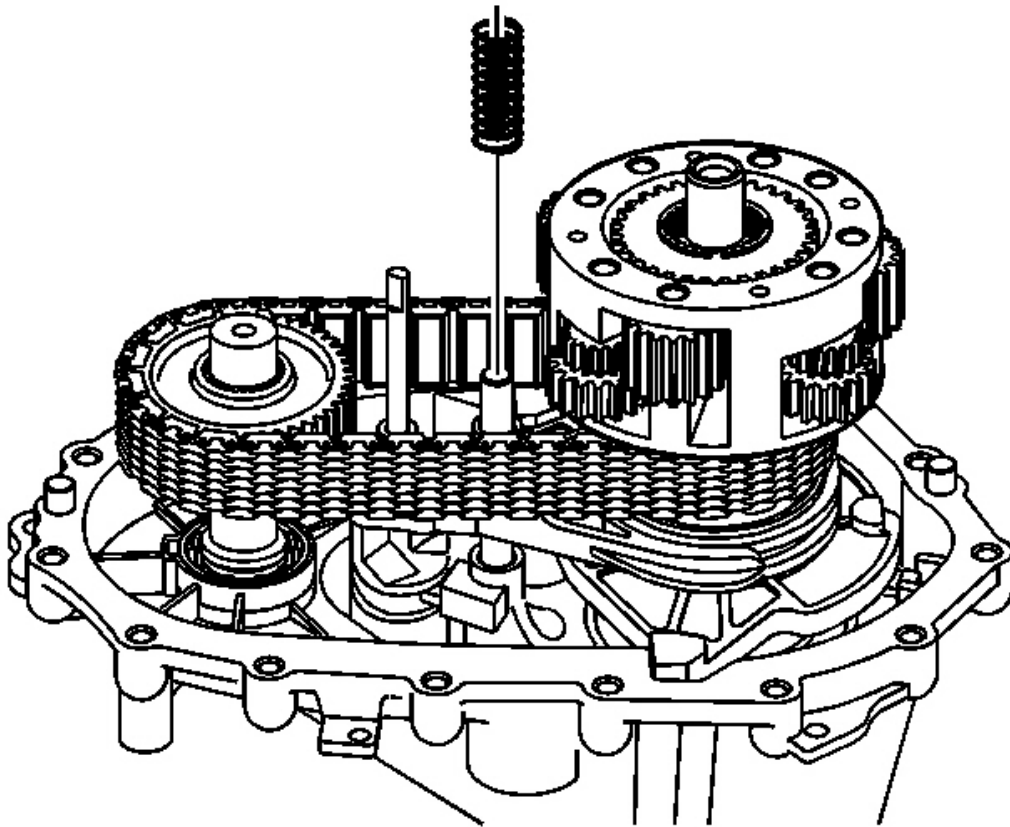

Fig. 127: Identifying Shift Fork Shaft Spring
Courtesy of GENERAL MOTORS CORP.

43. Install the shift fork shaft spring.

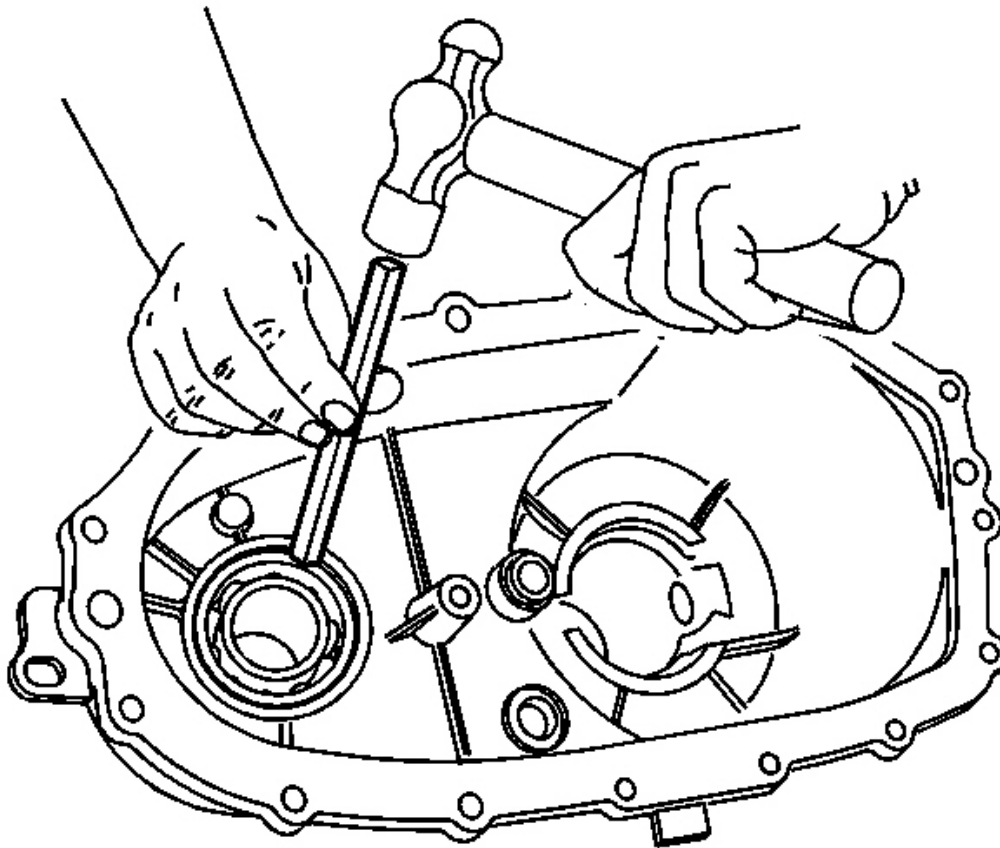

Fig. 128: Installing Front Output Shaft Rear Bearing In Rear Case Half
Courtesy of GENERAL MOTORS CORP.

44. Install the front output shaft rear bearing in the rear case half.
- Use a hammer and a brass drift only on the outer bearing race.
 - Ensure the bearing is kept square to the bore while installing.

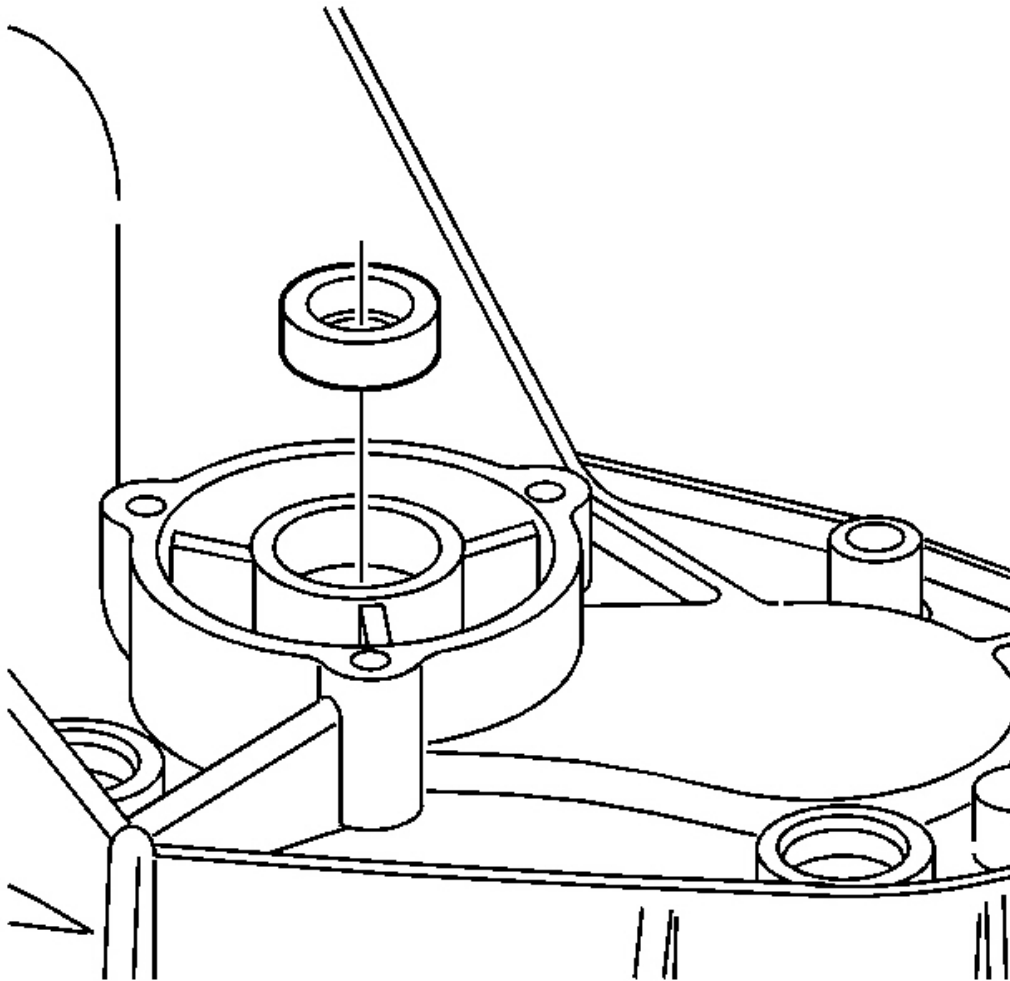

Fig. 129: Locating Shift Shaft Seal
Courtesy of GENERAL MOTORS CORP.

45. Install the shift shaft seal. The seal will install using hand pressure. The spring side or opened side, of the seal faces outward.

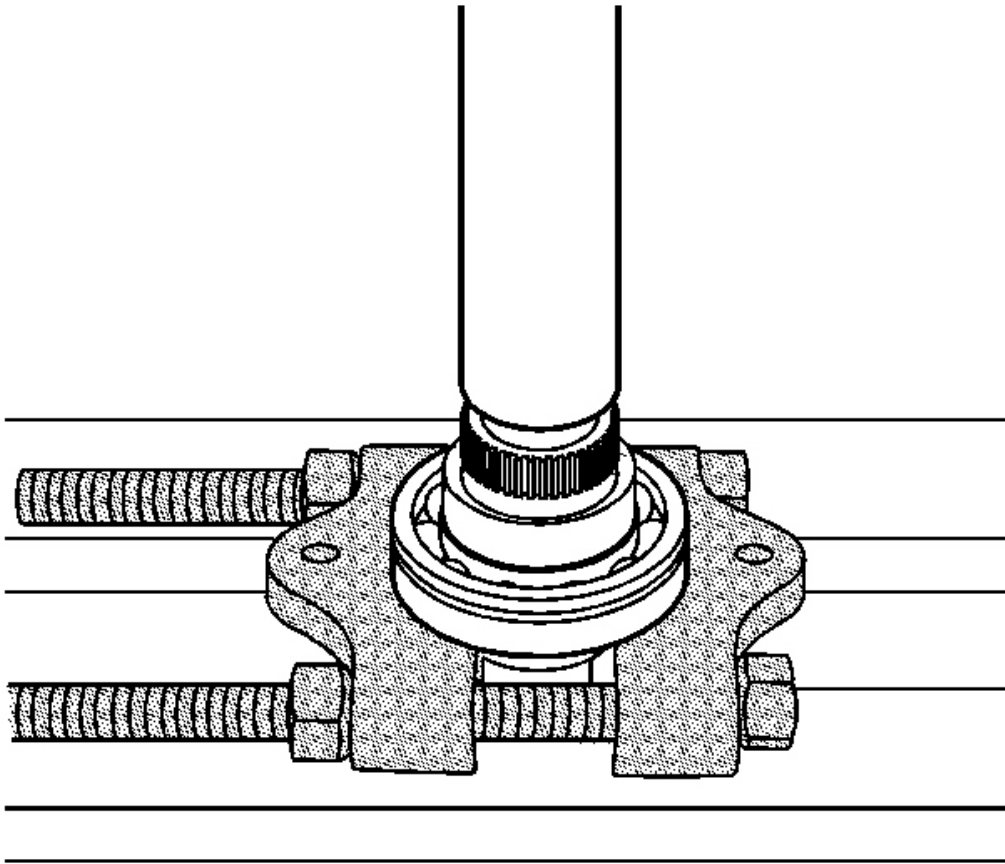

Fig. 130: Using J 22912-01 To Install Rear Output Shaft Bearing
Courtesy of GENERAL MOTORS CORP.

46. Using a hydraulic press and the **J 22912-B** , install the rear output shaft bearing.
- The retaining ring groove on the bearing goes toward the input end or forward.
 - Use a suitable press plate on the end of the rear output shaft.
 - Ensure the bearing is supported on the inner race.

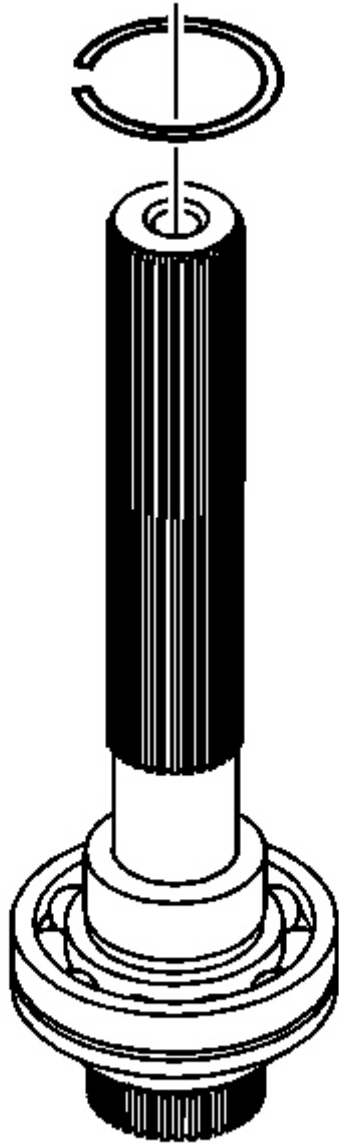

Fig. 131: Identifying Rear Output Shaft Bearing Retaining Ring
Courtesy of GENERAL MOTORS CORP.

47. Install a NEW rear output shaft bearing retaining ring.

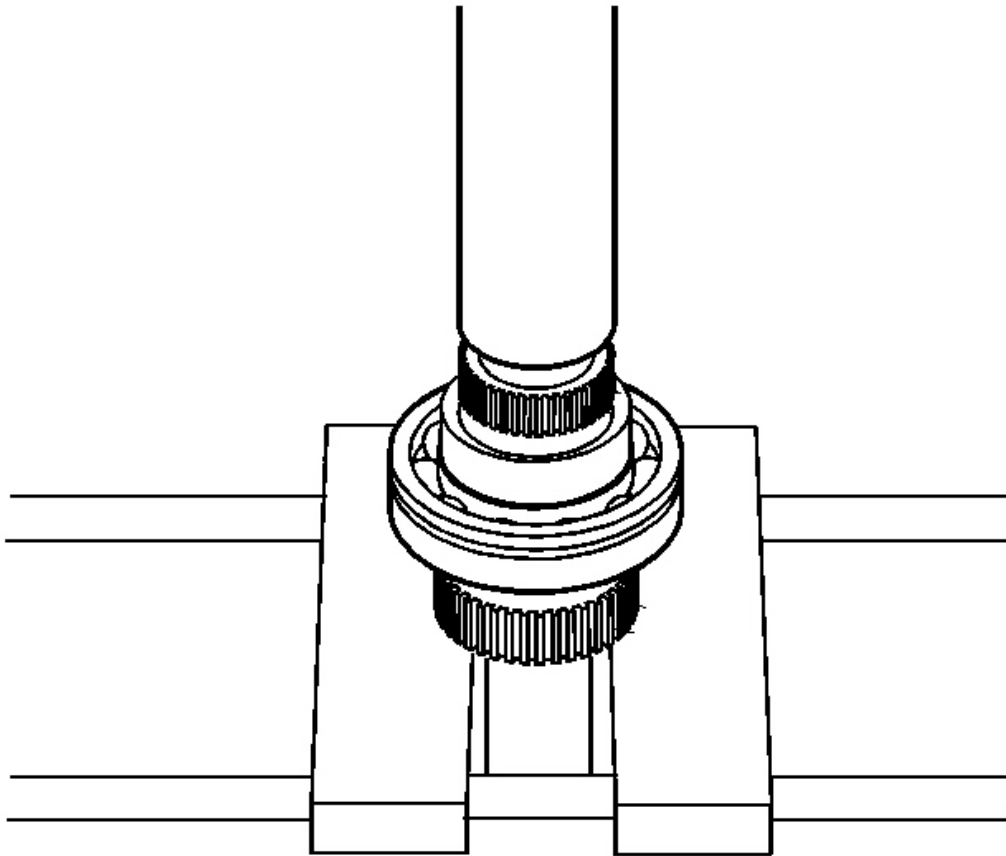

Fig. 132: View Of Speed Reluctor Wheel
Courtesy of GENERAL MOTORS CORP.

48. Using a hydraulic press, install a NEW speed sensor tone wheel.

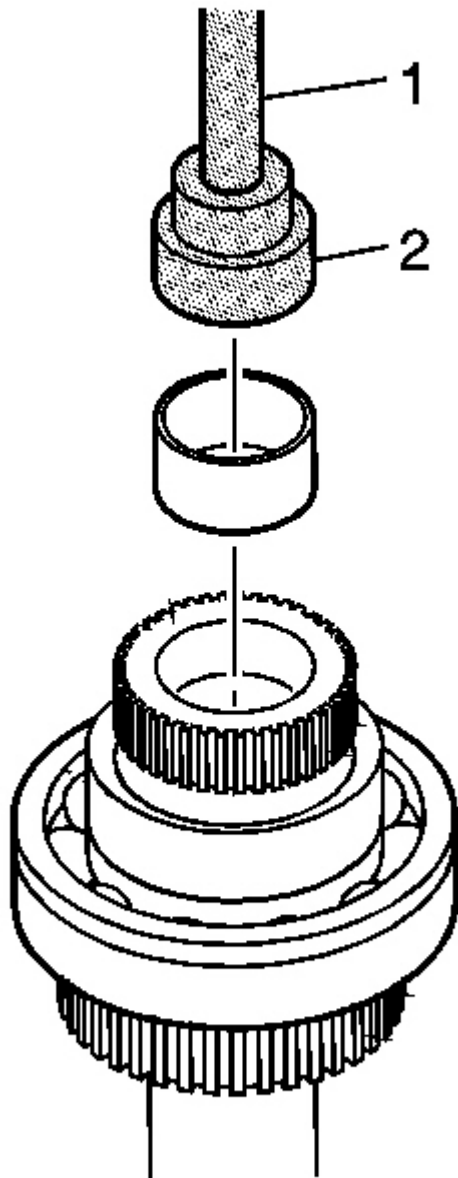

Fig. 133: Pressing Input Shaft Rear Support Bushing In With J 42176 & J 45757
Courtesy of GENERAL MOTORS CORP.

49. Using the **J 42176** (1) and **J 45757** (2), install the mainshaft rear support bushing in the rear output shaft. See **Special Tools**.

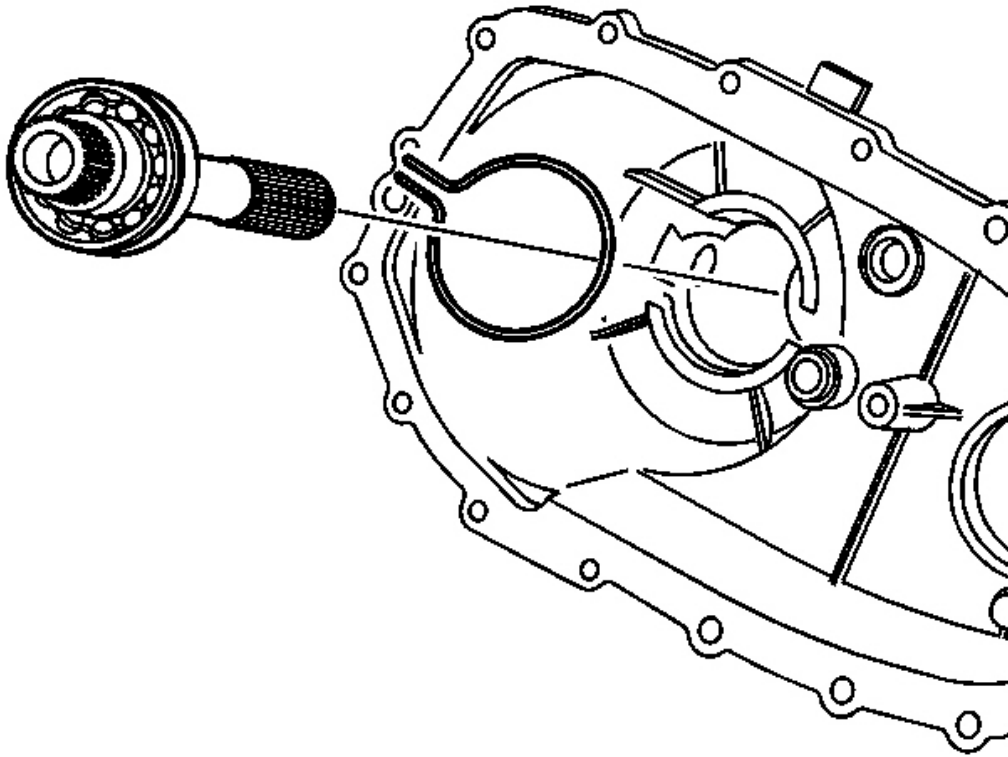

Fig. 134: Identifying Rear Output Shaft
Courtesy of GENERAL MOTORS CORP.

50. Install the rear output shaft in the rear case half.
 1. Spread the rear output shaft bearing outer retaining ring.
 2. Install the rear output shaft bearing outer retaining ring until it is seated in the bearing groove.

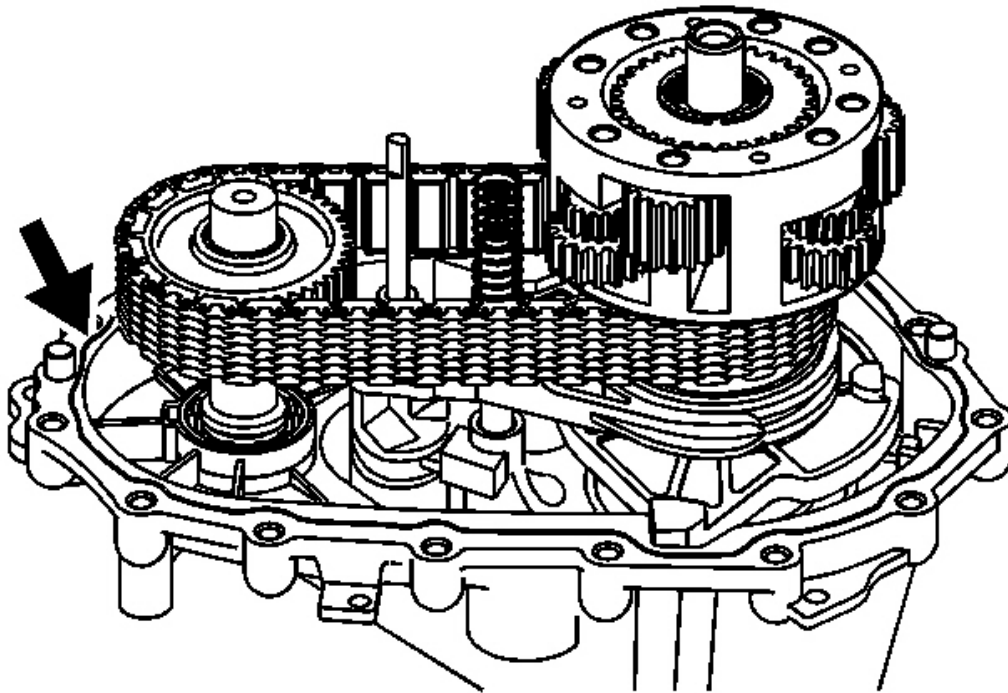

Fig. 135: Applying Proper Amount Of Sealant To Flange
Courtesy of GENERAL MOTORS CORP.

NOTE: Apply the proper amount of sealant to the flange when assembling the transfer case. Excessive amounts of sealant can plug the oil pump screen, resulting in internal component failure.

IMPORTANT:

- Ensure that both the sealing surfaces on the front and rear case halves are free of dirt, oil and cleaning solvent.
- Ensure the locating pins are installed in the case halves.

51. Install the locating pins in the front case and rear case half, if necessary.
52. Apply a 3.175 mm (1/8 in) bead of room temperature vulcanizing (RTV) sealant GM P/N 12345739 (Canadian P/N 10953541) or equivalent, to the mating surfaces of the front case half.

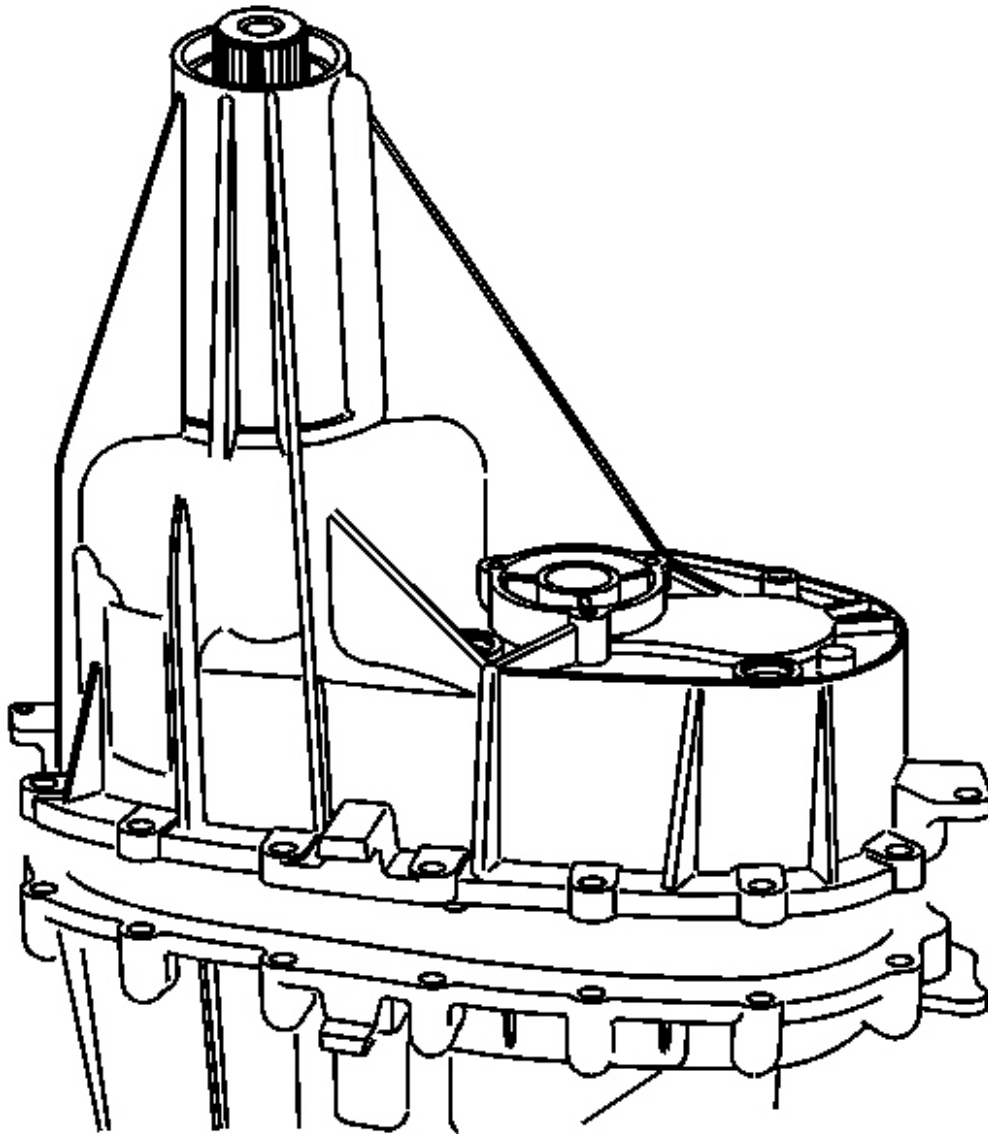

Fig. 136: View Of Rear Case Half & Front Case Half
Courtesy of GENERAL MOTORS CORP.

53. Lower the rear case half into place.

The rear output shaft may require rotating to align the teeth with the planetary differential.

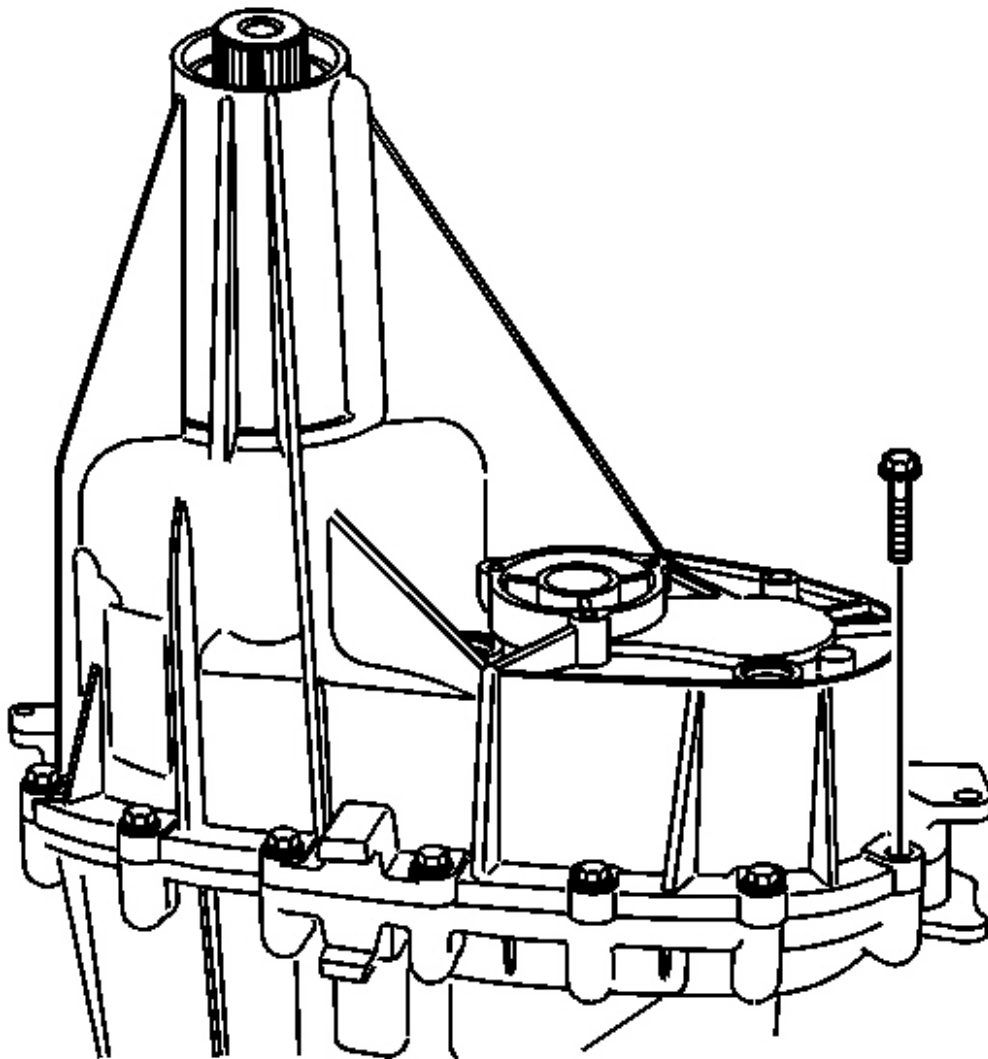

Fig. 137: Identifying Transfer Case Retaining Bolts
Courtesy of GENERAL MOTORS CORP.

NOTE: This component is made of magnesium. Proper assembly is required to prevent damage. Ensure the magnesium transfer case housings are properly insulated from all external steel components or galvanic corrosion will occur. New nylon coated case bolts and aluminum washers must be used. Use only

2007 Hummer H3

2007 TRANSMISSION Transfer Case - BW 4493/4494 - H3

aluminum fill and drain plugs. Use only aluminum brackets under the case bolts. Ensure new seals are installed that have a rubber insulated outside diameter and have no tears or cuts. Extensive damage will occur if there is galvanic corrosion between the magnesium and steel components.

54. Inspect the case bolts nylon coating for cuts or tears.
55. Replace the case bolts if there is any damage to the nylon coating.

IMPORTANT: The case bolts are self-tapping. They must be hand started. Do not use power assisted tools to install the bolts.

56. Install the case bolts with washers and the brackets.

Tighten: Tighten the case bolts to 25 N.m (18 lb ft).

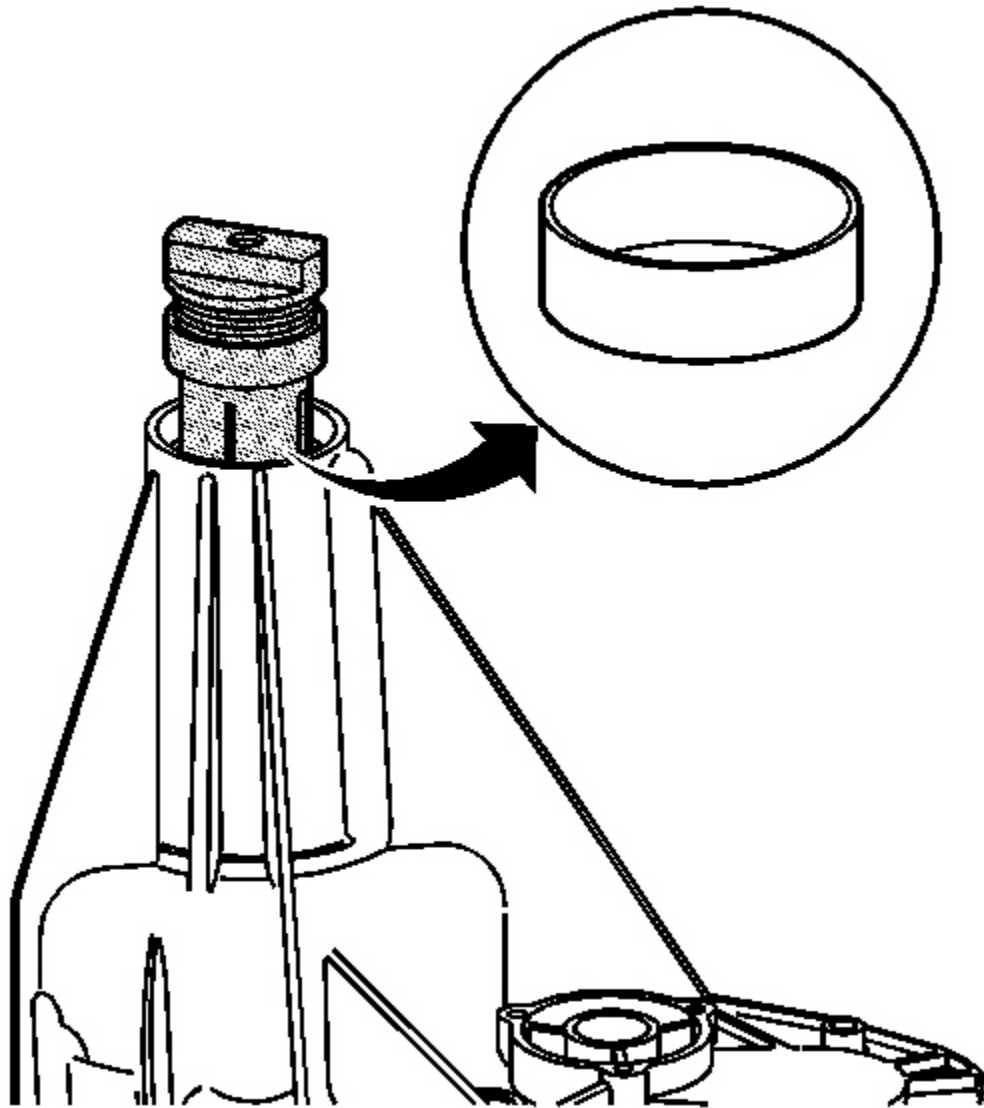

Fig. 138: Installing Output Shaft Bushing
Courtesy of GENERAL MOTORS CORP.

57. Using the **J 45380** , install the output shaft bushing, if removed or new. See **Special Tools**.

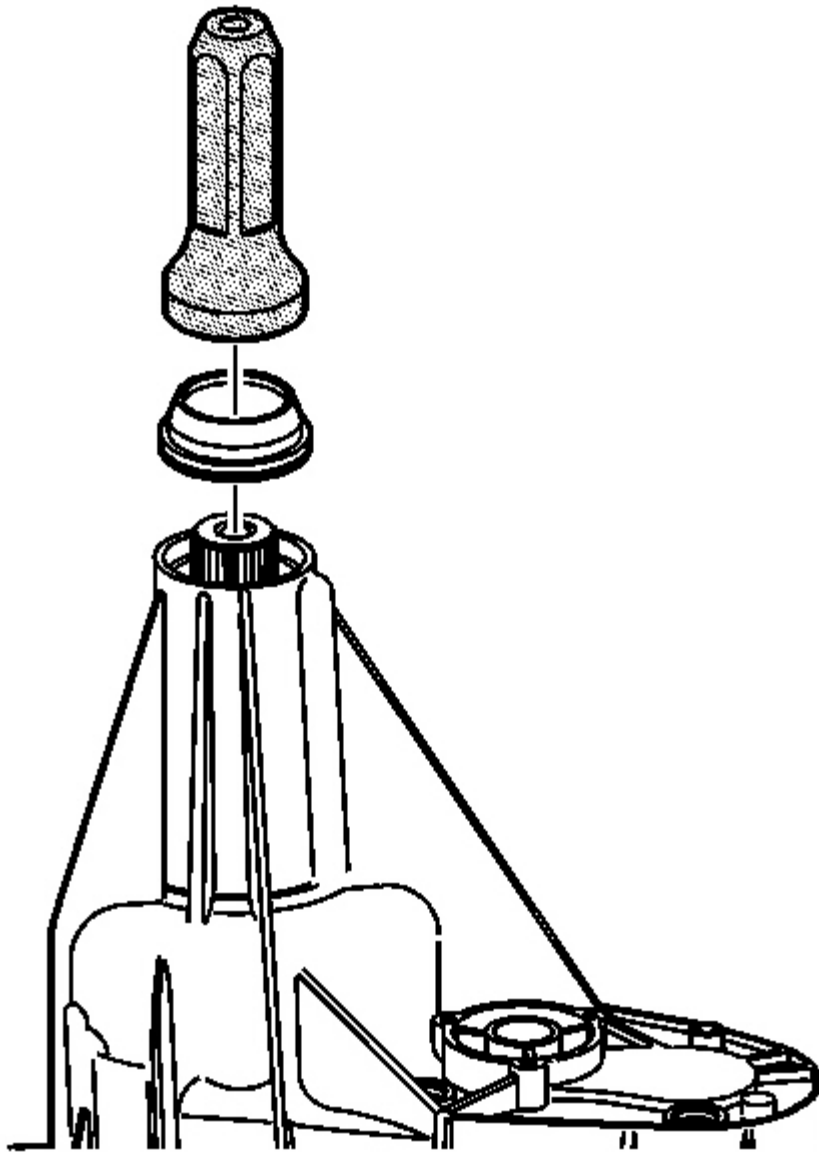

Fig. 139: Installing Rear Output Shaft Seal
Courtesy of GENERAL MOTORS CORP.

58. Using the **J 45756** , install the rear output shaft seal. See **Special Tools**.

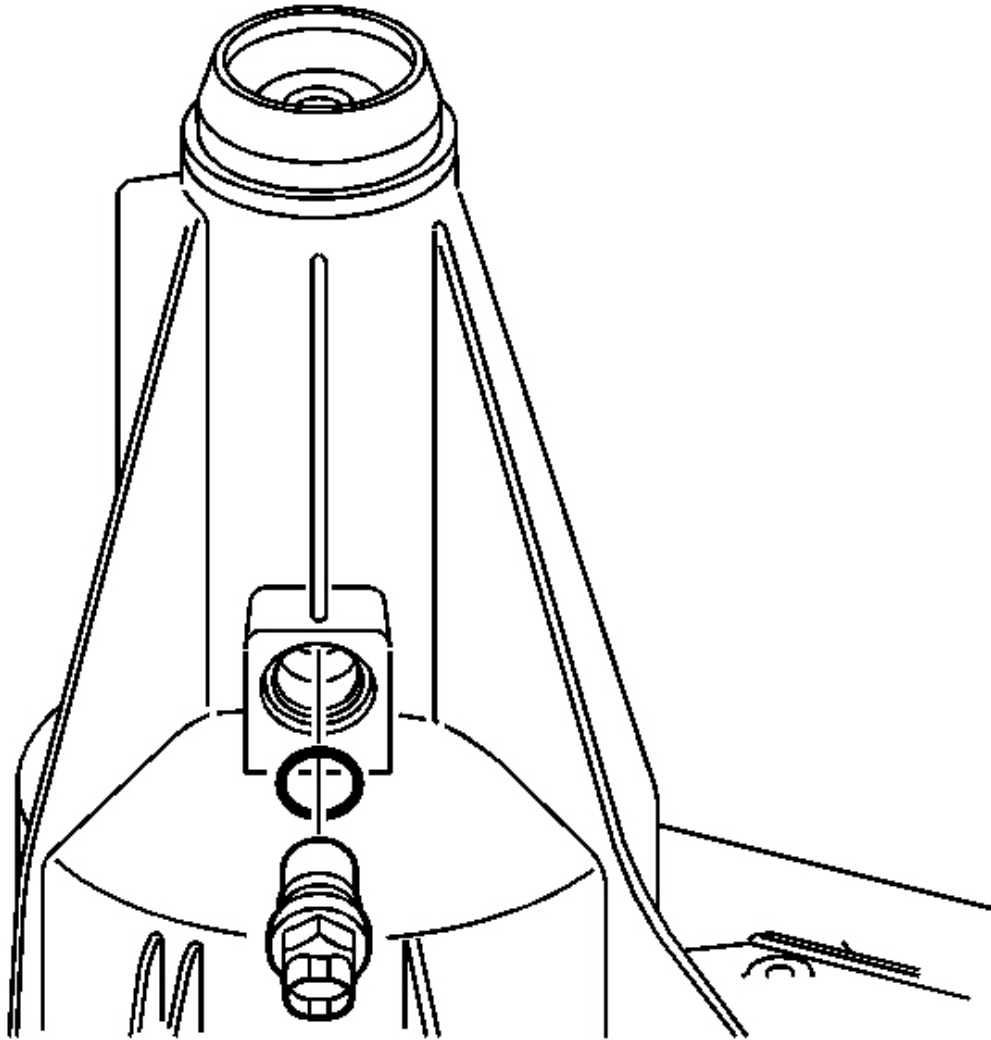

Fig. 140: View Of Vehicle Speed Sensor (VSS) & O-Ring Seal
Courtesy of GENERAL MOTORS CORP.

59. Install the vehicle speed sensor with a new O-ring seal.

Tighten: Tighten the speed sensor to 17 N.m (13 lb ft).

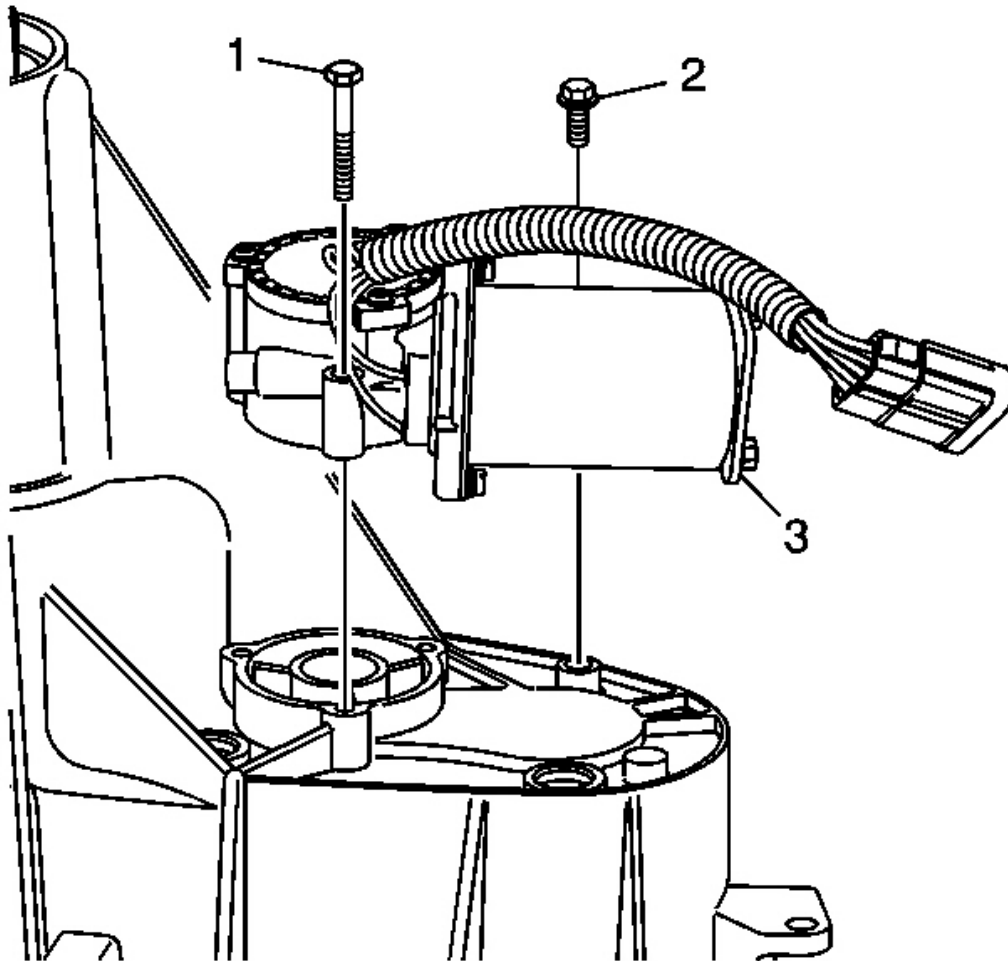

Fig. 141: Locating Encoder Motor, Bracket Bolts And Mounting Bolts
Courtesy of GENERAL MOTORS CORP.

60. Apply a 3.175 mm (1/8 in) bead of RTV sealant GM P/N 12345739 (Canadian P/N 10953541) or equivalent, to the sealing surface of the encoder motor assembly.
61. Install the encoder motor assembly (3). Rotate the shift detent lever to align to the encoder motor.
62. Loosely install the encoder motor mounting bolts (1).
63. Loosely install the encoder motor bracket bolt (2).

Tighten:

- Tighten the encoder motor mounting bolts to 10 N.m (89 lb in).
- Tighten the encoder motor bracket bolt to 10 N.m (89 lb in).

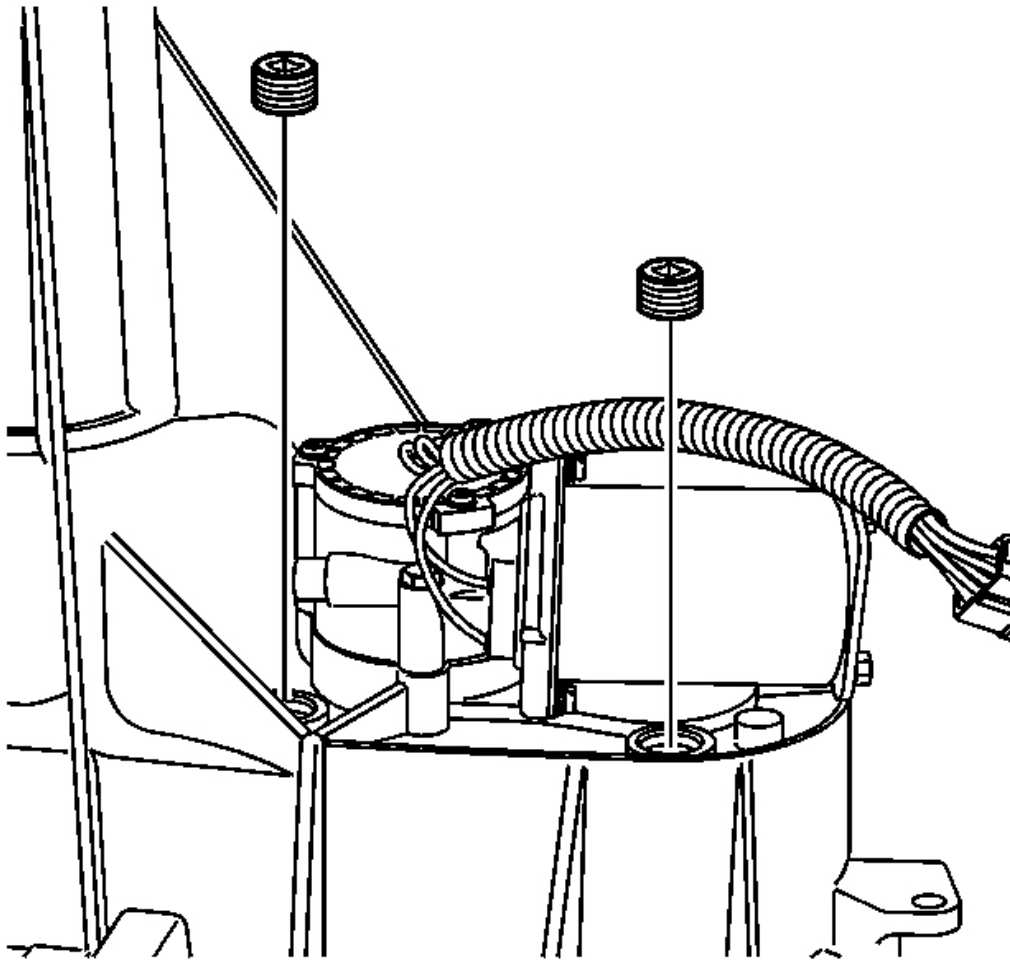

Fig. 142: Locating Drain Plug And The Fill Plug
Courtesy of GENERAL MOTORS CORP.

64. Apply pipe sealant GM P/N 12346004 (Canadian P/N 10953480) to the threads on the drain plug and fill plug.
65. Install the drain plug and the fill plug.

Tighten: Tighten the drain plug and fill plug to 16 N.m (12 lb ft).

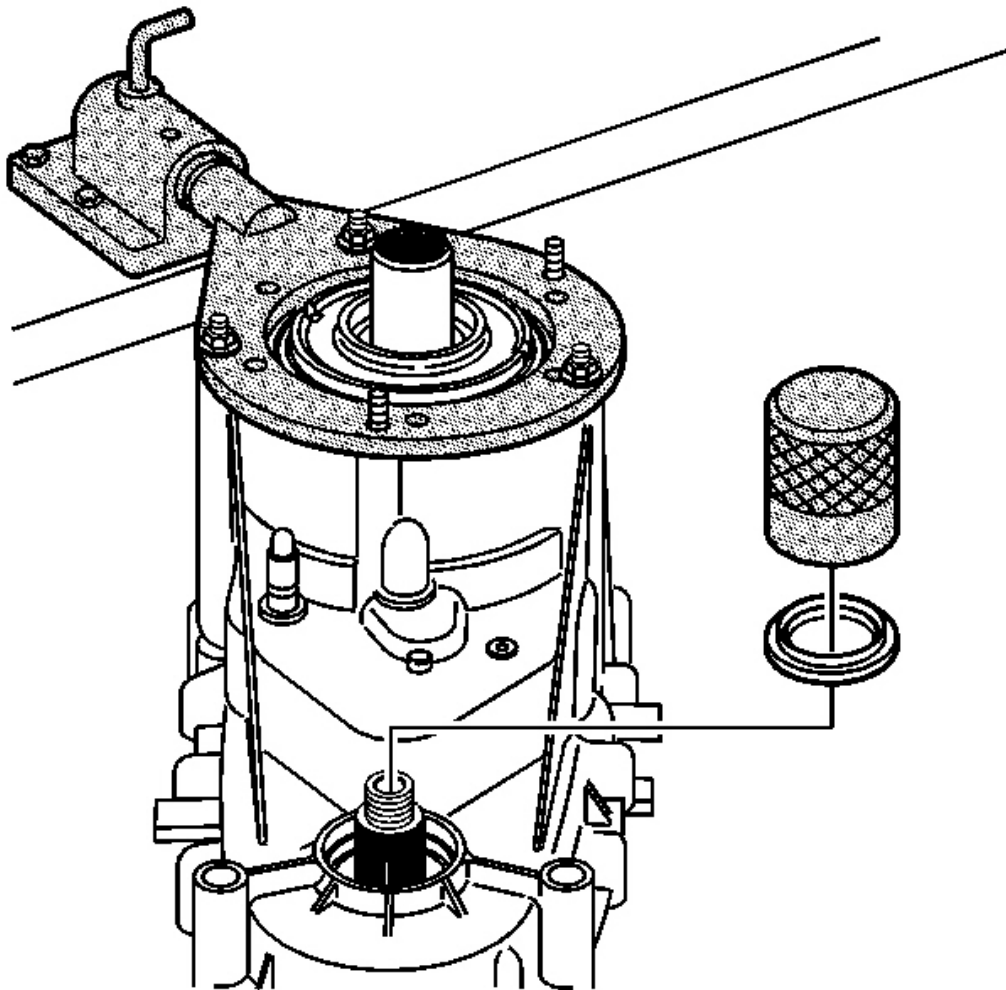

Fig. 143: Installing Front Output Shaft Seal
Courtesy of GENERAL MOTORS CORP.

66. Using the **DT-47847** , install the front output shaft seal. See **Special Tools**.

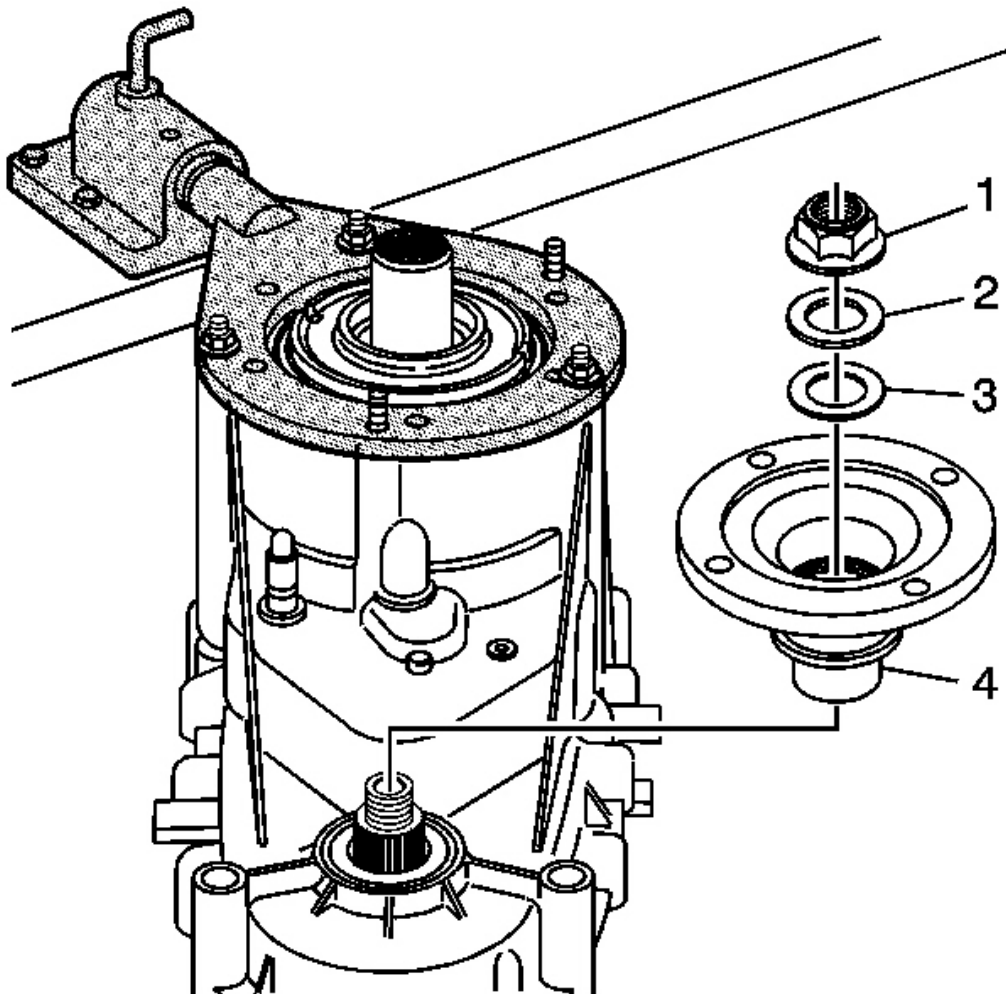

Fig. 144: Front Output Shaft Flange And Components
Courtesy of GENERAL MOTORS CORP.

67. Install the front output shaft flange (4).

IMPORTANT: Ensure the seal is fully seated before installing the washer and nut.

68. Install the front output shaft flange seal (3).

69. Install the front output shaft flange washer (2).

70. Install a NEW front output shaft flange nut (1).

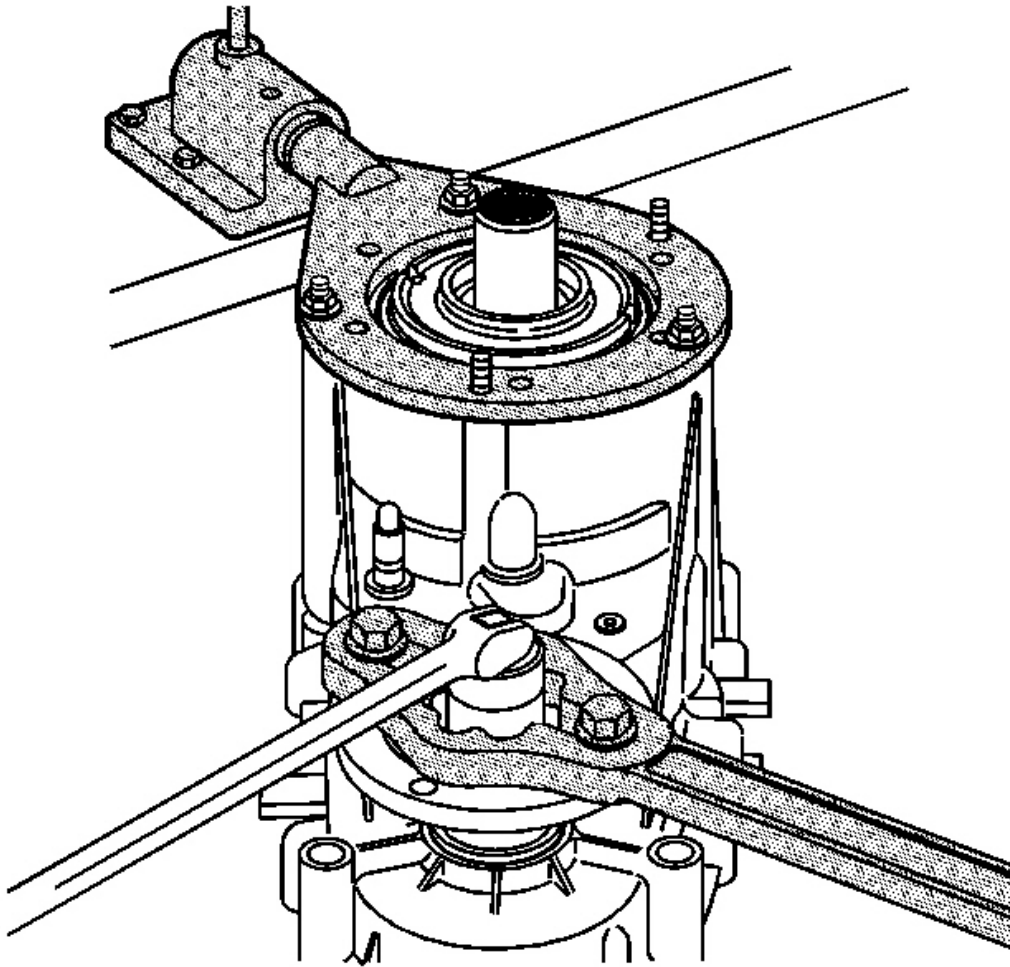

Fig. 145: Tightening Front Output Shaft Flange Nut
Courtesy of GENERAL MOTORS CORP.

71. Install the **J 8614-01** to the front output shaft flange.
72. Hold the **J 8614-01** and tighten the front output shaft flange nut.

Tighten: Tighten the front output shaft flange nut to 319 N.m 235 lb ft.

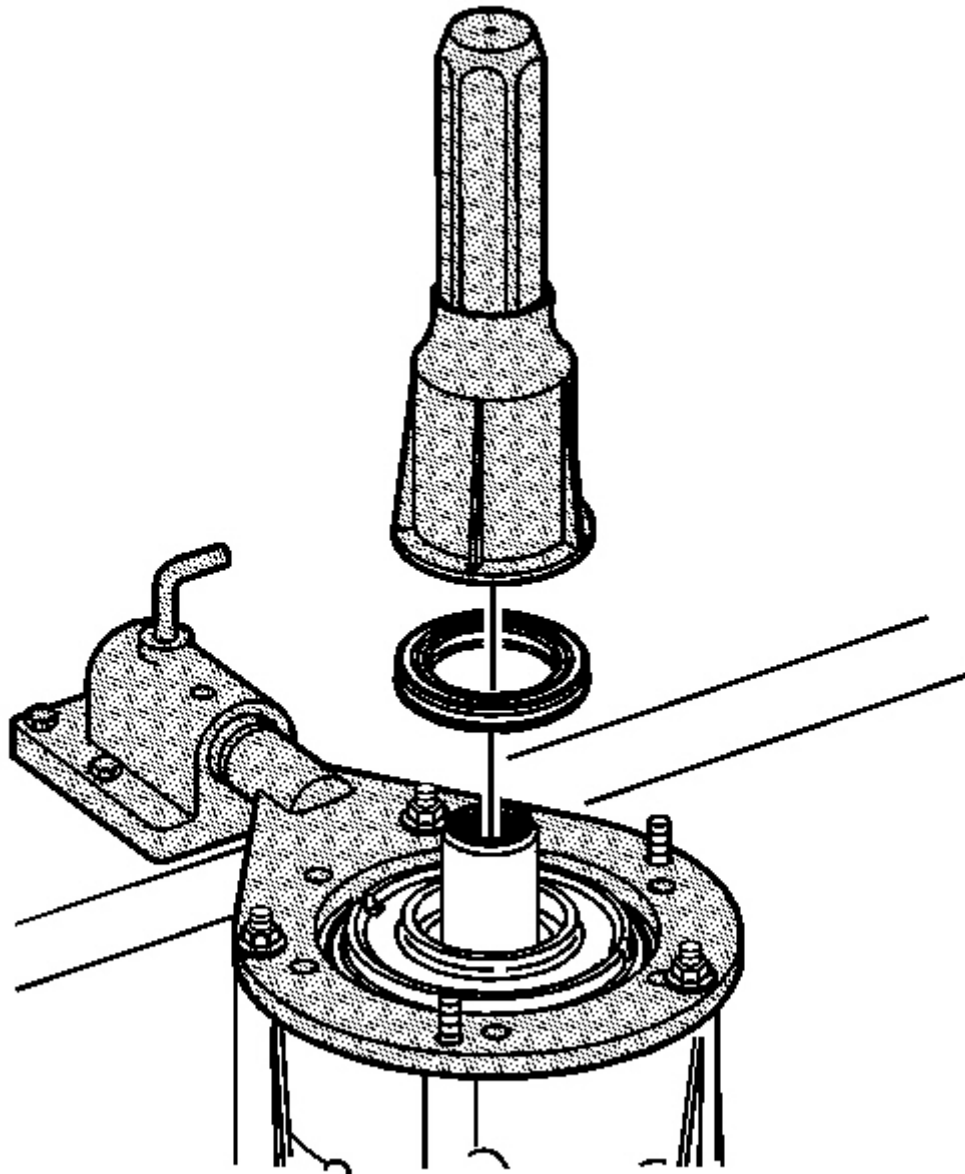

Fig. 146: Installing Input Shaft Seal
Courtesy of GENERAL MOTORS CORP.

73. Using the **J 42738** , install the input shaft seal. See **Special Tools**.
74. Remove the transfer case from the **J 45759** . See **Special Tools**.

DESCRIPTION AND OPERATION

TRANSFER CASE DESCRIPTION AND OPERATION

The Borg Warner (BW) model 4493/4494 NR4 transfer case is a 2-speed, full-time 4WD, transfer case. The transfer case has an external planetary type differential, which has 2 different sets of pinion gears. The planetary differential provides a 40/60 torque split front/rear full-time. This means the front and rear propeller shafts are constantly being driven for maximum traction in all conditions. A high/low planetary carrier assembly provides the high and low ranges, which is a 6-pinion gear, sun gear and annulus gear arrangement, giving a 2.64 low range reduction ratio in the BW 4493 and a 4:1 ratio in the BW 4494.

The BW 4493/4494 case halves are high-pressure die-cast magnesium. Ball bearings support the input shaft, the mainshaft, the front output shaft and the rear output shaft. A needle roller bearing is located inside of the input shaft gear to support the front of the mainshaft. The rear of the mainshaft is supported by a bronze bearing inside the rear output shaft. The transfer case requires DEXRON III ATF Fluid GM P/N 12378470 (Canadian P/N 10952622), which is red in color. An oil pump pumps the fluid through the mainshaft oil gallery to the gears and bearings.

Transfer Case Shift Control Switch

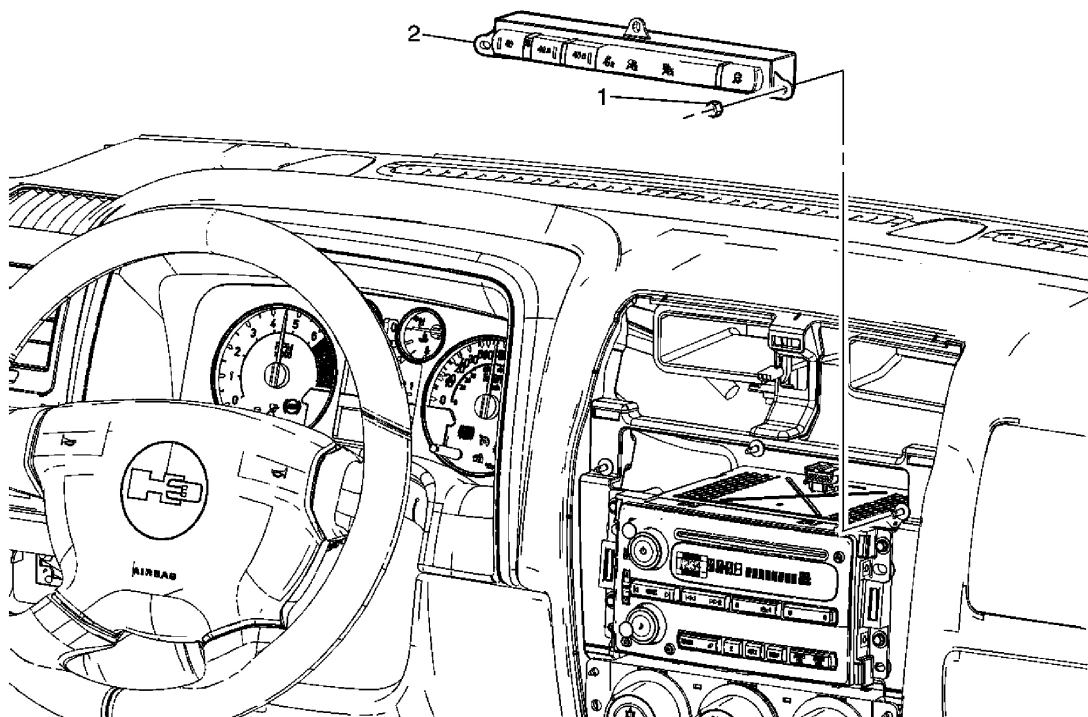

Fig. 147: Transfer Case Shift Control Switch Replacement

Courtesy of GENERAL MOTORS CORP.

The BW 4493/4494 transfer case features a 4-button shift control switch located on the instrument panel. When the vehicle has the ignition key in the RUN position, the transfer case shift control module starts monitoring the transfer case shift control switch to determine if the driver desires a new mode/gear position. At a single press of the transfer case shift control switch, the lamp of the new desired position begins flashing to inform the driver that the transfer case shift control module has received the request for a new mode/gear position. The lamp continues to flash until all shifting criteria have been met and the new mode/gear position has been reached or has been engaged. Once the new mode/gear position is fully active, the switch indicator lamp for the new position remains ON constantly.

During normal driving situations, the transfer case operates in the 4HI mode. When the 4HI mode is selected, the transfer case shift control module sends 12-volts to an electrical motor, which is the transfer case encoder motor. This motor rotates the transfer case shift detent lever shaft which moves the shift forks and range sleeve to obtain different modes/ranges.

The BW 4493/4494 transfer case has the added feature of also providing the driver with 3 manual mode/range positions:

- 4HI - 4-Wheel Drive High Open
- 4HI Lock - 4-Wheel Drive High Locked
- 4LO Lock - 4-Wheel Drive Low Locked

The driver may choose to select any of these mode/range positions while driving the vehicle. However, the transfer case will not allow a shift into or out of 4LO Lock unless the following criteria has been met:

- The engine is running.
- The automatic transmission is in NEUTRAL.
- The vehicle speed is below 5 km/h (3 mph).

This transfer case also has a NEUTRAL position. A shift to the NEUTRAL position allows the vehicle to be towed without the transmission output shaft rotating. Refer to the Owners Manual for instructions for proper towing of the vehicle.

NEUTRAL position may be obtained only if the following criteria have been met:

- The engine is running or the ignition is ON.
- The automatic transmission is in NEUTRAL.

2007 Hummer H3

2007 TRANSMISSION Transfer Case - BW 4493/4494 - H3

- The vehicle speed is below 5 km/h (3 mph).
- The transfer case is in the 4HI mode.

Once these conditions have been met, press and hold both the 4HI and 4LO Lock buttons for 10 seconds. When the system completes the shift to NEUTRAL, the red NEUTRAL indicator illuminates.

The BW 4493/4494 transfer case has 1 other additional feature along with the 3 modes. The electronic rear differential lock can only be used in the 4LO Lock mode with a vehicle speed at or below 32 km/h (20 mph).

4HI Mode Power Flow

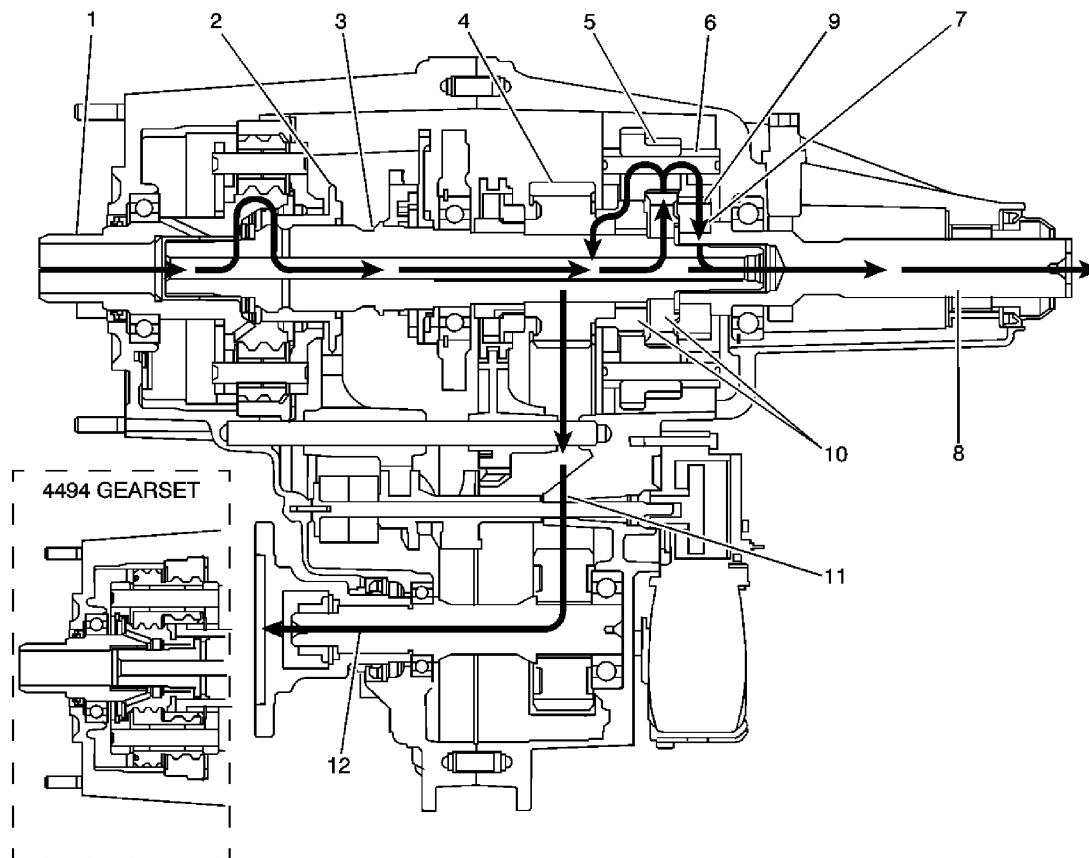

Fig. 148: 4HI Mode Power Flow Diagram
Courtesy of GENERAL MOTORS CORP.

When the BW 4493, shown or the BW 4494, shown in inset, is in 4HI mode, the engine power flows from the transmission to the input shaft (1). The input shaft (1) is connected to the mainshaft

(3) by the high/low range sleeve (2). The high/low range sleeve (2) outer teeth are engaged with the input shaft (1) high-speed teeth. The range collar is slip splined to the mainshaft (3). The mainshaft (3) delivers the power flow to the planetary differential (6), which splits the torque 40 percent through the front differential pinion gears (5) to the front output sun gear (10). The torque to the front axle then goes through the drive sprocket (4), via the chain (11) to the front output shaft (12) and to the front axle. The differential planetary splits the torque 60 percent to differential rear pinion gears (9) and rear output sun gear (7). The rear output sun gear is connected to the rear output shaft (8) and the torque flows to the rear axle. In the 4HI mode, if traction is lost to 1 axle and the tires spin, the traction assist system (TAS) applies braking to the spinning tires and the engine power is delivered to the other tires.

4HI Lock Mode Power Flow

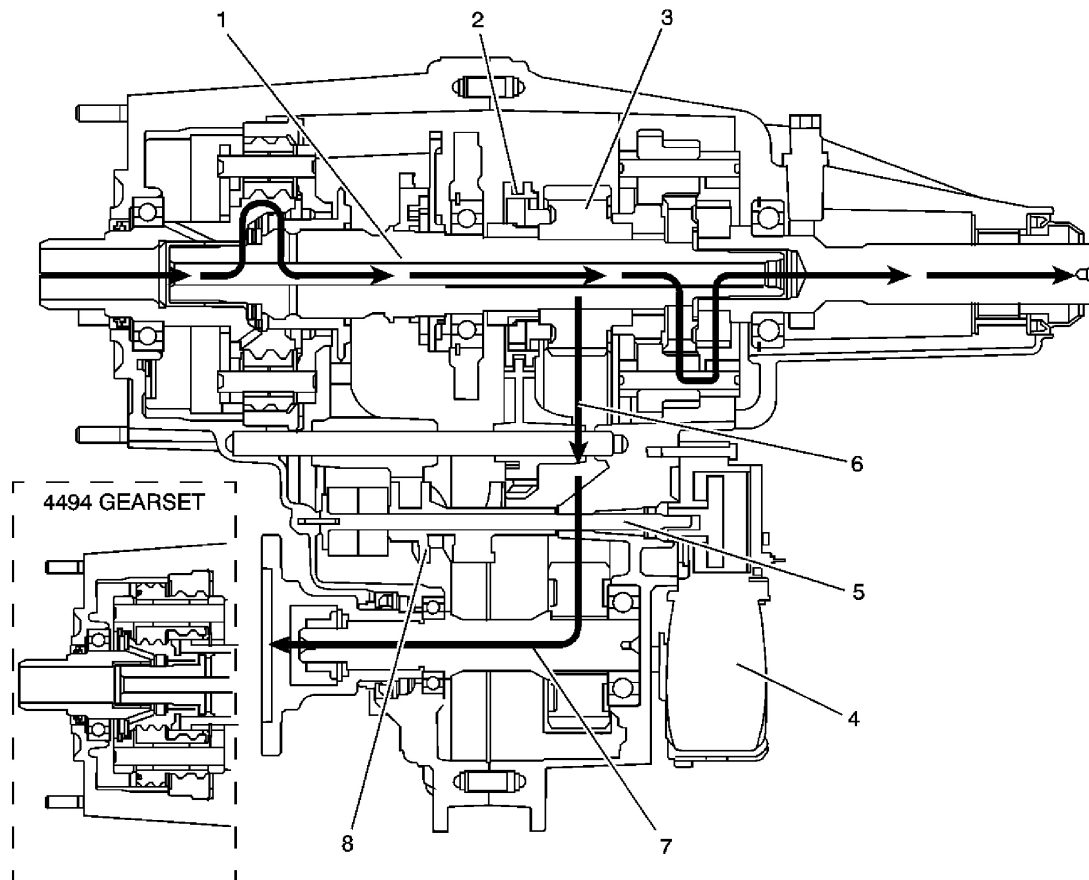

Fig. 149: 4HI Lock Mode Power Flow Diagram
 Courtesy of GENERAL MOTORS CORP.

When the BW 4493, shown or the BW 4494, shown in inset, shifts to the 4HI Lock mode, the encoder motor (4) turns the shift cam shaft (5), to rotate the shift cam (8). The action of the shift

cam (8) moves the lockup mode shift fork rearward along with the lockup shift collar assembly (2). The lockup shift assembly sleeve (2) locks the mainshaft (1) to the drive sprocket (3). Torque is sent by the chain (6) to the front output shaft (7) and to the front axle. The torque distribution in this mode is now determined by vehicle dynamic conditions and weight distribution. The planetary differential is not operating and both the front and rear propeller shafts are being driven at equal RPM, therefore giving a 4 high lock mode. This mode should only be used for extra traction during off road use. Using this mode on dry pavement causes tire scuffing.

4LO Lock Mode Power Flow

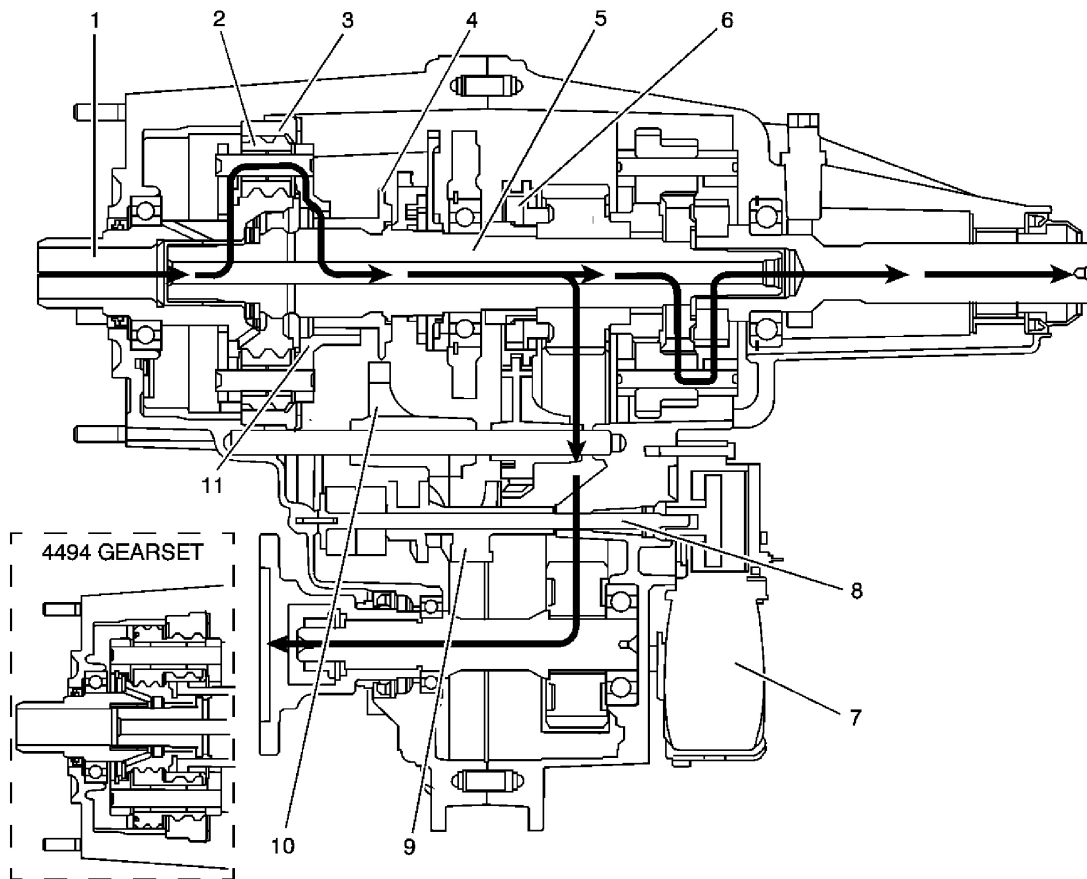

Fig. 150: 4LO Lock Mode Power Flow Diagram
Courtesy of GENERAL MOTORS CORP.

When the BW 4493, shown or the BW 4494, shown in inset, shifts the transfer case to the 4LO Lock mode, it commands the encoder motor (7) to turn the shift cam shaft (8), to rotate the shift cam (9). The range cam profile on the shift cam (9) moves the high/range shift fork (10) and the high/low range sleeve (4) rearward to the 4LO Lock range position. The high/low range sleeve (4) outer teeth disengage from the input shaft (1) high-speed teeth. The high/low range sleeve (4)

2007 Hummer H3

2007 TRANSMISSION Transfer Case - BW 4493/4494 - H3

outer teeth then engage in the high/low planetary carrier teeth (11). The power flow is now from planetary teeth on the input shaft (1) to the planetary gears (2) in the carrier. Rotating the planetary gears, which are engaged in the ring gear (3), rotates the planetary carrier. The planetary carrier delivers the power to the high/low range sleeve (4). The high/low range sleeve (4) then drives the mainshaft (5), providing a 2.64:1 reduction to the speed of the mainshaft (5). When in the 4LO Lock position, the lockup mode shift fork and lockup shift assembly (6) engages in the same way as in the 4HI Lock mode.

NEUTRAL Mode Power Flow

When the BW 4493/4494 shifts to the NEUTRAL position, the high/low range sleeve is centered between the input shaft and the high/low planetary carrier. The high/low range sleeve is not engaged with either the input shaft or the high/low planetary carrier teeth. The planetary differential is in the AWD mode.

Transfer Case Electrical Components

View the list of major electrical components that make up the full-time 4 wheel drive transfer case (FT4WD) system below.

Service 4WD Message

The SERVICE 4WD message is displayed on the driver information center, which is an integral part of the cluster and cannot be serviced separately. This message is used to inform the driver of malfunctions within the FT4WD transfer case system. The SERVICE 4WD message is controlled by the transfer case shift control module via a Class 2 message.

Transfer Case Encoder

The encoder is mounted to the transfer case encoder motor assembly and is replaced only as an assembly. The encoder converts the shift detent lever shaft position, representing a mode/range into electrical signal inputs to the transfer case shift control module. The module detects what position the transfer case is in by monitoring the 4 encoder channels, P, B, A and C. These inputs translate into 4HI, 4HI Lock, 4LO Lock and NEUTRAL or whether the motor is still in transition between gears.

The transfer case encoder channel circuits may be monitored using a scan tool.

Transfer Case Encoder Motor

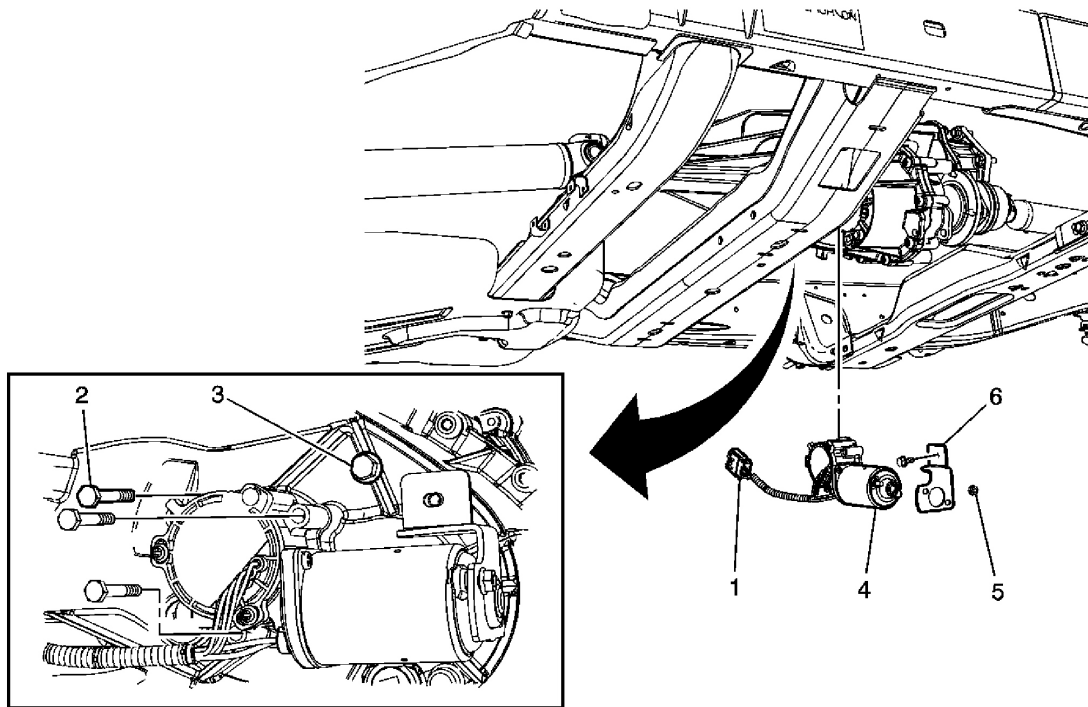

Fig. 151: Transfer Case Motor/Encoder Replacement
Courtesy of GENERAL MOTORS CORP.

The transfer case encoder motor consists of a permanent magnet DC motor and gear reduction assembly. It is located on the left hand side of the transfer case. When activated, it turns the shift detent lever shaft of the transfer case clockwise or counterclockwise, to shift the transfer case by moving the shift forks and collar assemblies inside the transfer case. The encoder motor is controlled through a 12-volt circuit provided by the transfer case shift control module. This circuit consists of a driver on both the Motor Control A and Motor Control B circuits. The encoder motor is bi-directional to allow the motor to shift the transfer case from 4HI or 4HI Lock to NEUTRAL and 4LO Lock positions.

Both the motor control drivers and motor control return drivers can be turned on using a scan tool. You may also monitor Motor Control A and B circuits using a scan tool.

Transfer Case Shift Control Module

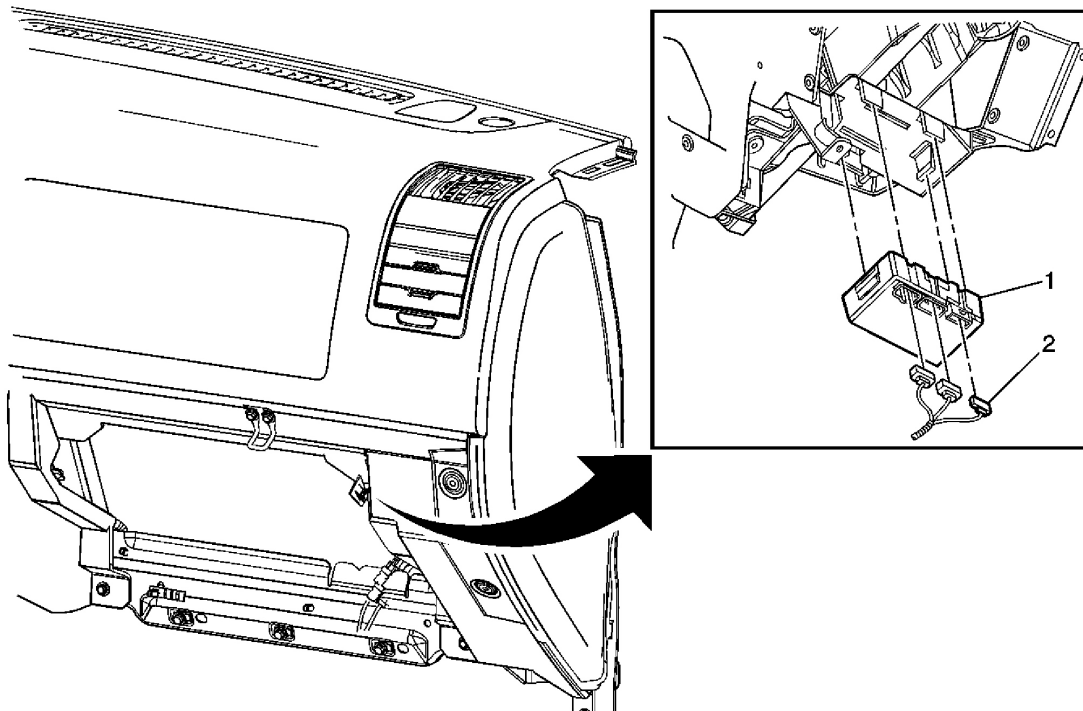

Fig. 152: Transfer Case Shift Control Module
Courtesy of GENERAL MOTORS CORP.

The transfer case shift control module uses the VIN information for calculations that are required for the different calibrations used base on axle ratio, transmission, tire size and engine. The system does not know which calibration to use without this information. This information is provided to the transfer case shift control module via Class 2 data bus from the powertrain control module (PCM). The transfer case shift control module monitors vehicle speed via the Class 2 data bus from the PCM as well as controlling the operation of the transfer case encoder motor assembly.

SPECIAL TOOLS AND EQUIPMENT

SPECIAL TOOLS

Special Tools

Illustration	Tool Number/Description
	DT-47847

2007 Hummer H3

2007 TRANSMISSION Transfer Case - BW 4493/4494 - H3

Front Output Shaft Seal Installer

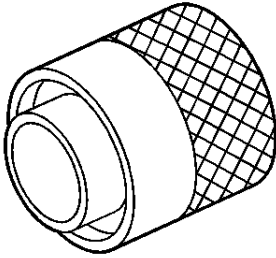

DT-47946
Bearing Installer

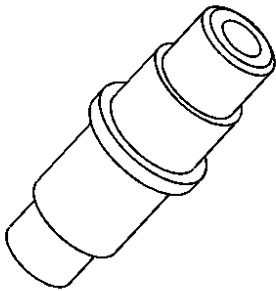

J 2619-O1
Slide Hammer



J 3289-20
Holding Fixture

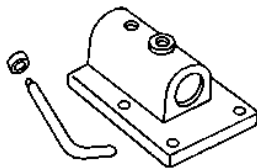

J 6125-1B
Slide Hammer with Adapter

2007 Hummer H3

2007 TRANSMISSION Transfer Case - BW 4493/4494 - H3

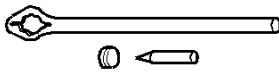
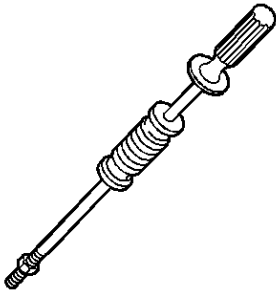

J 8614-01
Flange and Pulley Holding Tool

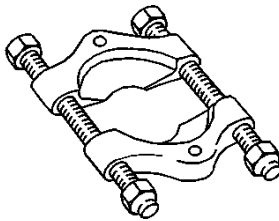

J 22912-B
Rear Pinion and Axle Bearing Remover

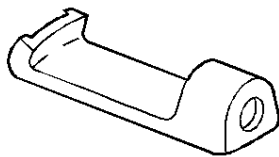

J 23129
Universal Seal Remover

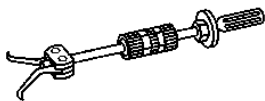

J 23907
Slide Hammer with Bearing Adapter

J 29369-1

2007 Hummer H3

2007 TRANSMISSION Transfer Case - BW 4493/4494 - H3

Bushing and Bearing Remover

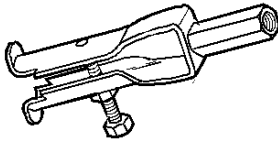

J 36850
Transjel Lubricant

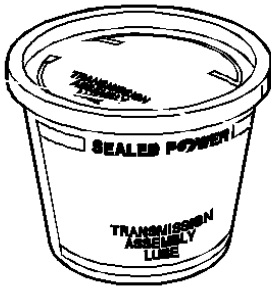

J 42176
Universal Driver Handle - Non-Threaded

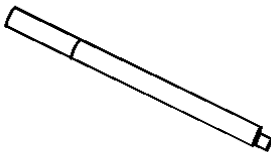

J 42738
Seal Installer

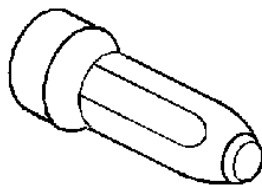

J 45278
Seal Remover

2007 Hummer H3

2007 TRANSMISSION Transfer Case - BW 4493/4494 - H3

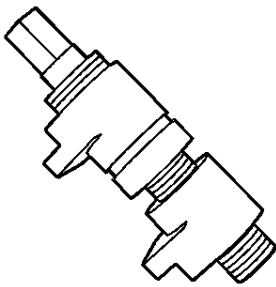
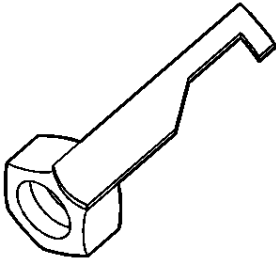

J 45358
Case Spreader

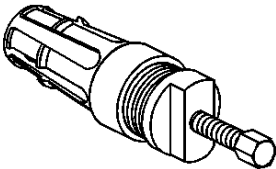

J 45380
Transfer Case Rear Bushing Remover and
Installer

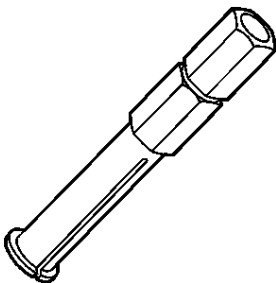

J 45548
Mainshaft Support Bushing/Bearing Remover

2007 Hummer H3

2007 TRANSMISSION Transfer Case - BW 4493/4494 - H3

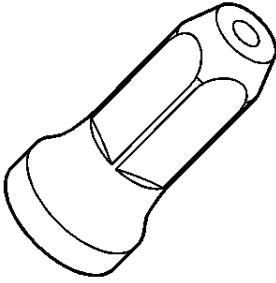

J 45756
Rear Output Shaft Seal Installer

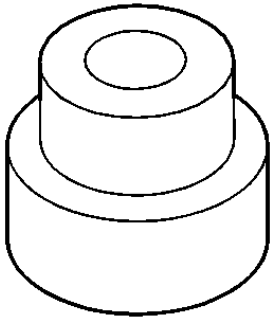

J 45757
Mainshaft Support Bushing and Bearing
Installer

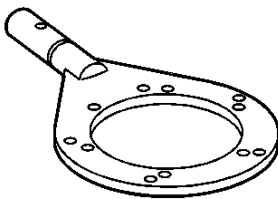

J 45759
Assembly Fixture